



## **ATTENTION!**

**For faultless operation, please read carefully this catalogue!**

**It was elaborated by ALTEST Company. Its copying, reproduction and reprinting without our consent is not welcomed!**

**The profiles presented in the catalogue are patented and ALTEST Company has the exclusive rights.**

**ALTEST Company reserves the right to modify the profiles and the presented sections at its own discretion. The system is equipped with full set of calculations made in accordance with the existing manufacturing requirements, presented in this catalogue.**

**In conclusion – use original ALTEST profiles in compliance with the peculiarities and the technical characteristics presented in this catalogue.**

## CONTENTS

1. INTRODUCTION	5
2. REVIEW OF PROFILES	6
3. PROFILES	9
4. GLASSPACKETS	23
5. SECTIONS	25
6. SECTIONAL DRAWINGS	29
7. SCHEMES	57
8. THREE DIMENSIONS DETAILS	67
9. PUTTING	86
10. THERMAL ANALYSIS	93
11. NOTES	94

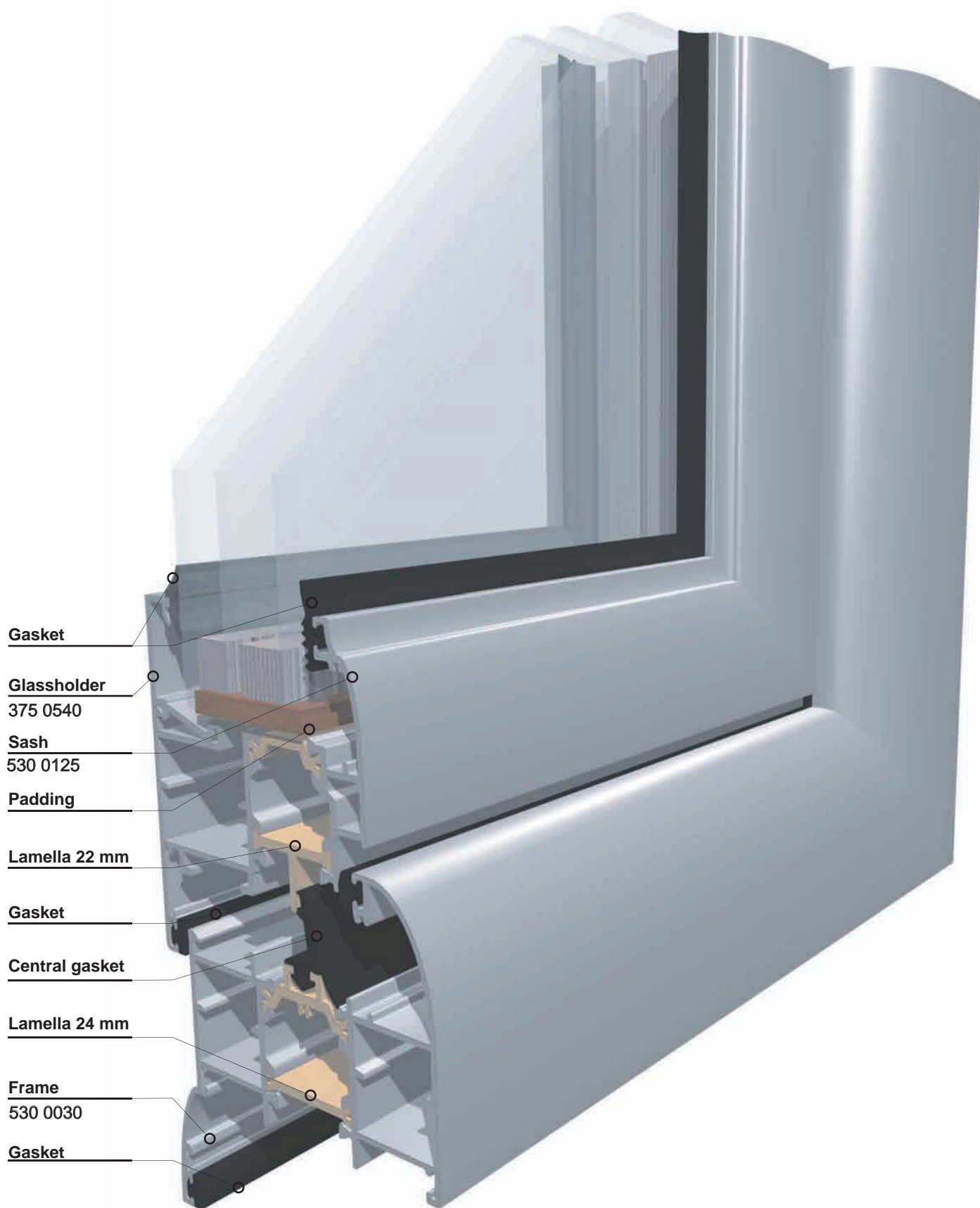

## INTRODUCTION

The "530 ESKIMOS" of company ALTEST is 53,0 mm aluminium series invented according to European standard and conformable to requirements and dimensions of the hardware – hinges, locks and etc.

It is a thermal break system with 24mm polyamide on the frame profile and 20-22mm for the sash.

The system consists of wide composition of profiles suitable for any kind of solutions. It is design to fulfil exterior and interior architectural suggestions whenever thermal break is required.

The system "530 ESKIMOS" is suitable for different version of opening and fixed systems.

The plentiful range of profiles, modern accessories and gaskets of EPDM guarantee the perfect draining and faultless performance in different situations. The series is suitable also for tilt and turn mechanism.

Versions of fixed, vertical and horizontal opening windows as well as fixed and opening sections doors are practicable.

The system "530 ESKIMOS" is based on work with 3 seal gaskets - central, outer and inner (the central gasket is specially design for the series). The dimensions of the profiles channel are conformable to the European Standard and in this way provide trouble-free use of hardware and connecting joints. It can be equipped with accessories from the companies: Monticelli, Giesse, Lavaal, Comunello, Roto, Savio, Fapim and etc.



The plentiful range basic profiles (frames) and glass holders, allows the usage of 20 to 29mm glazing. Of course variable design elaborations are possible, due to wide variety of frames, sashes and other auxiliary profiles. This is a modern aluminium system, satisfying the latest architectural tendencies of doors and windows productions where thermo-isolation is needed. These advantages allow the system to be integrated in all kind of weather conditions and different buildings.

The profiles can be painted in all range of RAL colors.





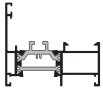
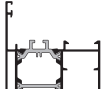
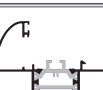
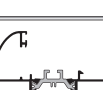
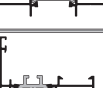
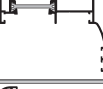
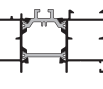
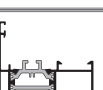
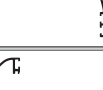

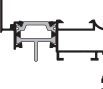
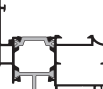

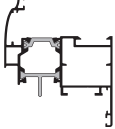
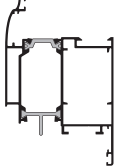
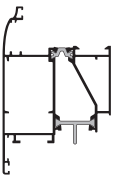
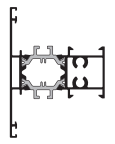
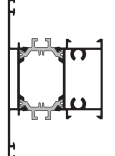
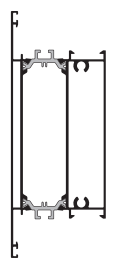
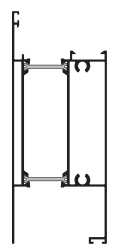
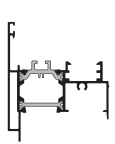
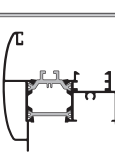
According to DIN 1725 T1 the aluminum used for production of aluminium profiles is AlMgSi0,5 F22.

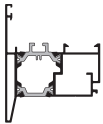
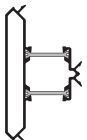
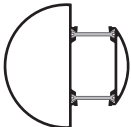
The technical and mechanical characteristics of the particular alloy are:

Elasticity module	:	70 000 Nmm <sup>-2</sup>
Coefficient of linear expansion	:	$\alpha = 2.34 \cdot 10^{-6} \text{ K}^{-1}$
Tensile strength	:	$R_m = 215 \text{ Nmm}^{-2}$
Relative density	:	$\gamma = 2.7 \text{ gr.cm}^{-3}$

SCHEMA	CODE	REL.WEIGHT, (gr/m)	INNERT MOMENTS Ix/Jy(cm)	DIMENSIONS X/Y(mm)
	530 0005	897	3,55/11,52	53,00/46,80
	530 0010	1094	7,81/14,31	53,00/57,30
	530 0015	1074	5,12/19,28	68,60/46,80
	530 0020	1292	10,39/23,78	68,60/57,30
	530 0025	1228	13,92/20,21	60,55/84,10
	530 0030	1426	16,74/31,58	76,15/84,10
	530 0035	1030	7,95/17,45	60,55/73,60
	530 0040	1207	9,73/27,09	76,15/73,60
	530 0105	995	5,30/16,46	60,50/62,40
	530 0110	1212	10,41/20,23	60,50/72,80
	530 0115	1538	30,02/26,28	60,50/93,90
	530 0120	1047	5,73/16,37	60,50/62,40

SCHEMA	CODE	REL.WEIGHT, (gr/m)	INNERT MOMENTS Ix/Jy(cm)	DIMENSIONS X/Y(mm)
	530 0125	1247	11,07/19,92	60,50/72,80
	530 0130	1571	31,29/25,95	60,50/93,90
	530 0135	1557	30,13/24,50	60,50/93,90
	530 0205	1276	9,27/15,76	53,00/73,00
	530 0210	1510	22,50/19,25	53,00/89,00
	530 0215	2224	120,52/29,94	53,00/138,00
	530 0220	2040	89,41/30,49	53,00/130,00
	530 0305	1114	7,78/14,91	56,30/61,00
	530 0310	1164	9,00/17,87	63,80/61,00

SCHEMA	CODE	REL.WEIGHT, (gr/m)	INNERT MOMENTS Ix/Jy(cm)	DIMENSIONS X/Y(mm)
	530 0315	1158	9,10/14,08	53,00/66,15
	530 0320	1090	15,10/8,45	42,80/77,00
	530 0325	1324	21,44/24,29	70,00/69,80
	530 5040	175	0,26/0,13	15,30/21,80
	375 0350	222	0,99/0,44	26,99/33,00
	375 0355	122	0,07/0,14	18,85/14,00
	375 0510	314	0,87/1,26	33,80/26,20
	375 0520	276	0,77/0,64	23,00/26,20
	375 0530	269	0,73/0,50	19,00/26,20
	375 0540	206	0,66/0,22	19,00/26,71
	375 0550	193	0,56/0,22	19,00/26,72

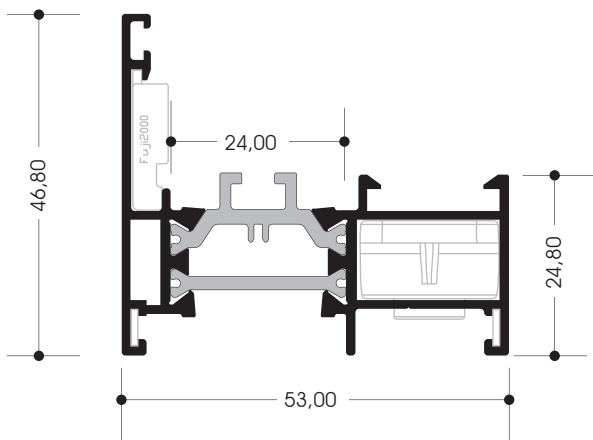

ACCESSORIES	
MECHANICAL PUTTING	0423
ALIGNMENT ANGLE	Fuji2000 5x1
CONGEST GASKET	OUTER CENTRAL
CAP	1601

FRAME		
CODE	530 0005	
REL.WEIGHT	(gr/m)	897
PERIMETER	(mm)	331
$I_x$	(cm <sup>4</sup> )	3,55
$J_y$	(cm <sup>4</sup> )	11,52

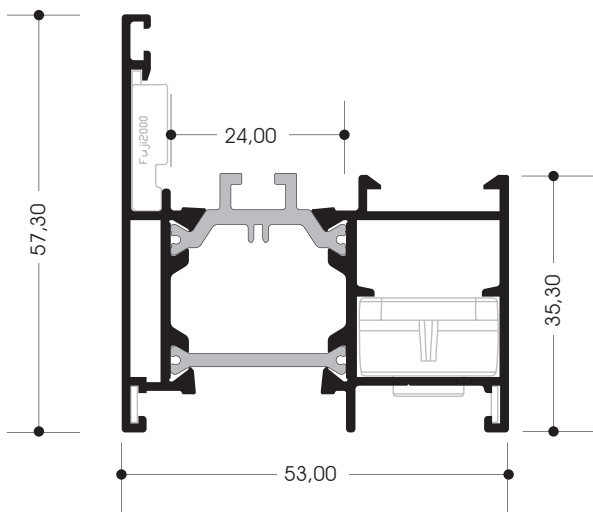

ACCESSORIES	
MECHANICAL PUTTING	0423
ALIGNMENT ANGLE	Fuji2000 5x1
CONGEST GASKET	OUTER CENTRAL
CAP	1601

FRAME		
CODE	530 0010	
REL.WEIGHT	(gr/m)	1094
PERIMETER	(mm)	352
$I_x$	(cm <sup>4</sup> )	7,81
$J_y$	(cm <sup>4</sup> )	14,31

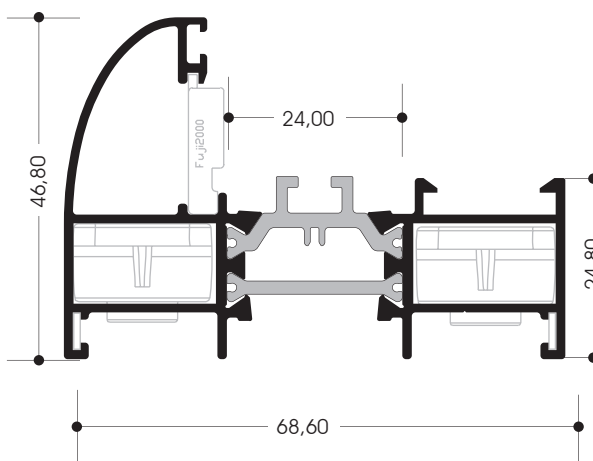

ACCESSORIES	
MECHANICAL PUTTING	0423
ALIGNMENT ANGLE	Fuji2000 5x1
CONGEST GASKET	OUTER CENTRAL
CAP	1601

FRAME		
CODE	530 0015	
REL.WEIGHT	(gr/m)	1074
PERIMETER	(mm)	405
$I_x$	(cm <sup>4</sup> )	5,12
$J_y$	(cm <sup>4</sup> )	19,28

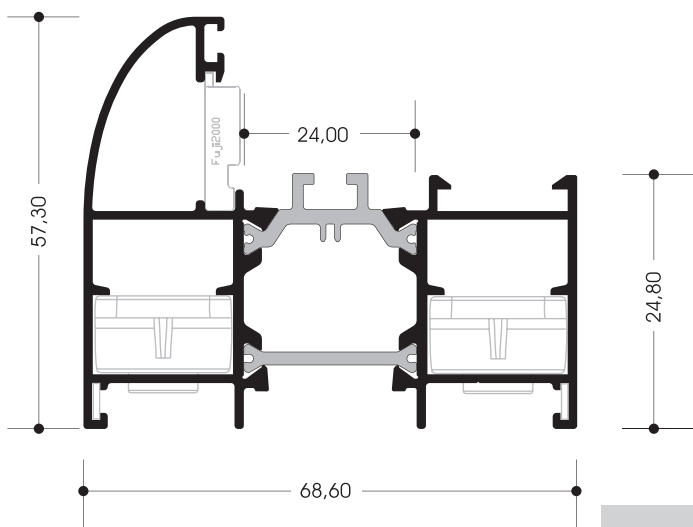

FRAME		
CODE	530 0020	
REL.WEIGHT	(gr/m)	1292
PERIMETER	(mm)	426
$I_x$	(cm <sup>4</sup> )	10,39
$J_y$	(cm <sup>4</sup> )	23,78

ACCESSORIES	
MECHANICAL PUTTING	0423
ALIGNMENT ANGLE	Fuji2000 5x1
CONGEST GASKET	OUTER CENTRAL
CAP	1601

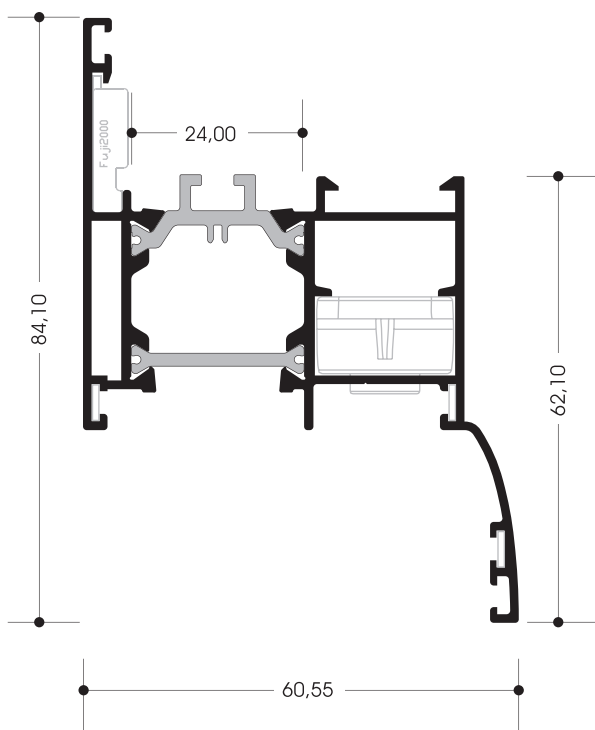

FRAME		
CODE	530 0025	
REL.WEIGHT	(gr/m)	1228
PERIMETER	(mm)	431
$I_x$	(cm <sup>4</sup> )	13,92
$J_y$	(cm <sup>4</sup> )	20,21

ACCESSORIES	
MECHANICAL PUTTING	0423
ALIGNMENT ANGLE	Fuji2000 5x1
CONGEST GASKET	OUTER CENTRAL
CAP	1601

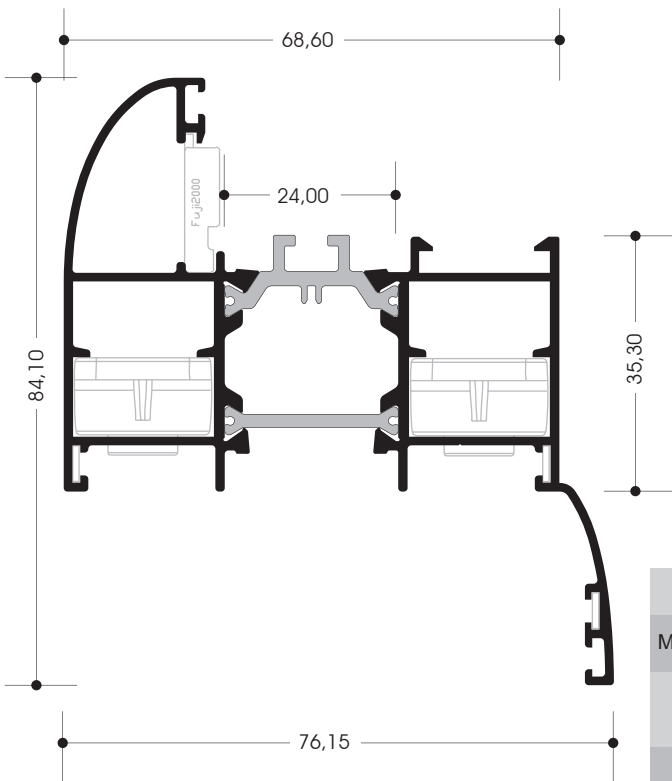

ACCESSORIES	
MECHANICAL PUTTING	0423
ALIGNMENT ANGLE	Fuji2000 5x1
CONGEST GASKET	OUTER CENTRAL
CAP	1601

FRAME		
CODE	530 0030	
REL.WEIGHT	(gr/m)	1426
PERIMETER	(mm)	505
I <sub>x</sub>	(cm <sup>4</sup> )	16,74
J <sub>y</sub>	(cm <sup>4</sup> )	31,58

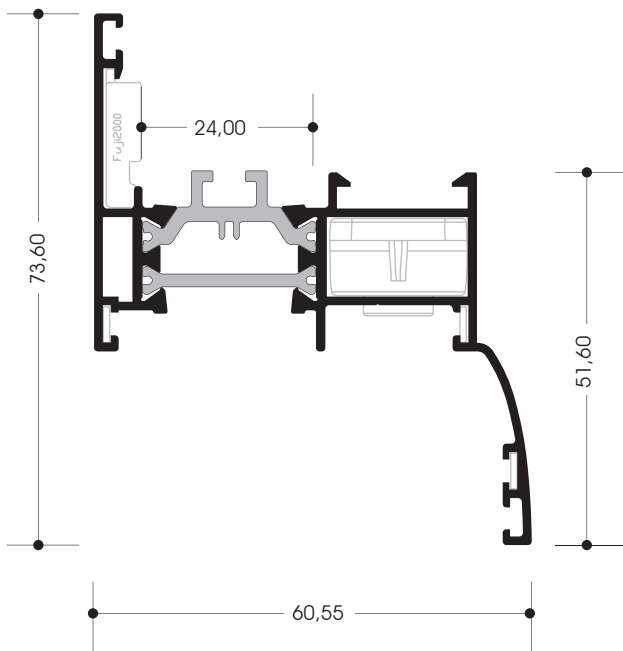

ACCESSORIES	
MECHANICAL PUTTING	0423
ALIGNMENT ANGLE	Fuji2000 5x1
CONGEST GASKET	OUTER CENTRAL
CAP	1601

FRAME		
CODE	530 0035	
REL.WEIGHT	(gr/m)	1030
PERIMETER	(mm)	410
I <sub>x</sub>	(cm <sup>4</sup> )	7,95
J <sub>y</sub>	(cm <sup>4</sup> )	17,45

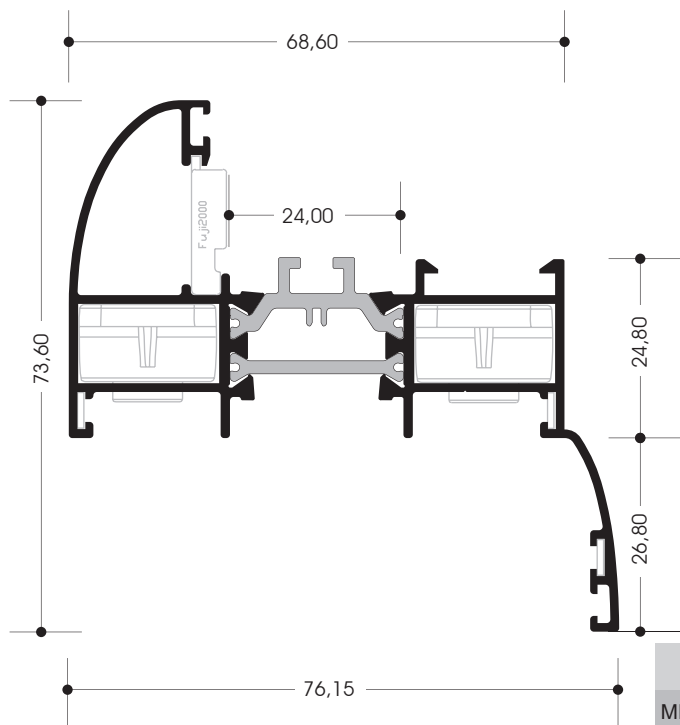

FRAME		
CODE	530 0040	
REL.WEIGHT	(gr/m)	1207
PERIMETER	(mm)	484
$I_x$	(cm <sup>4</sup> )	9,73
$J_y$	(cm <sup>4</sup> )	27,09

ACCESSORIES	
MECHANICAL PUTTING	0423
ALIGNMENT ANGLE	Fuji2000 5x1
CONGEST GASKET	OUTER CENTRAL
CAP	1601

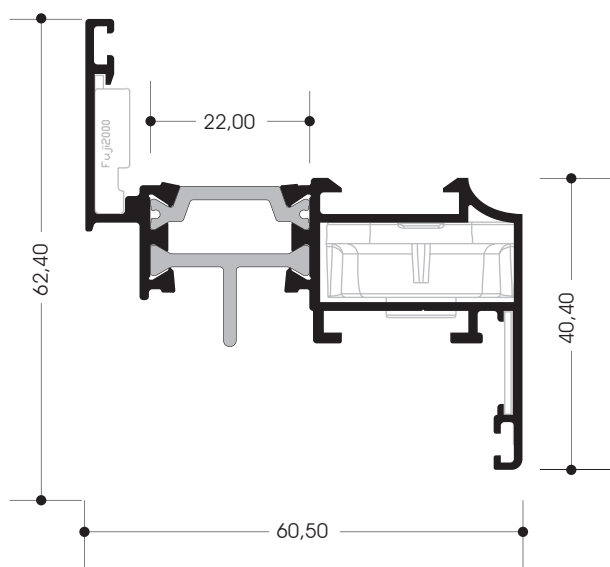

SASH		
CODE	530 0105	
REL.WEIGHT	(gr/m)	995
PERIMETER	(mm)	380
$I_x$	(cm <sup>4</sup> )	5,30
$J_y$	(cm <sup>4</sup> )	16,46

ACCESSORIES	
MECHANICAL PUTTING	0365
ALIGNMENT ANGLE	Fuji2000 14,1x1,2
CONGEST GASKET	OUTER CENTRAL
CAP	1601

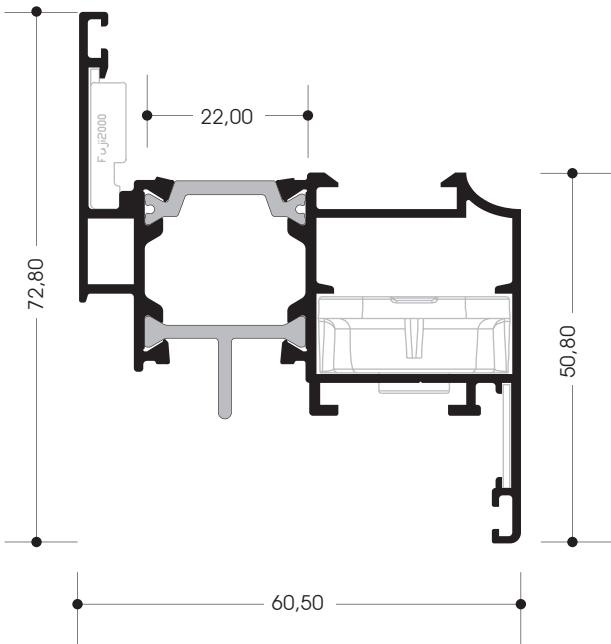

ACCESSORIES	
MECHANICAL PUTTING	0365
ALIGNMENT ANGLE	Fuji2000 14,1x1,2
CONGEST GASKET	OUTER CENTRAL
CAP	1601

SASH		
CODE	530 0110	
REL.WEIGHT	(gr/m)	1212
PERIMETER	(mm)	401
$I_x$	(cm <sup>4</sup> )	10,41
$J_y$	(cm <sup>4</sup> )	20,23

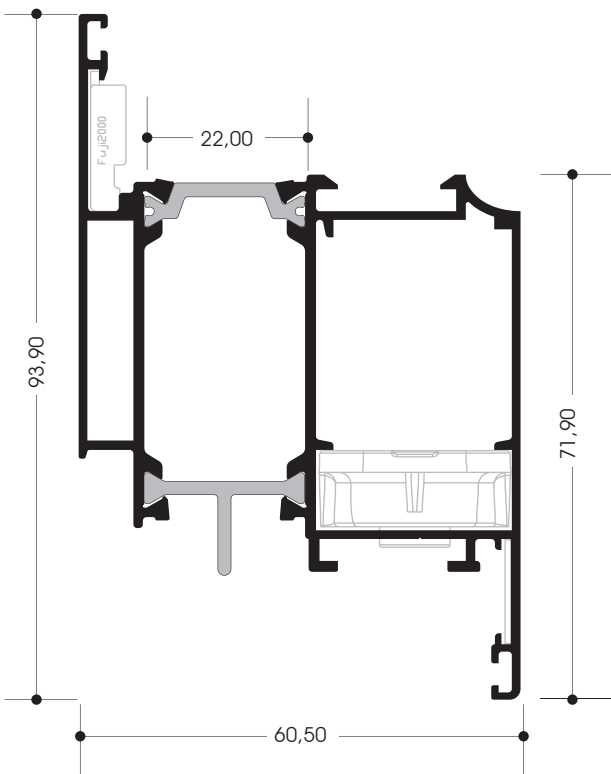

ACCESSORIES	
MECHANICAL PUTTING	0365
ALIGNMENT ANGLE	Fuji2000 14,1x1,2
CONGEST GASKET	OUTER CENTRAL
CAP	1601

SASH		
CODE	530 0115	
REL.WEIGHT	(gr/m)	1538
PERIMETER	(mm)	443
$I_x$	(cm <sup>4</sup> )	30,02
$J_y$	(cm <sup>4</sup> )	26,28

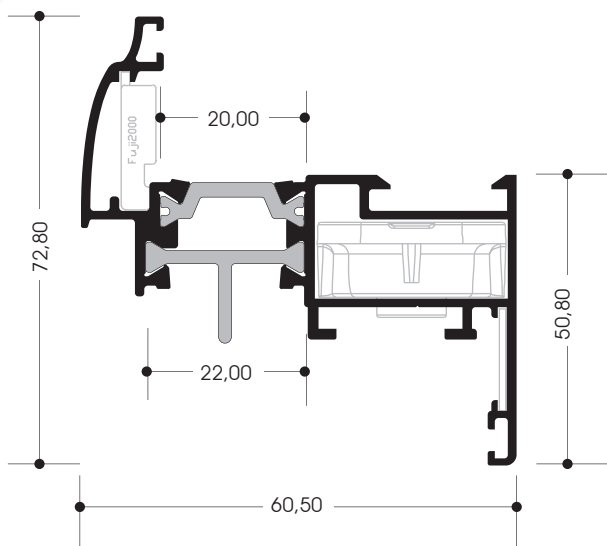

ACCESSORIES	
MECHANICAL PUTTING	0365
ALIGNMENT ANGLE	Fuji2000 14,1x1,2
CONGEST GASKET	OUTER CENTRAL
CAP	1601

SASH		
CODE	530 0120	
REL.WEIGHT	(gr/m)	1247
PERIMETER	(mm)	394
$I_x$	(cm <sup>4</sup> )	5,73
$J_y$	(cm <sup>4</sup> )	16,37

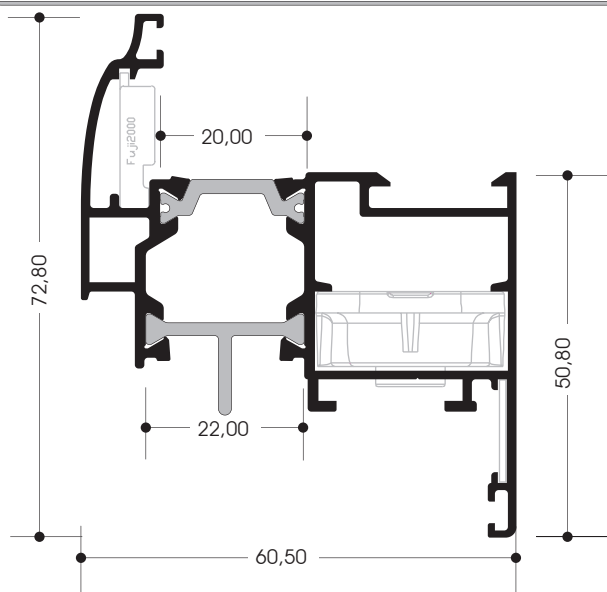

ACCESSORIES	
MECHANICAL PUTTING	0365
ALIGNMENT ANGLE	Fuji2000 14,1x1,2
CONGEST GASKET	OUTER CENTRAL
CAP	1601

SASH		
CODE	530 0125	
REL.WEIGHT	(gr/m)	1247
PERIMETER	(mm)	414
$I_x$	(cm <sup>4</sup> )	11,07
$J_y$	(cm <sup>4</sup> )	19,92

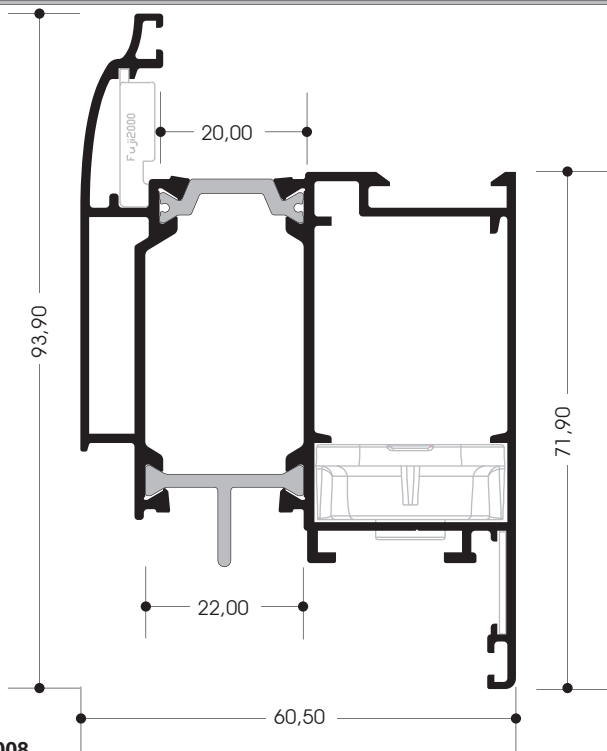

ACCESSORIES	
MECHANICAL PUTTING	0365
ALIGNMENT ANGLE	Fuji2000 14,1x1,2
CONGEST GASKET	OUTER CENTRAL
CAP	1601

SASH		
CODE	530 0130	
REL.WEIGHT	(gr/m)	1571
PERIMETER	(mm)	457
$I_x$	(cm <sup>4</sup> )	31,29
$J_y$	(cm <sup>4</sup> )	25,95

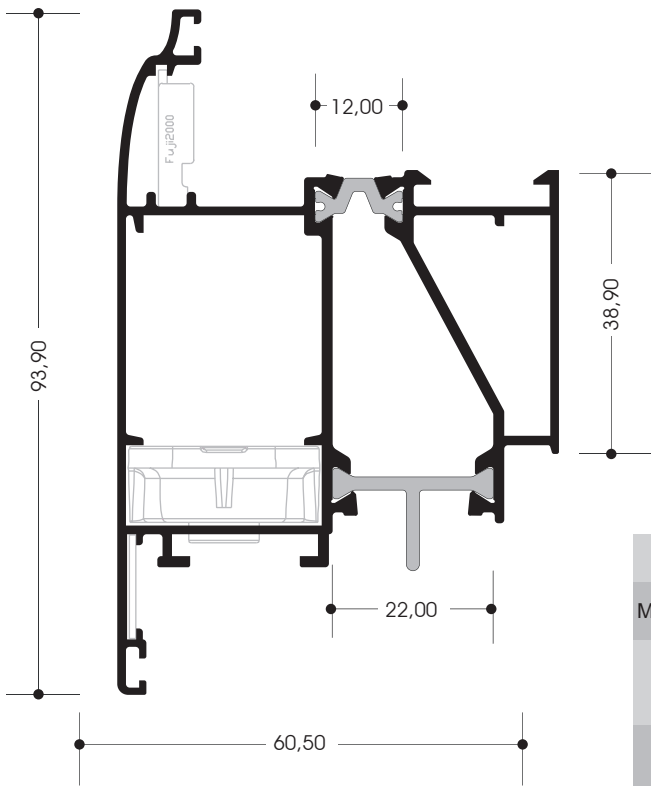

ACCESSORIES	
MECHANICAL PUTTING	0365
ALIGNMENT ANGLE	Fuji2000 14,1x1,2
CONGEST GASKET	OUTER CENTRAL
CAP	1601

FRAME		
CODE	530 0135	
REL.WEIGHT	(gr/m)	1557
PERIMETER	(mm)	457
$I_x$	(cm <sup>4</sup> )	30,13
$J_y$	(cm <sup>4</sup> )	24,50

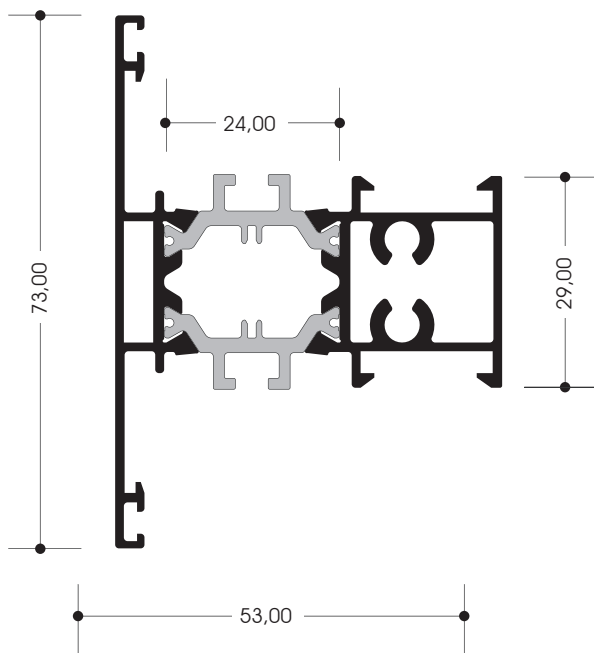

ACCESSORIES	
SCREW	4 pcs
CONGEST GASKET	OUTER CENTRAL OUTER GLASS
CAP	1601

MULLION		
CODE	530 0205	
REL.WEIGHT	(gr/m)	1276
PERIMETER	(mm)	417
$I_x$	(cm <sup>4</sup> )	9,27
$J_y$	(cm <sup>4</sup> )	15,76

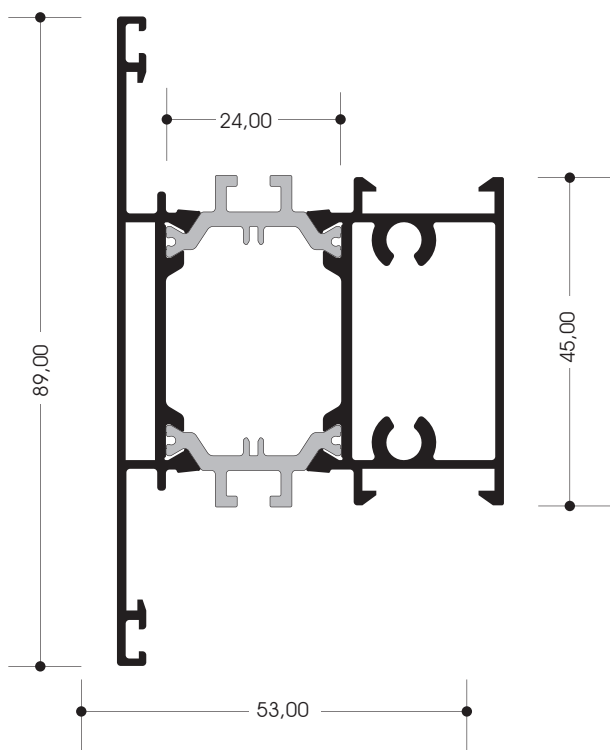

MULLION		
CODE	530 0210	
REL.WEIGHT	(gr/m)	1510
PERIMETER	(mm)	449
$I_x$	(cm <sup>4</sup> )	22,50
$J_y$	(cm <sup>4</sup> )	19,25

ACCESSORIES	
SCREW	4 pcs
CONGEST GASKET	OUTER
	CENTRAL
	OUTER GLASS
CAP	1601

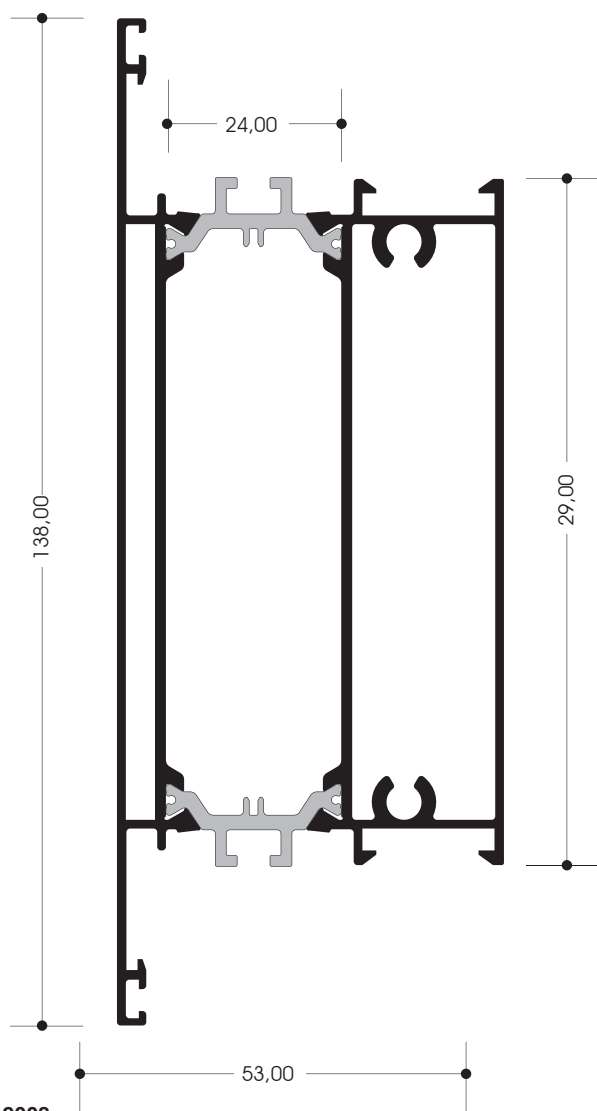

MULLION		
CODE	530 0215	
REL.WEIGHT	(gr/m)	2224
PERIMETER	(mm)	546
$I_x$	(cm <sup>4</sup> )	120,52
$J_y$	(cm <sup>4</sup> )	29,94

ACCESSORIES	
SCREW	4 pcs
CONGEST GASKET	OUTER
	CENTRAL
	OUTER GLASS
CAP	1601

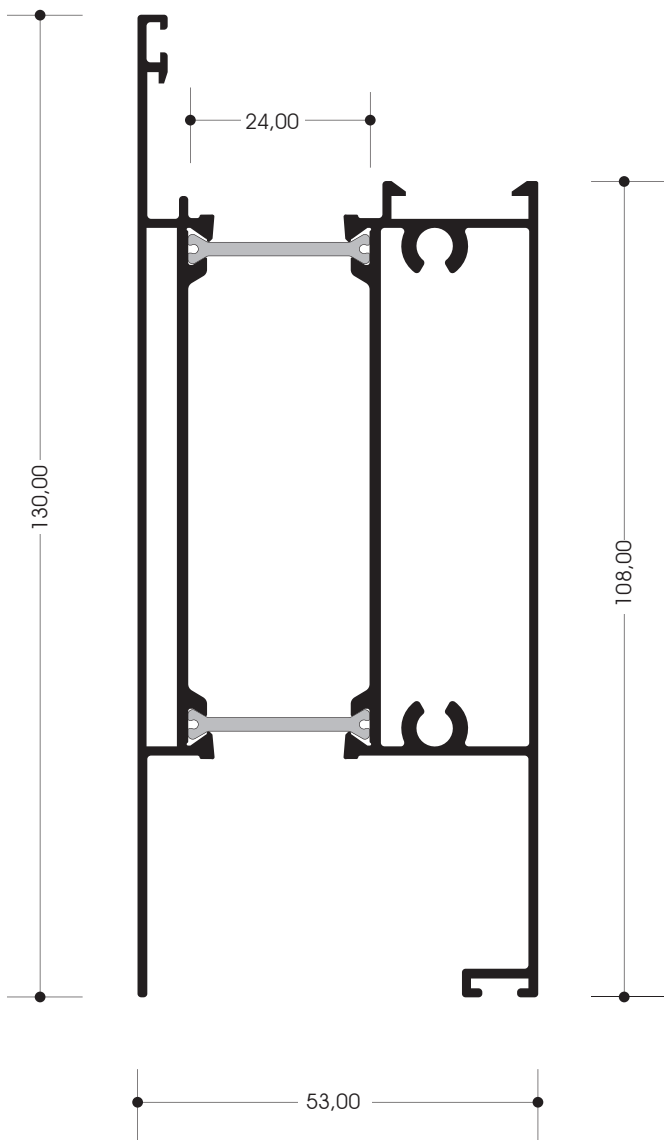

#### BOARD FOR DOOR

CODE	530 0220	
REL.WEIGHT	(gr/m)	2040
PERIMETER	(mm)	522
$I_x$	(cm <sup>4</sup> )	89,41
$J_y$	(cm <sup>4</sup> )	30,49

#### ACCESSORIES

SCREW	4 pcs
CONGEST GASKET	OUTER GLASS
CAP	1601
BRUSH	8 (mm)
CONGEST SYSTEM	1 pcs

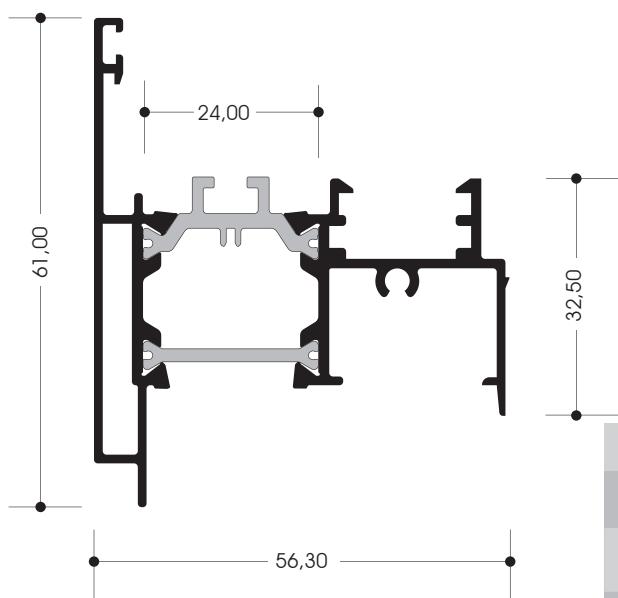

ACCESSORIES	
SCREW	2 pcs
CONGEST GASKET	OUTER CENTRAL
CAP	1601

OVERHUNG		
CODE	530 0305	
REL.WEIGHT	(gr/m)	1114
PERIMETER	(mm)	417
$I_x$	(cm <sup>4</sup> )	7,78
$J_y$	(cm <sup>4</sup> )	14,91

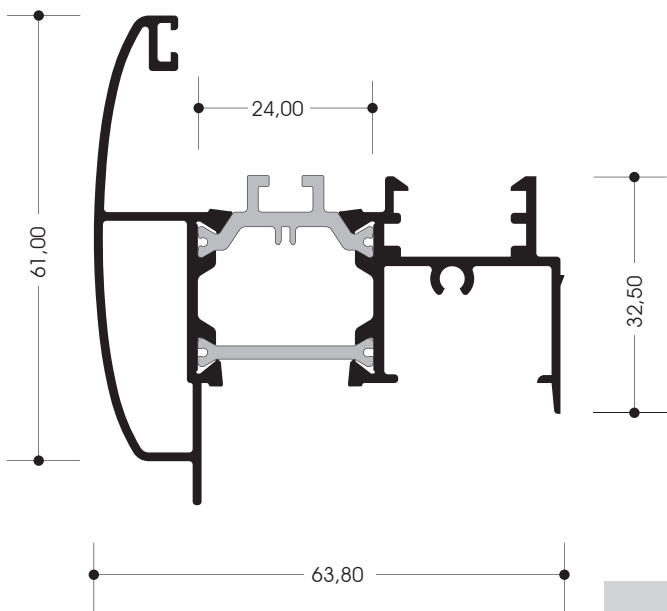

ACCESSORIES	
SCREW	2 pcs
CONGEST GASKET	OUTER CENTRAL
CAP	1601

OVERHUNG		
CODE	530 0310	
REL.WEIGHT	(gr/m)	1164
PERIMETER	(mm)	436
$I_x$	(cm <sup>4</sup> )	9,00
$J_y$	(cm <sup>4</sup> )	17,87

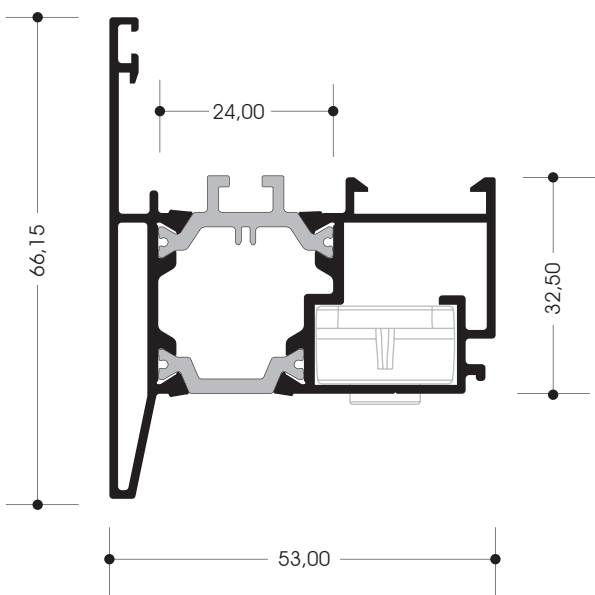

#### PROF. OPPEING OUT

CODE	530 0315	
REL.WEIGHT	(gr/m)	1158
PERIMETER	(mm)	335
$I_x$	(cm <sup>4</sup> )	9,10
$J_y$	(cm <sup>4</sup> )	14,08

#### ACCESSORIES

MECHANICAL PUTTING	0423
CONGEST GASKET	OUTER CENTRAL
CAP	1601

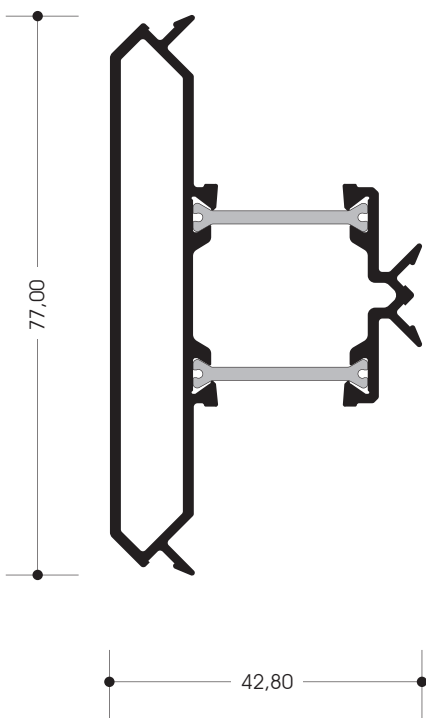

#### COLUMN FOR ANGLE 90

CODE	375 0320	
REL.WEIGHT	(gr/m)	1090
PERIMETER	(mm)	278
$I_x$	(cm <sup>4</sup> )	15,10
$J_y$	(cm <sup>4</sup> )	8,45

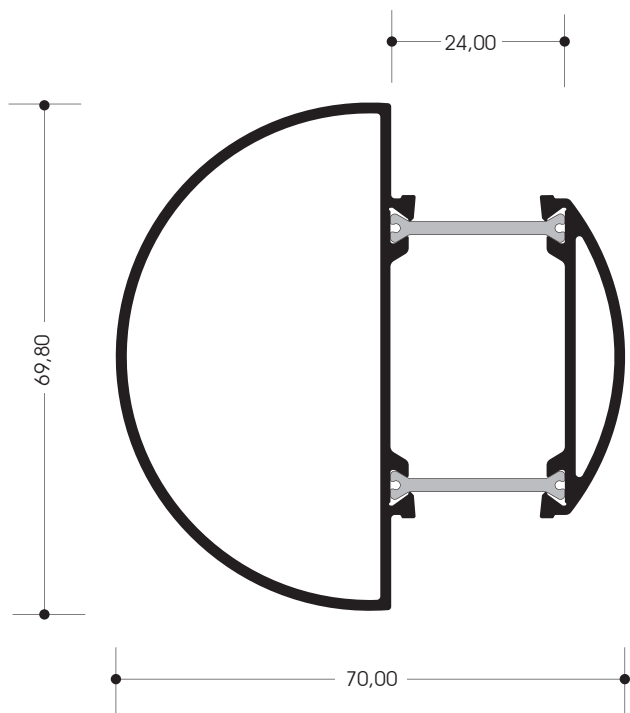

PIPE		
CODE	530 0325	
REL.WEIGHT	(gr/m)	1324
PERIMETER	(mm)	256
$I_x$	(cm <sup>4</sup> )	21,44
$J_y$	(cm <sup>4</sup> )	24,29

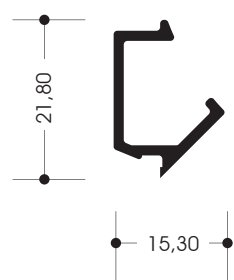

ADDITION FOR PIPE		
CODE	530 5040	
REL.WEIGHT	(gr/m)	175
PERIMETER	(mm)	90
$I_x$	(cm <sup>4</sup> )	0,26
$J_y$	(cm <sup>4</sup> )	0,13

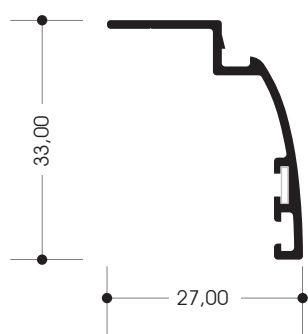

DECORATING PROFILE		
CODE	375 0350	
REL.WEIGHT	(gr/m)	222
PERIMETER	(mm)	133
$I_x$	(cm <sup>4</sup> )	0,99
$J_y$	(cm <sup>4</sup> )	0,44

#### ACCESSORIES

CONGEST GASKET	INNER
ALIGNMENT ANGLE	5x1

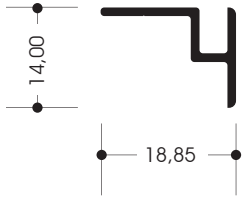

DECORATING PROFILE		
CODE	375 0355	
REL.WEIGHT	(gr/m)	122
PERIMETER	(mm)	76
$I_x$	(cm <sup>4</sup> )	0,07
$J_y$	(cm <sup>4</sup> )	0,14

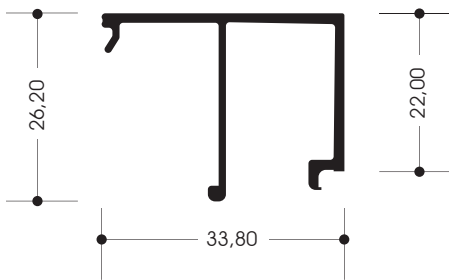

GLASSHOLDER		
CODE	375 0510	
REL.WEIGHT	(gr/m)	314
PERIMETER	(mm)	183
$I_x$	(cm <sup>4</sup> )	0,87
$J_y$	(cm <sup>4</sup> )	1,26

#### ACCESSORIES

CONGEST GASKET

GLASS INNER

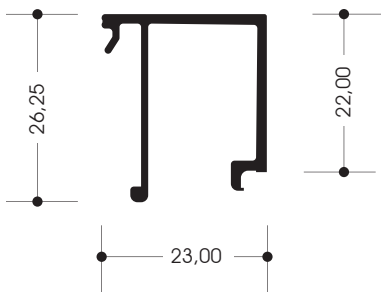

GLASSHOLDER		
CODE	375 0520	
REL.WEIGHT	(gr/m)	276
PERIMETER	(mm)	161
$I_x$	(cm <sup>4</sup> )	0,77
$J_y$	(cm <sup>4</sup> )	0,64

#### ACCESSORIES

CONGEST GASKET

GLASS INNER

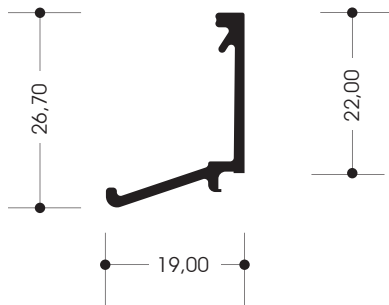

#### GLASSHOLDER

CODE	375 0550	
REL.WEIGHT	(gr/m)	193
PERIMETER	(mm)	96
$I_x$	(cm <sup>4</sup> )	0,56
$J_y$	(cm <sup>4</sup> )	0,22

#### ACCESSORIES

CONGEST GASKET      GLASS INNER

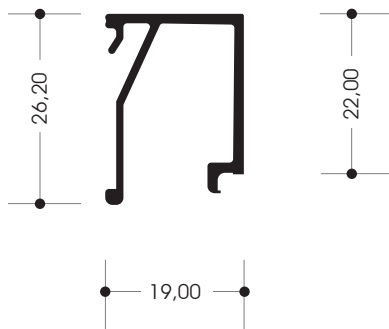

#### GLASSHOLDER

CODE	375 0530	
REL.WEIGHT	(gr/m)	269
PERIMETER	(mm)	155
$I_x$	(cm <sup>4</sup> )	0,73
$J_y$	(cm <sup>4</sup> )	0,50

#### ACCESSORIES

CONGEST GASKET      GLASS INNER

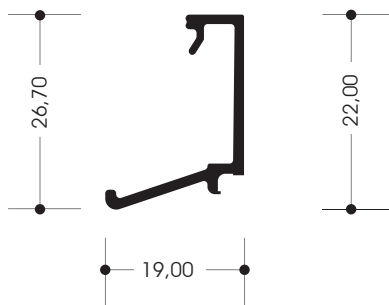

#### GLASSHOLDER

CODE	375 0540	
REL.WEIGHT	(gr/m)	206
PERIMETER	(mm)	110
$I_x$	(cm <sup>4</sup> )	0,66
$J_y$	(cm <sup>4</sup> )	0,22

#### ACCESSORIES

CONGEST GASKET      GLASS INNER

## GLASSPACKETS

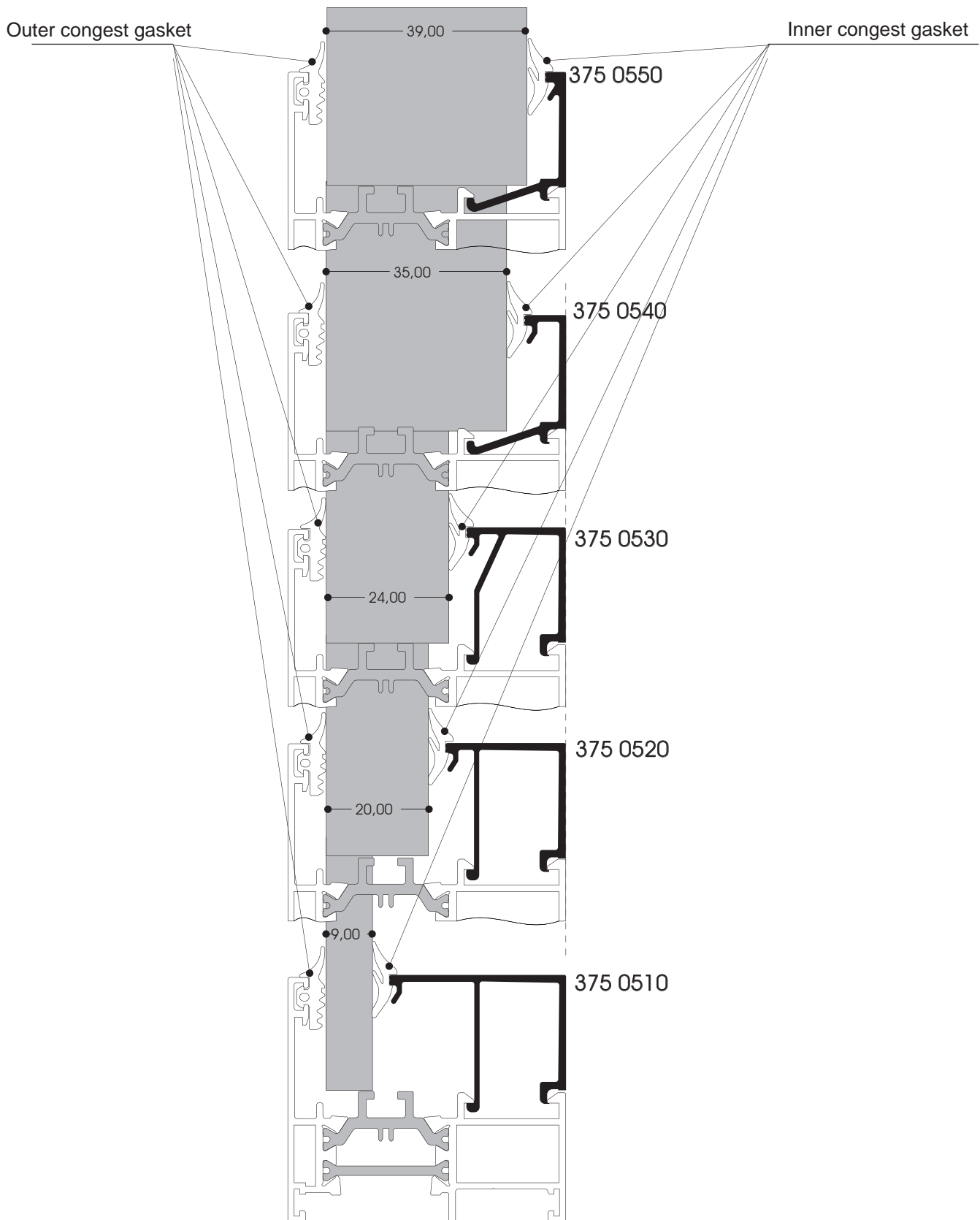



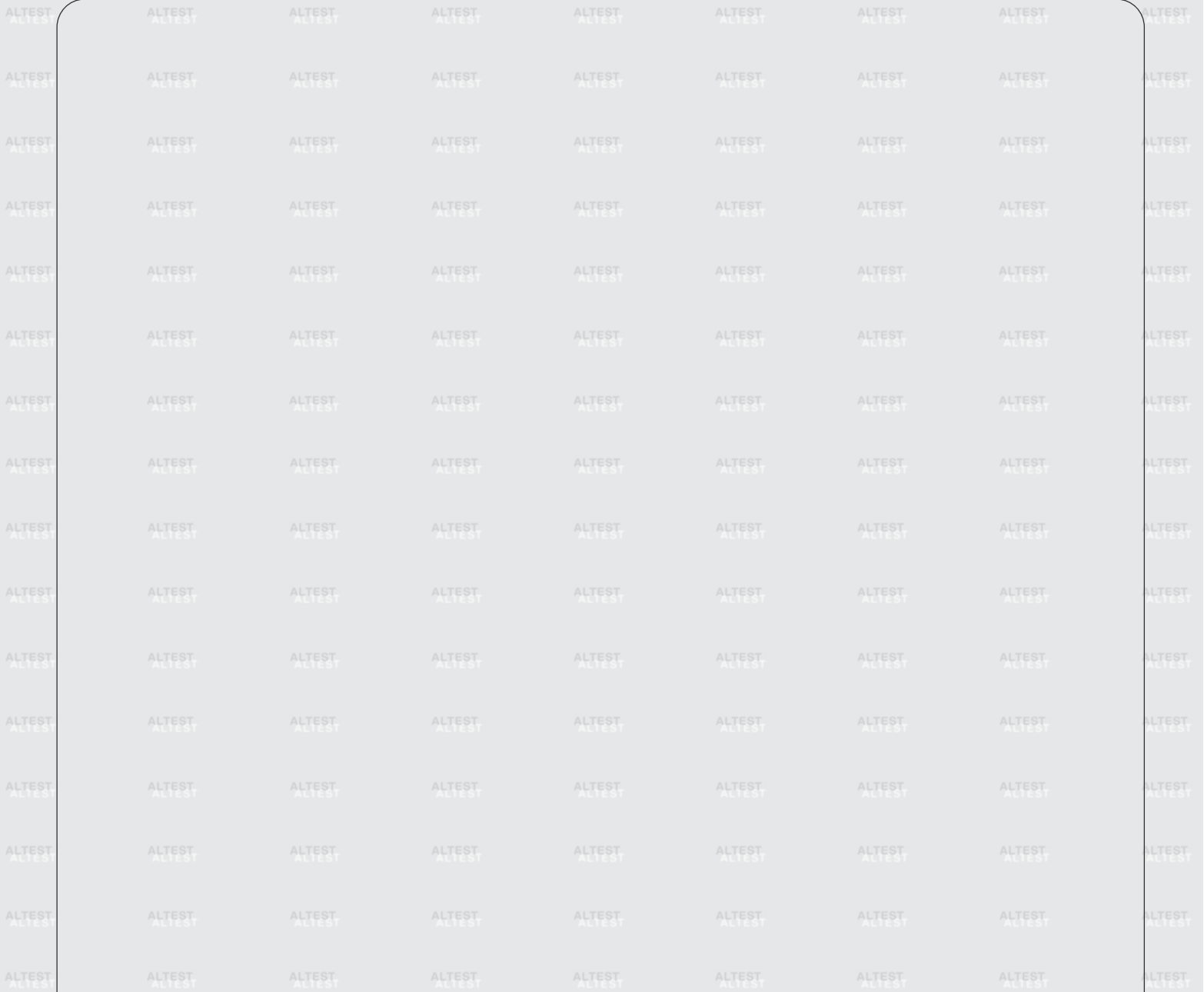

# Sections



## ASPECT SECTIONS

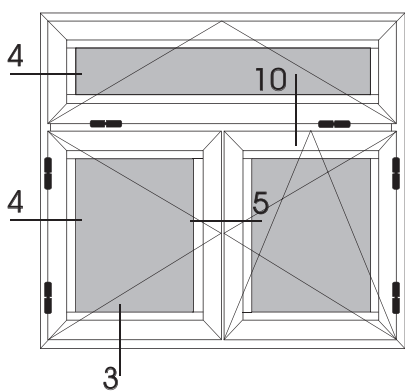
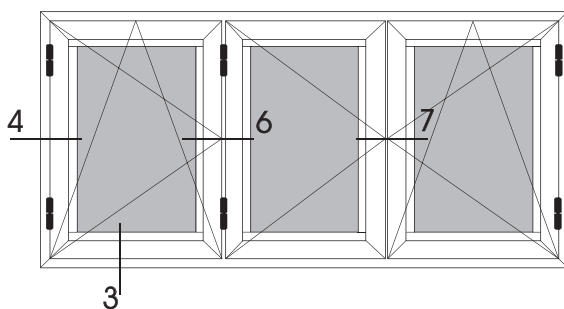
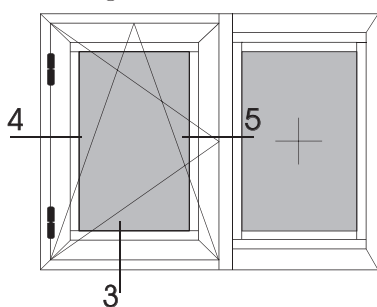
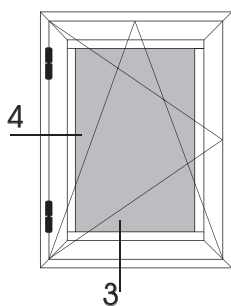
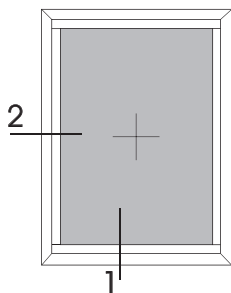

## ASPECT SECTIONS

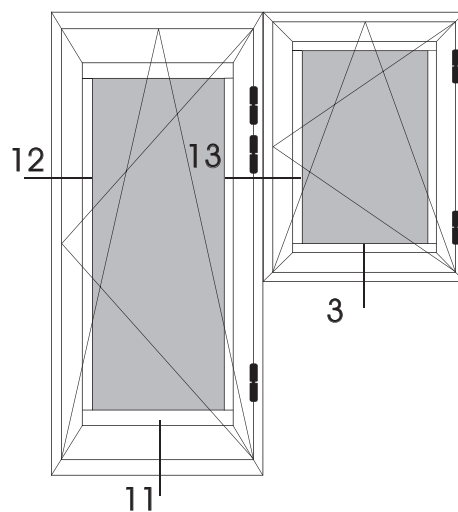
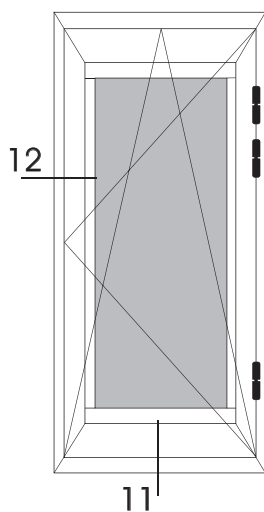
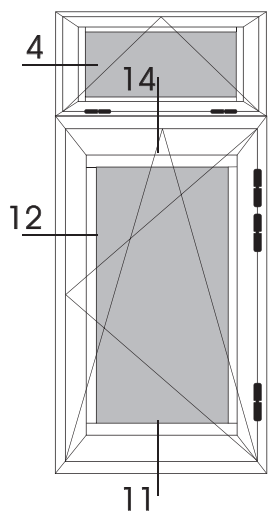
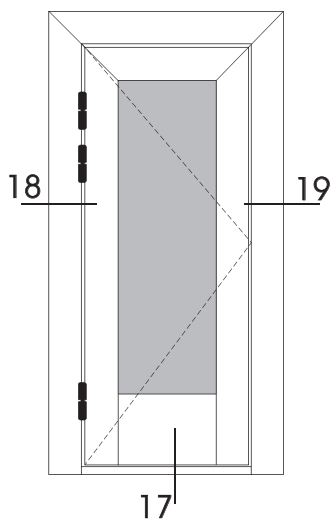
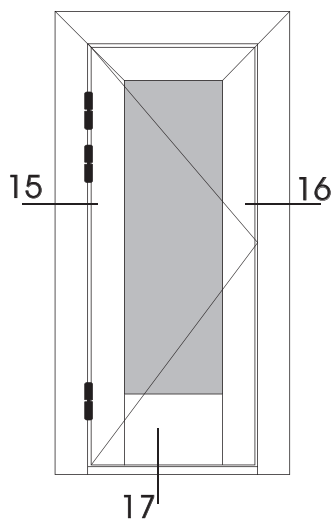
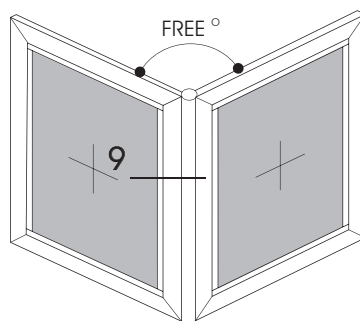
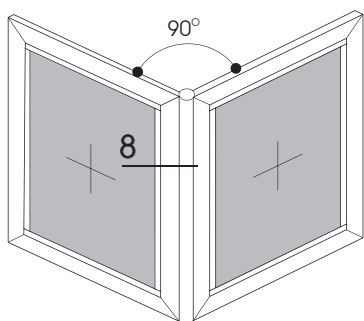

## ASPECT SECTIONS

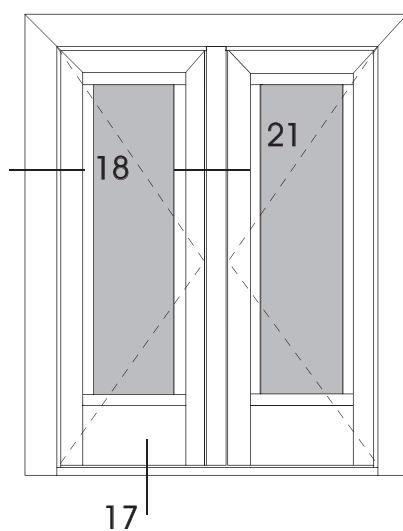
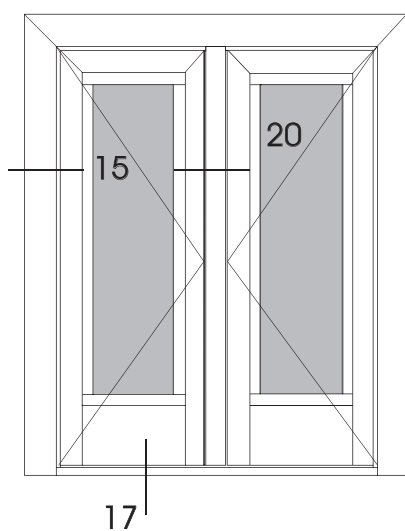
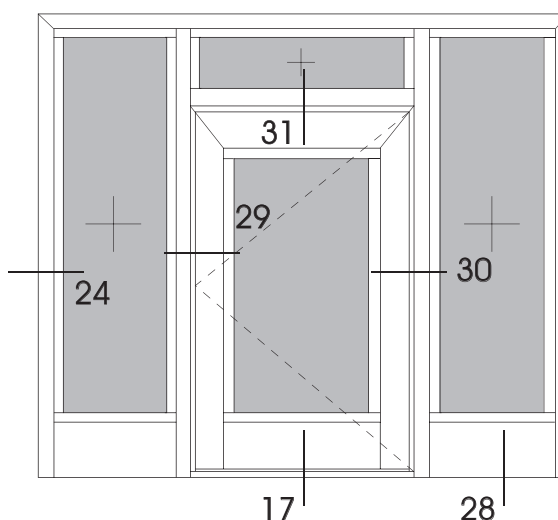
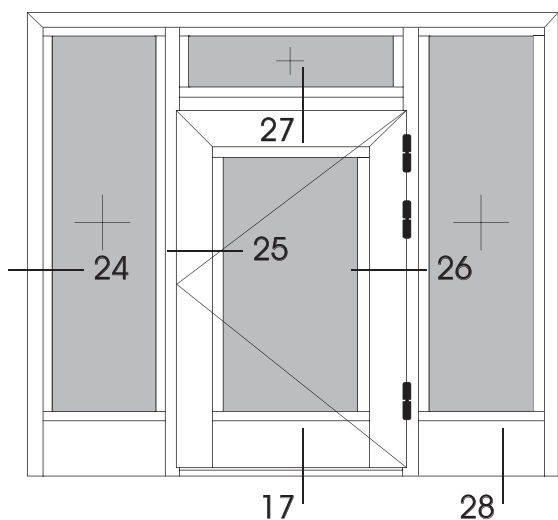
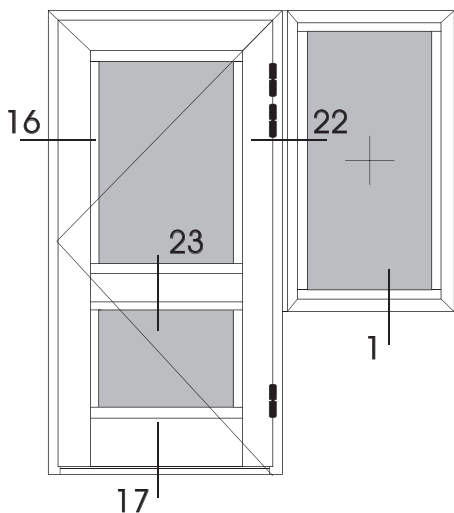

## SECTIONS

2.

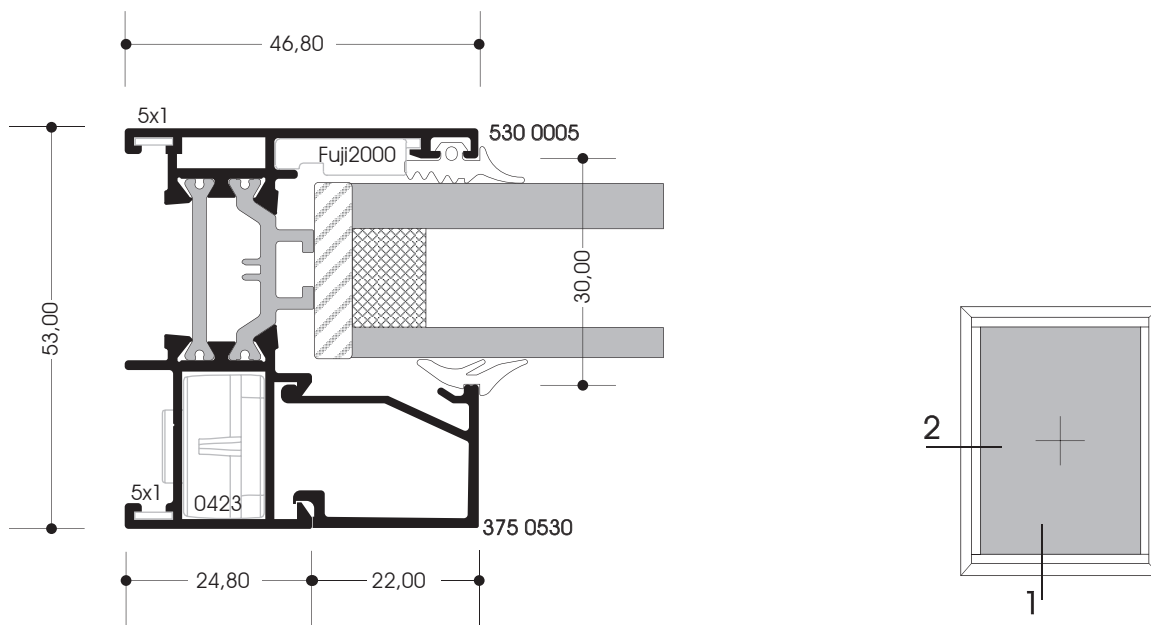

1.

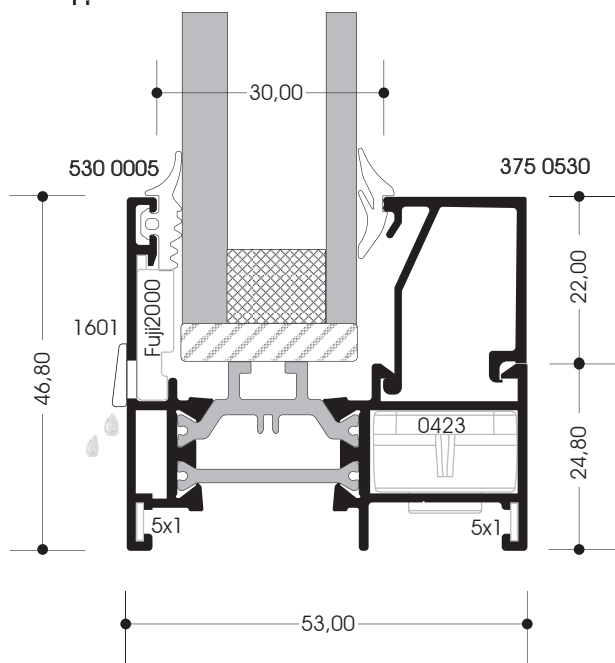

## SECTIONS

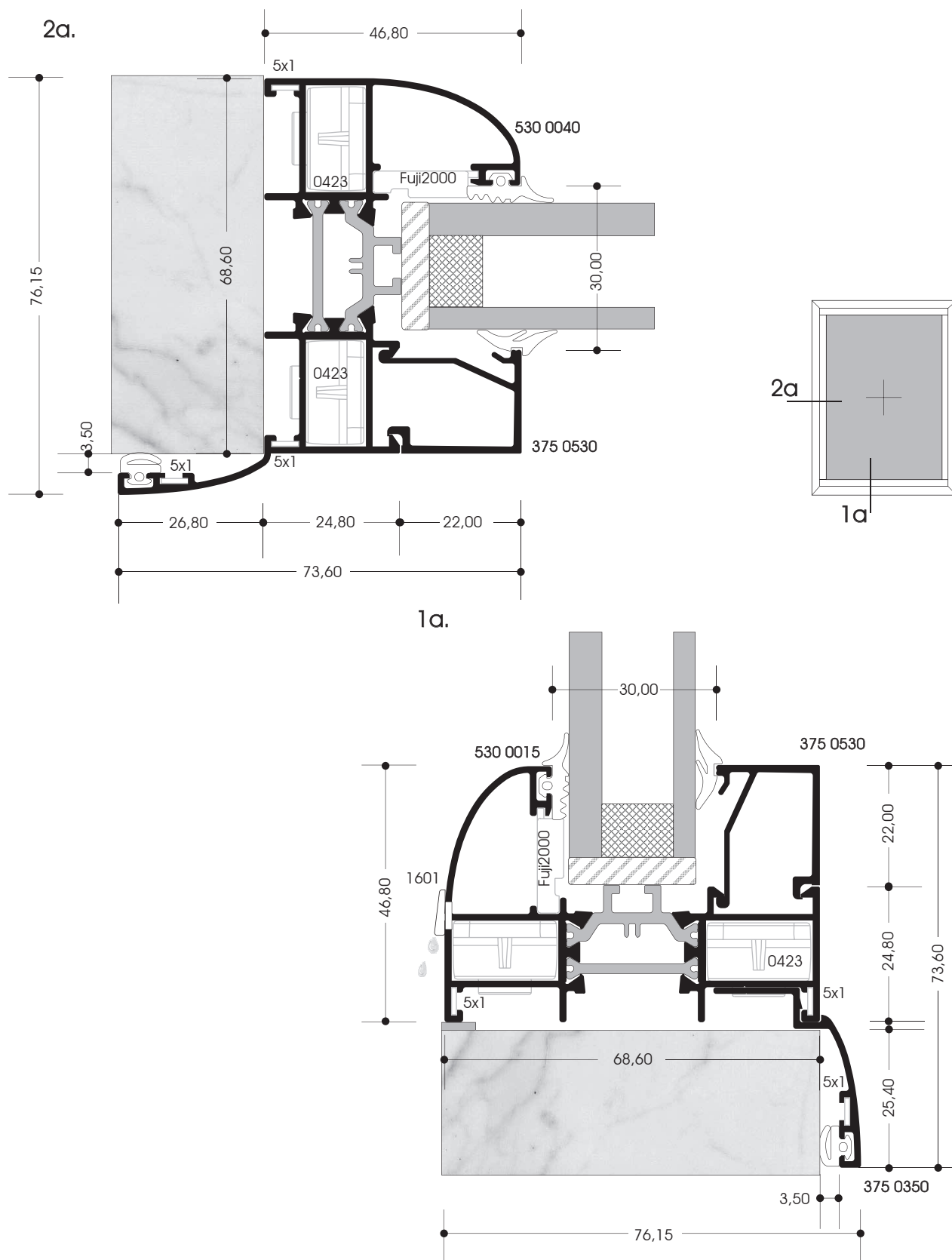

## SECTIONS

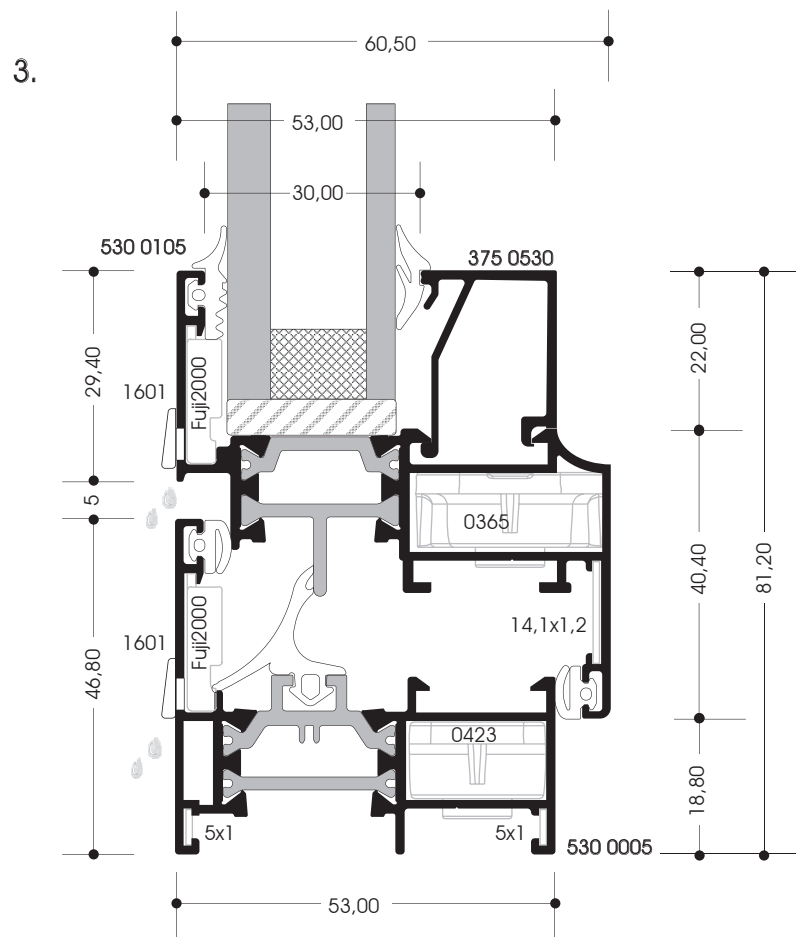
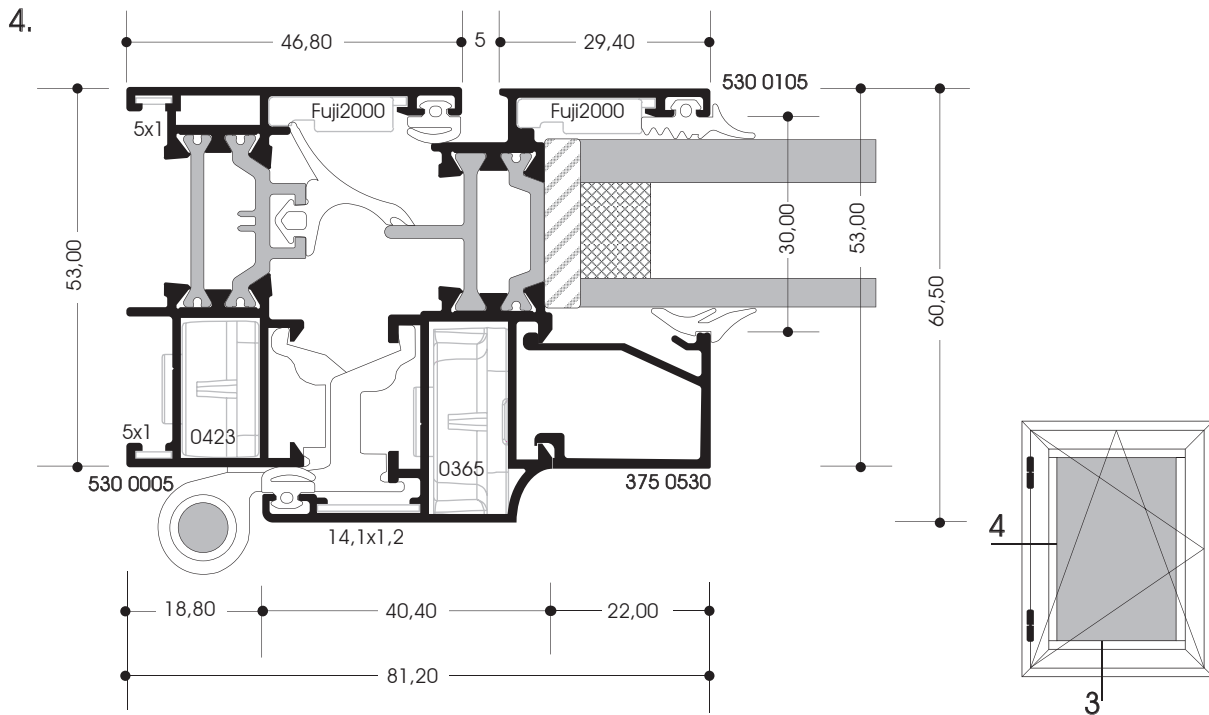

## SECTIONS

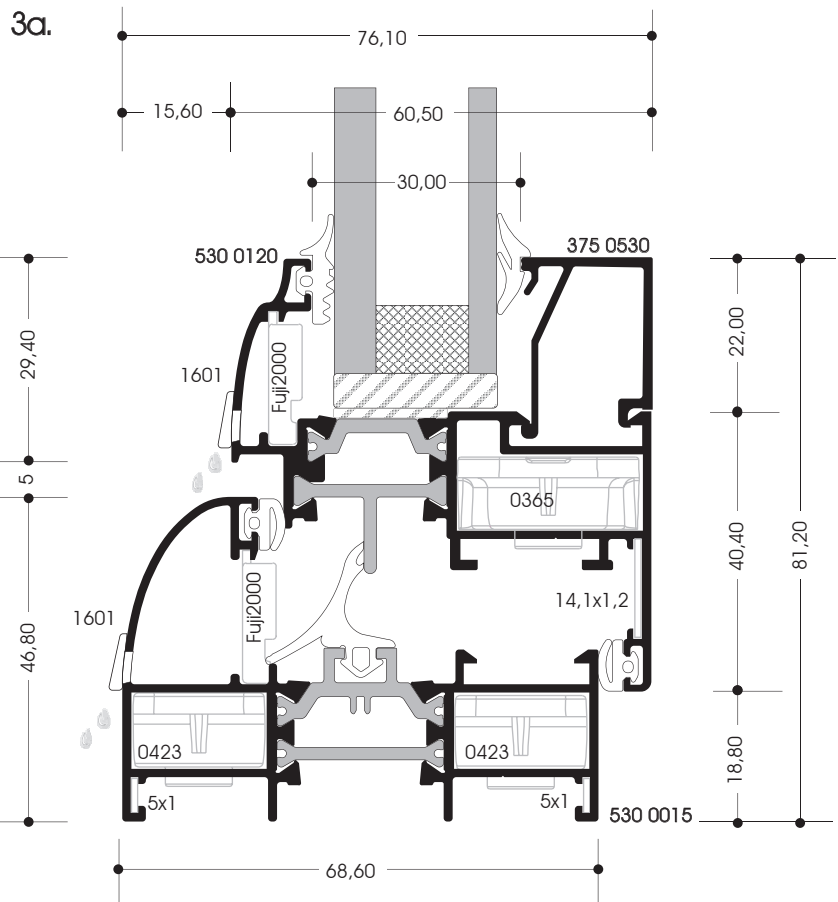
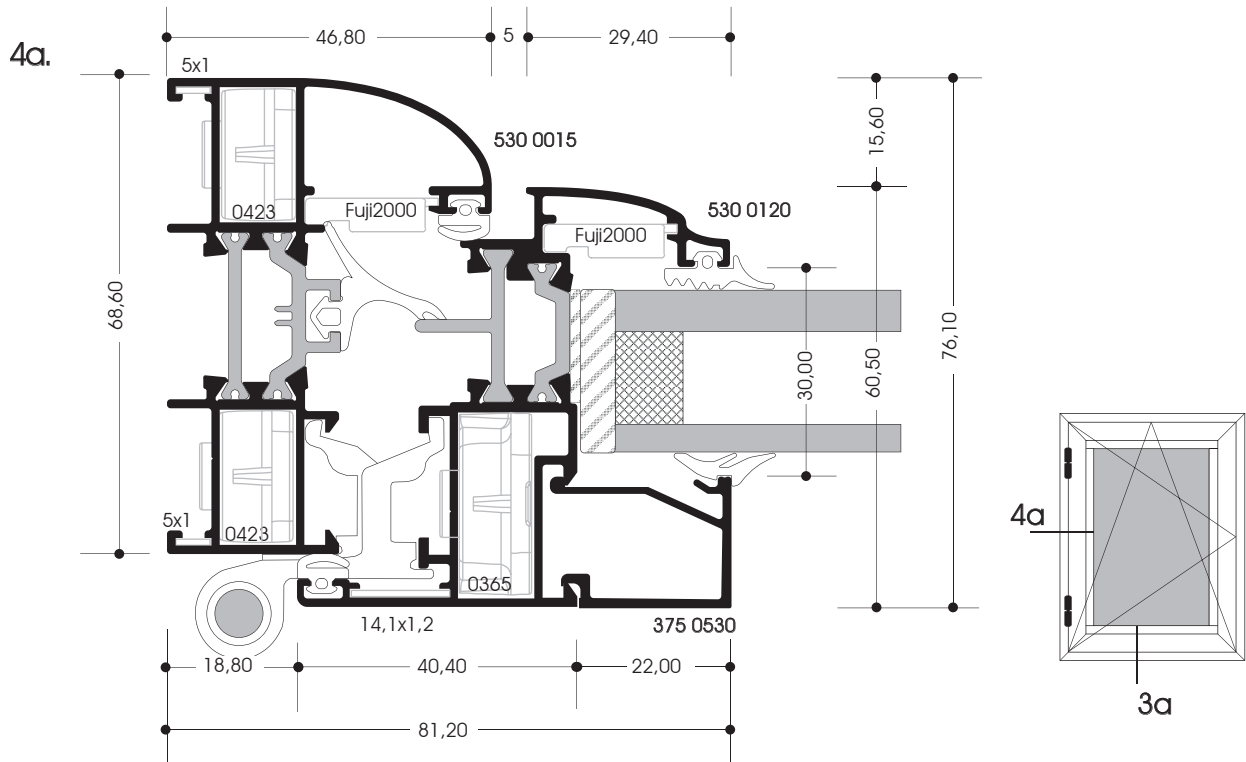

## SECTIONS

5.

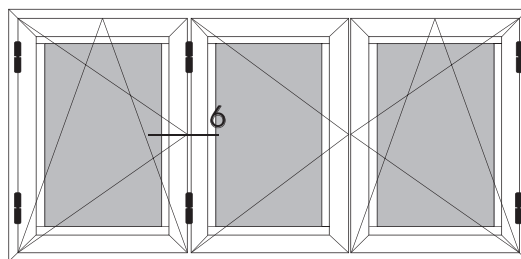
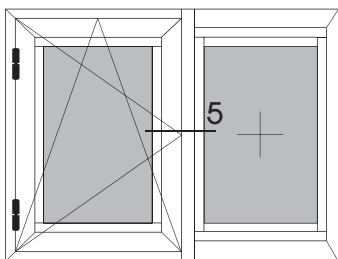
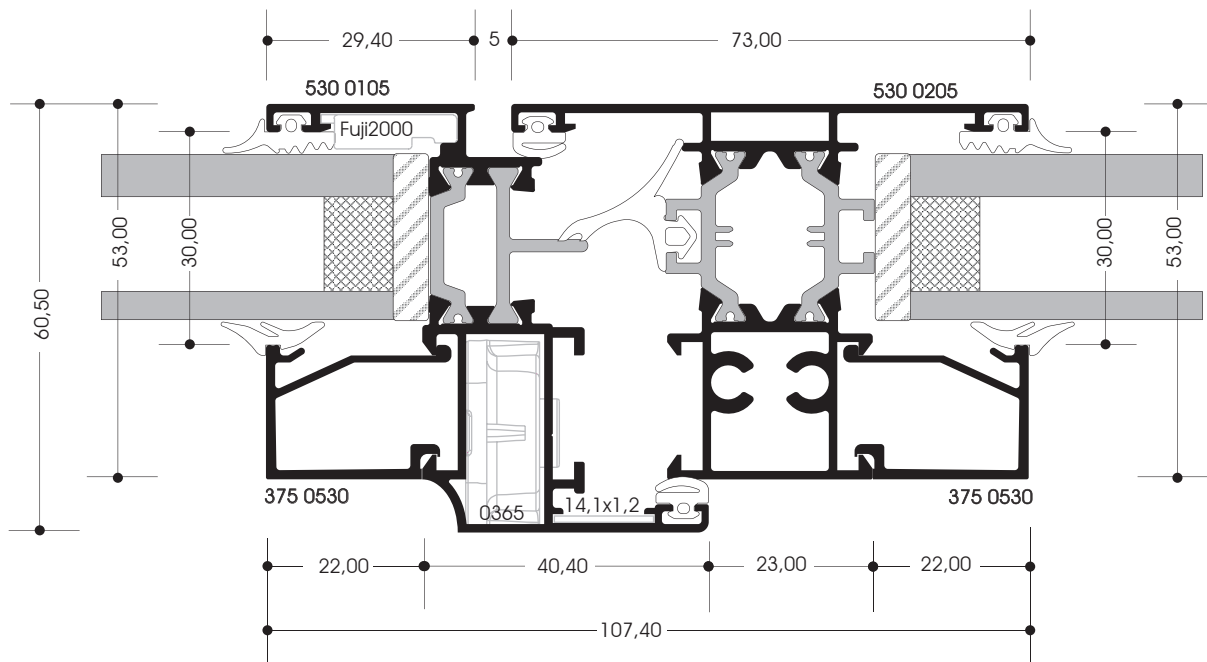

6.

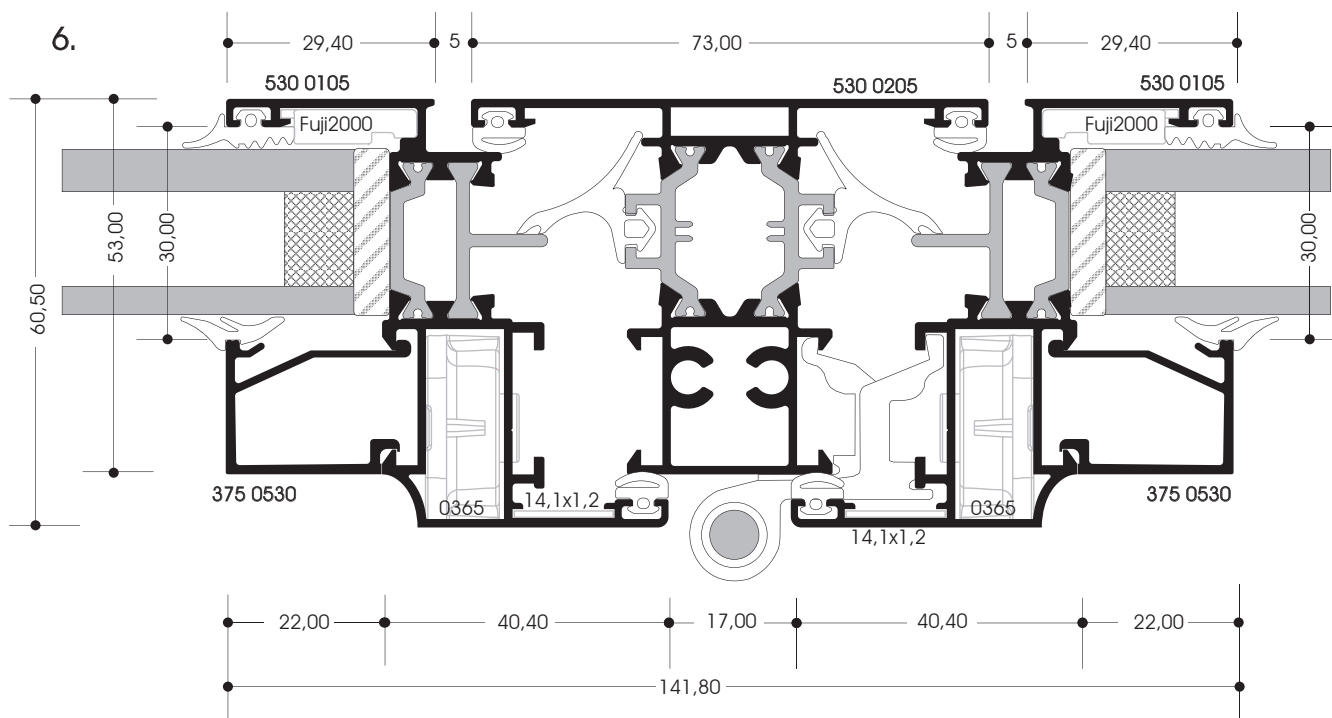

## SECTIONS

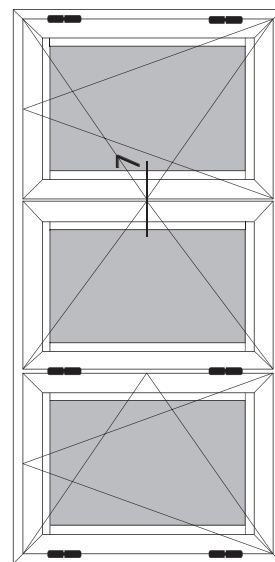
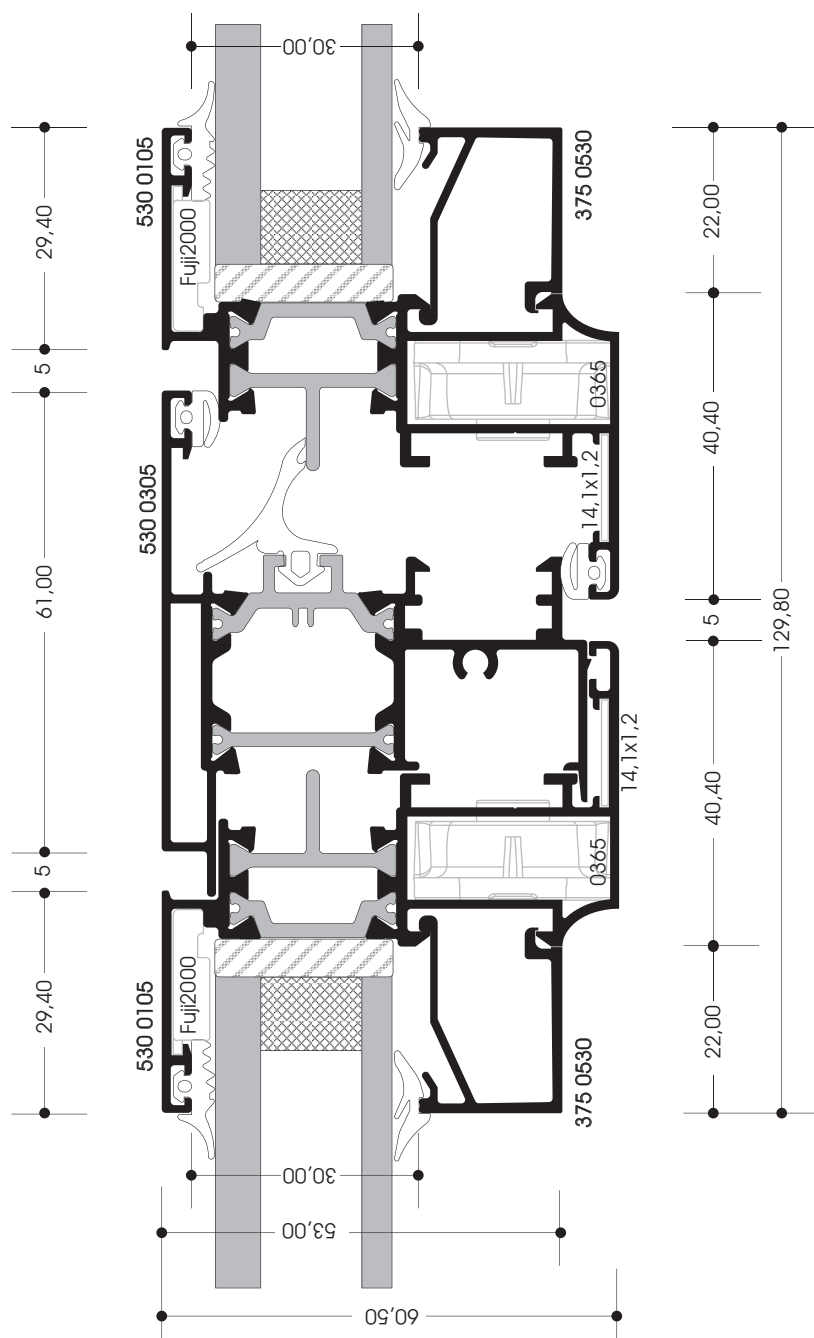

7.

## SECTIONS

8.

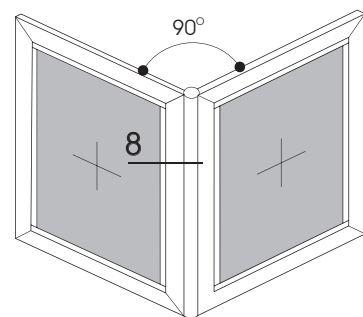
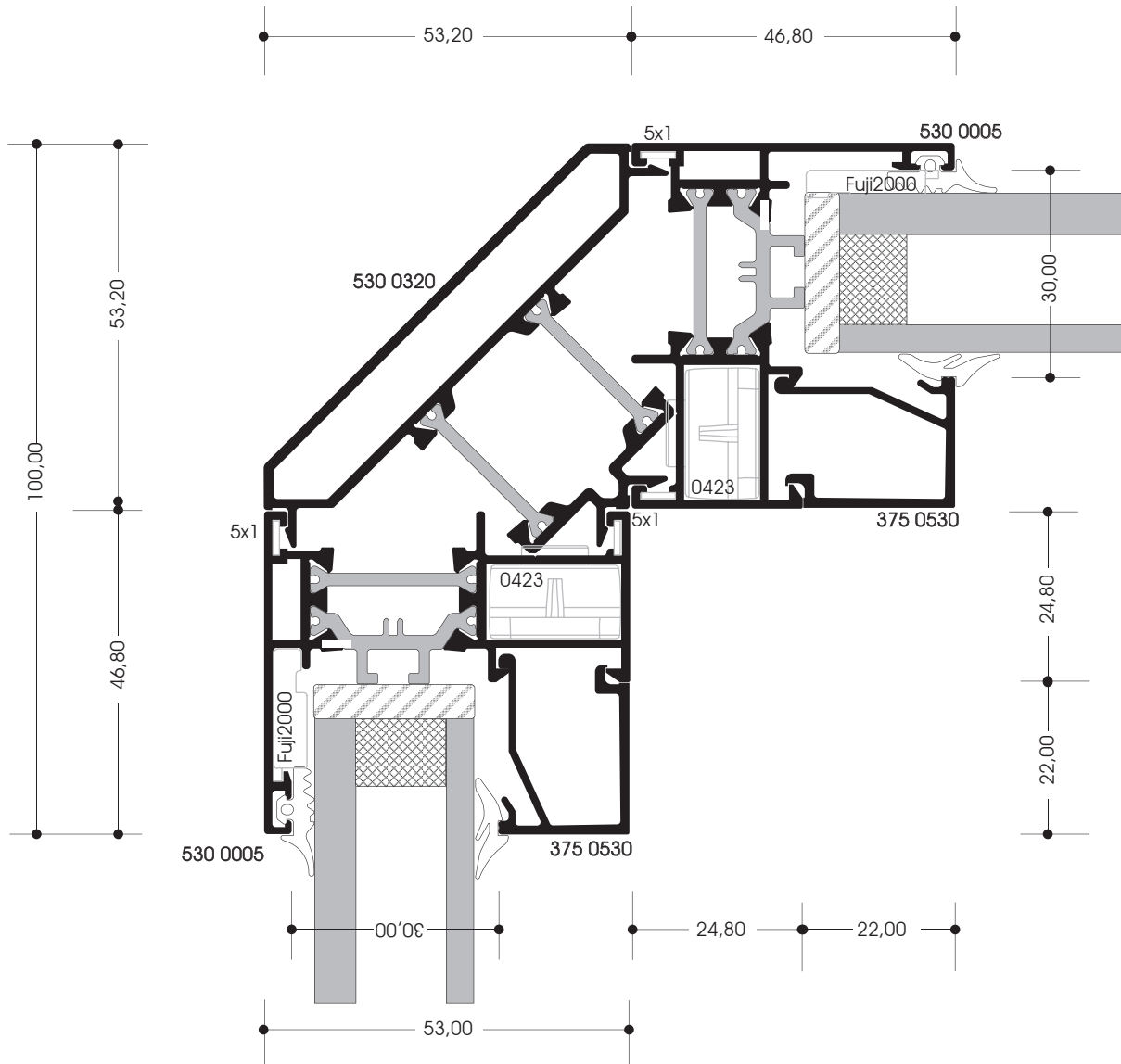

## SECTIONS

9.

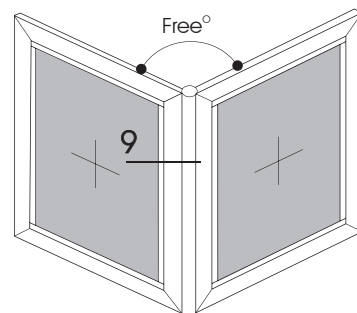
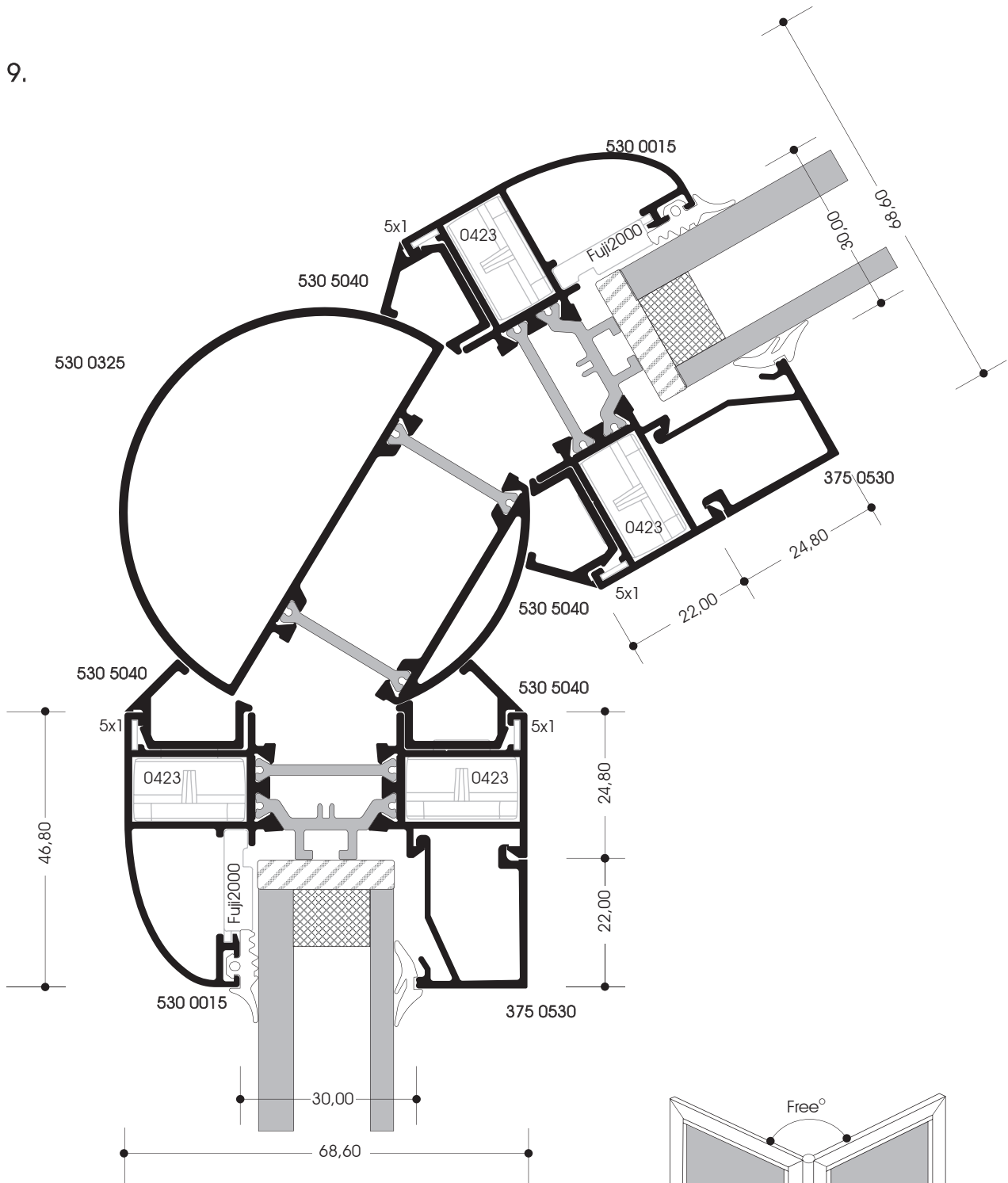

## SECTIONS

10.

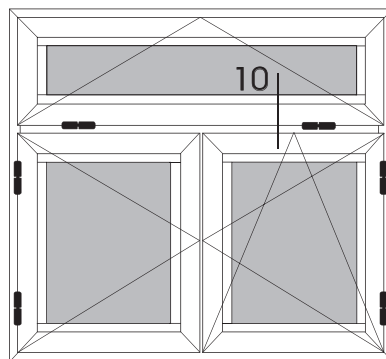
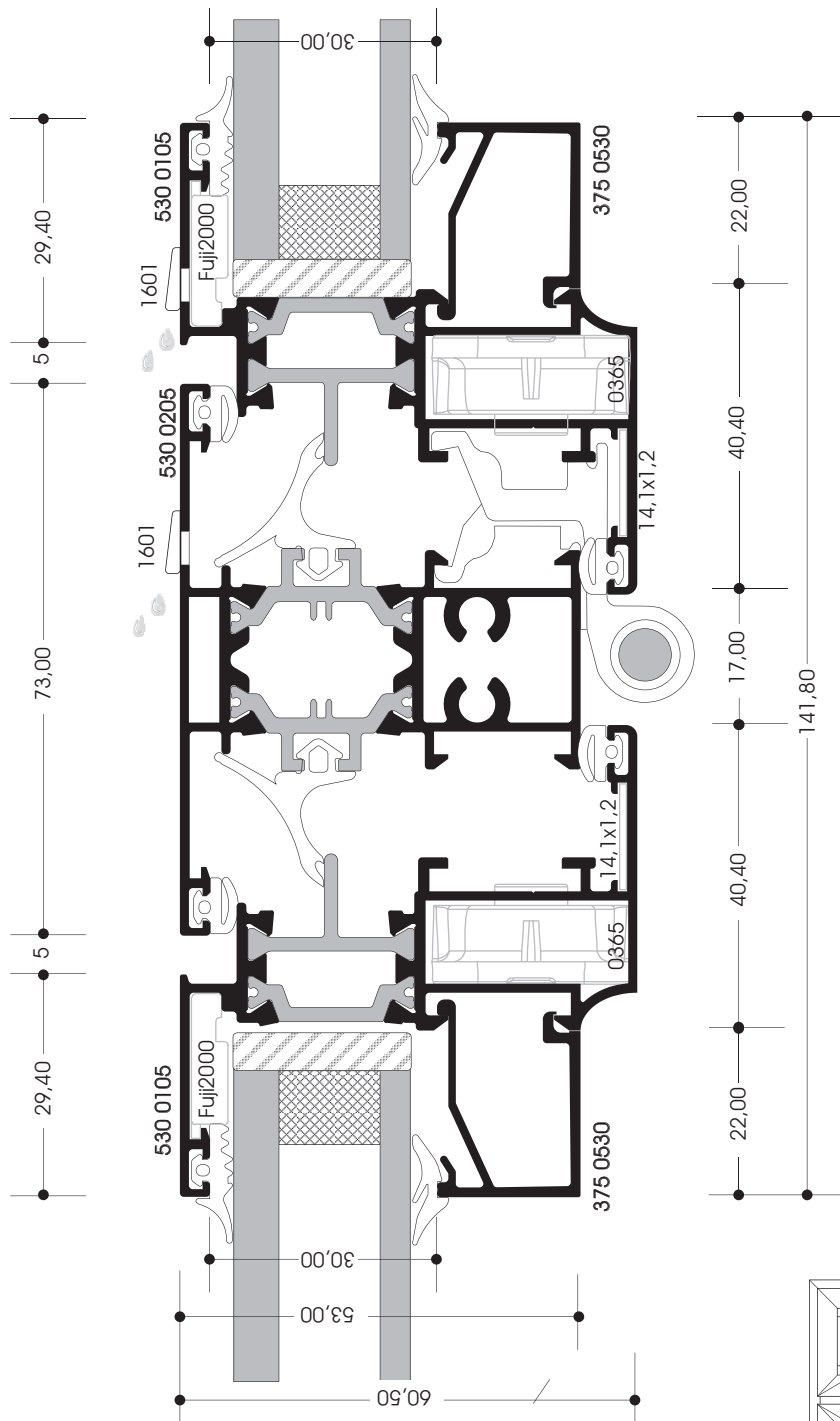

## SECTIONS

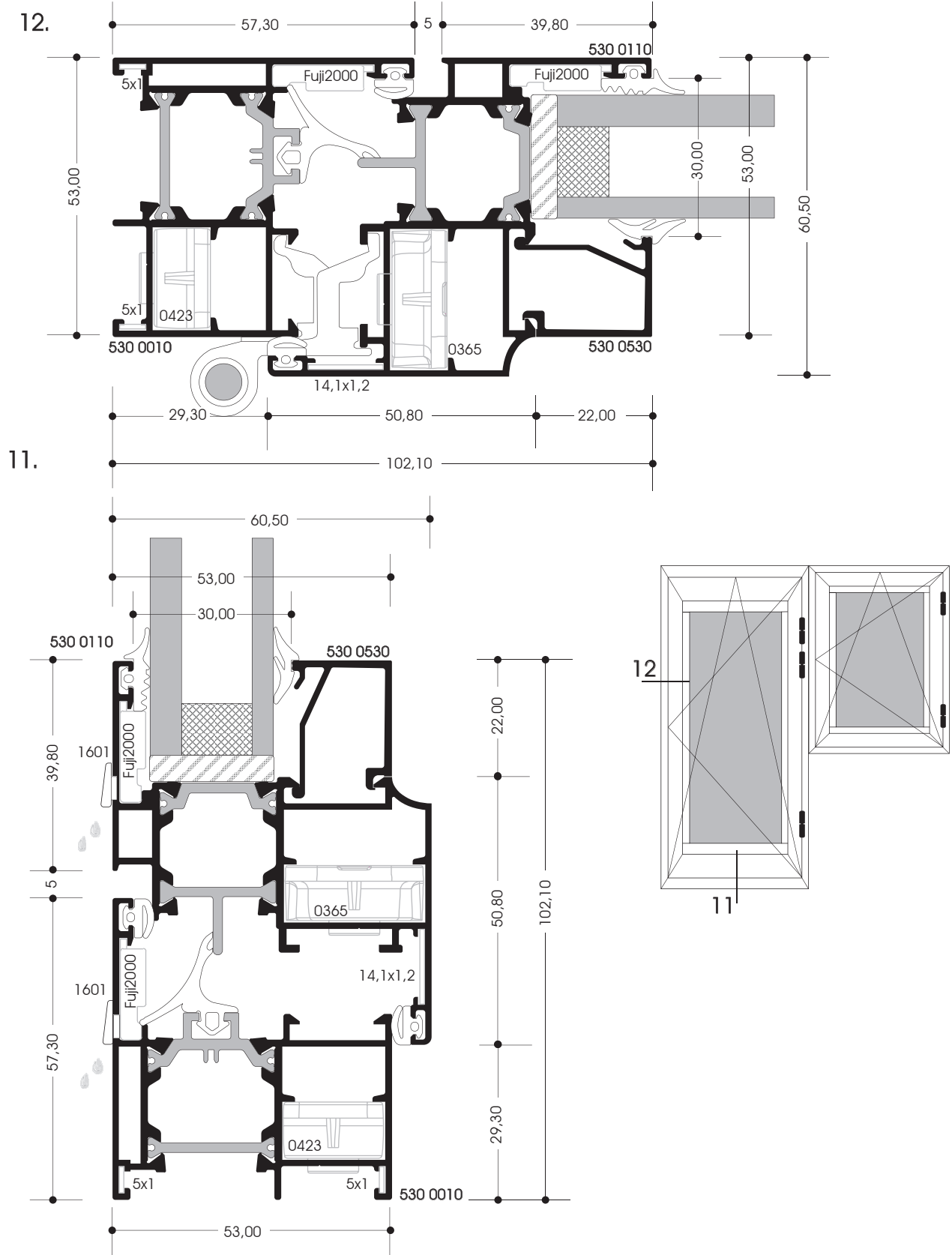



## SECTIONS

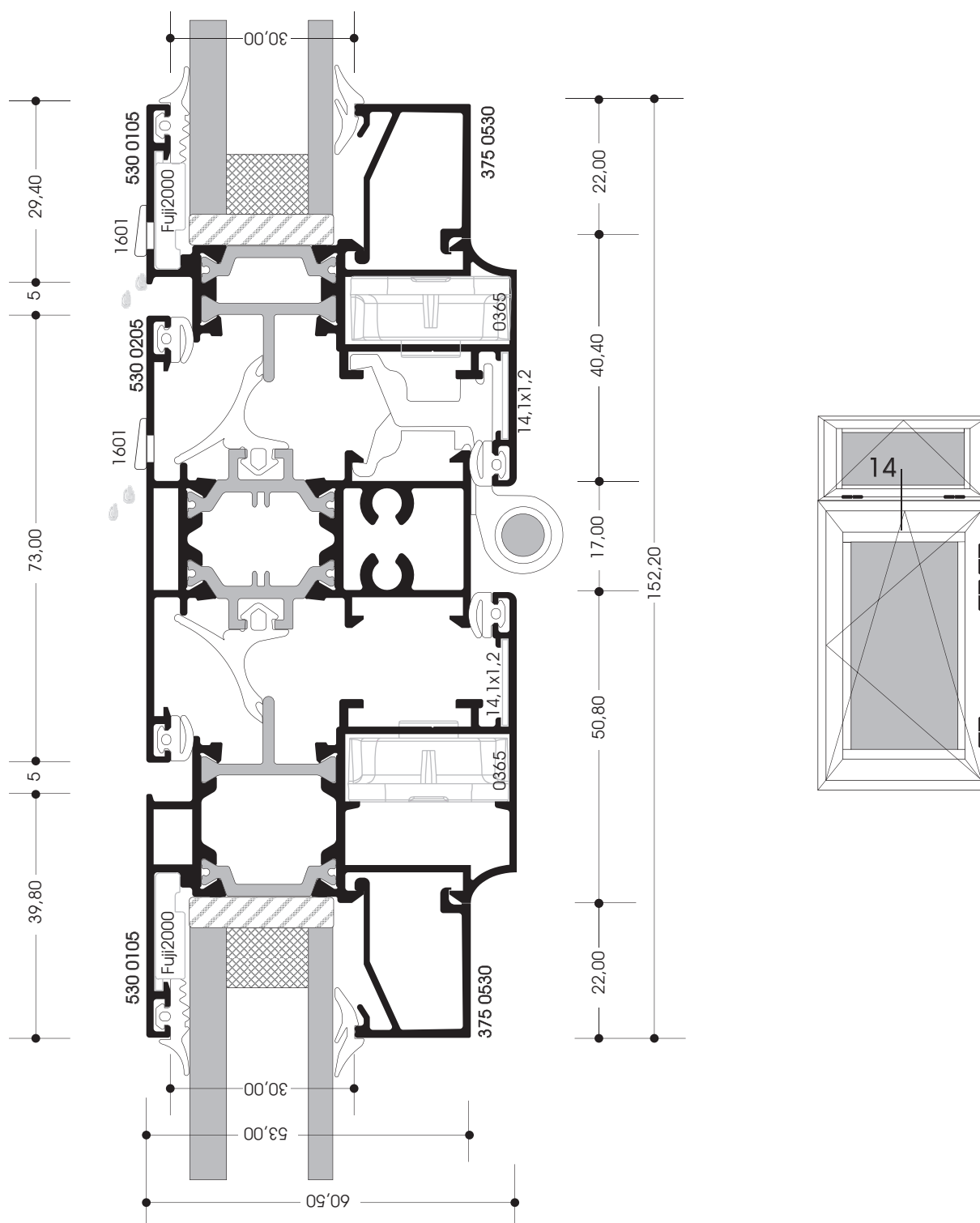

## SECTIONS

15.

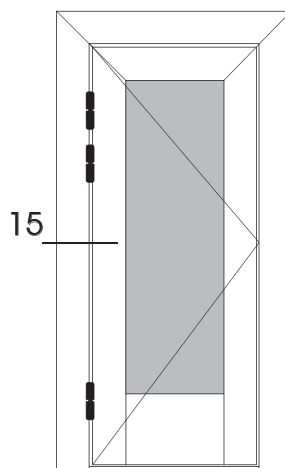
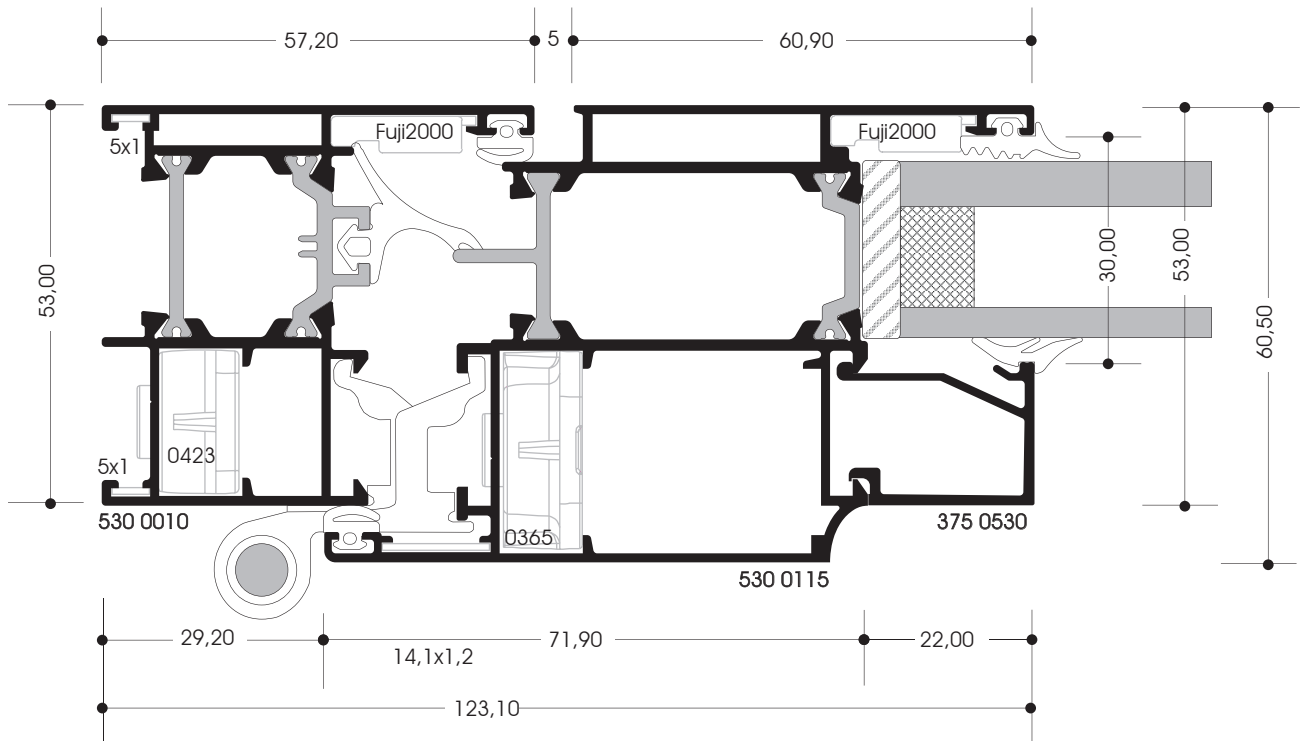

## SECTIONS

16.

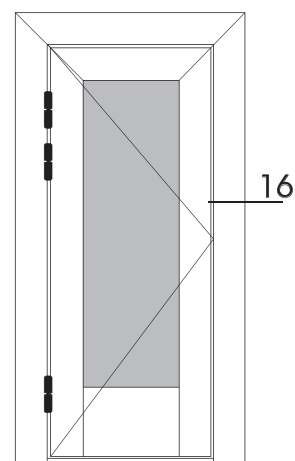
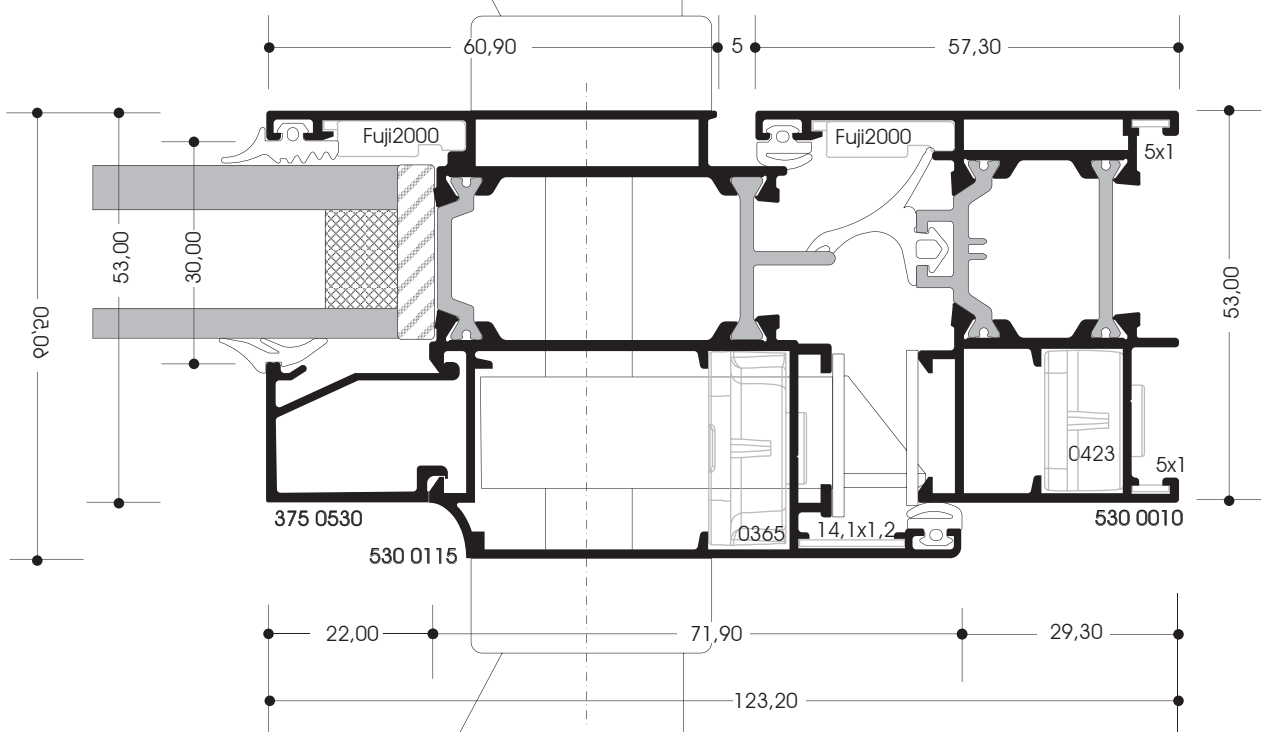

## SECTIONS

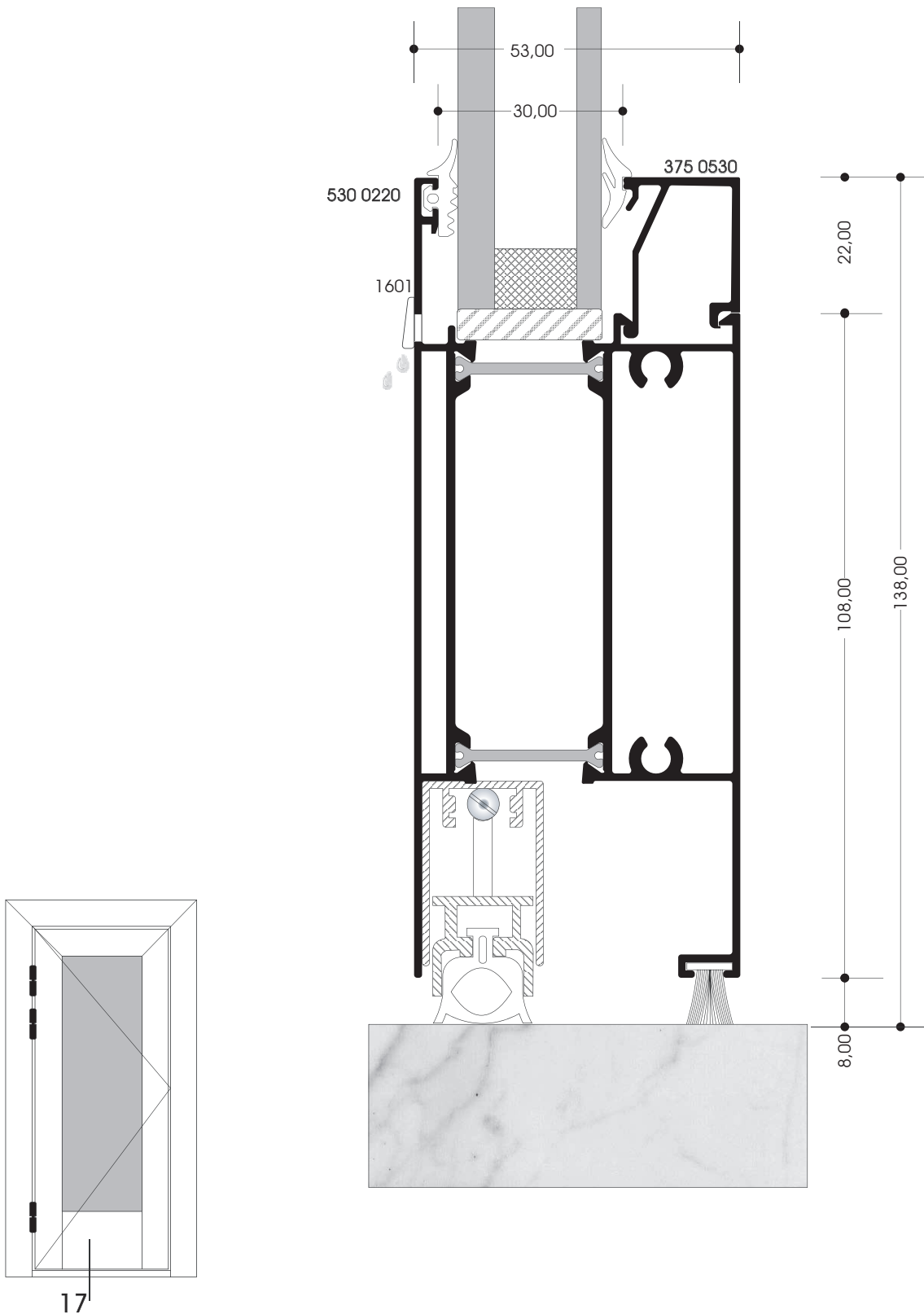

## SECTIONS

18.

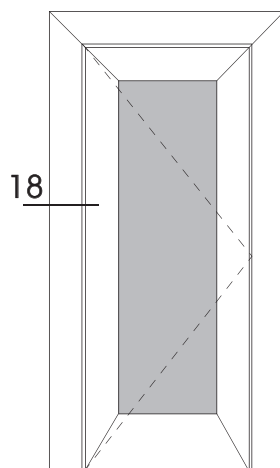
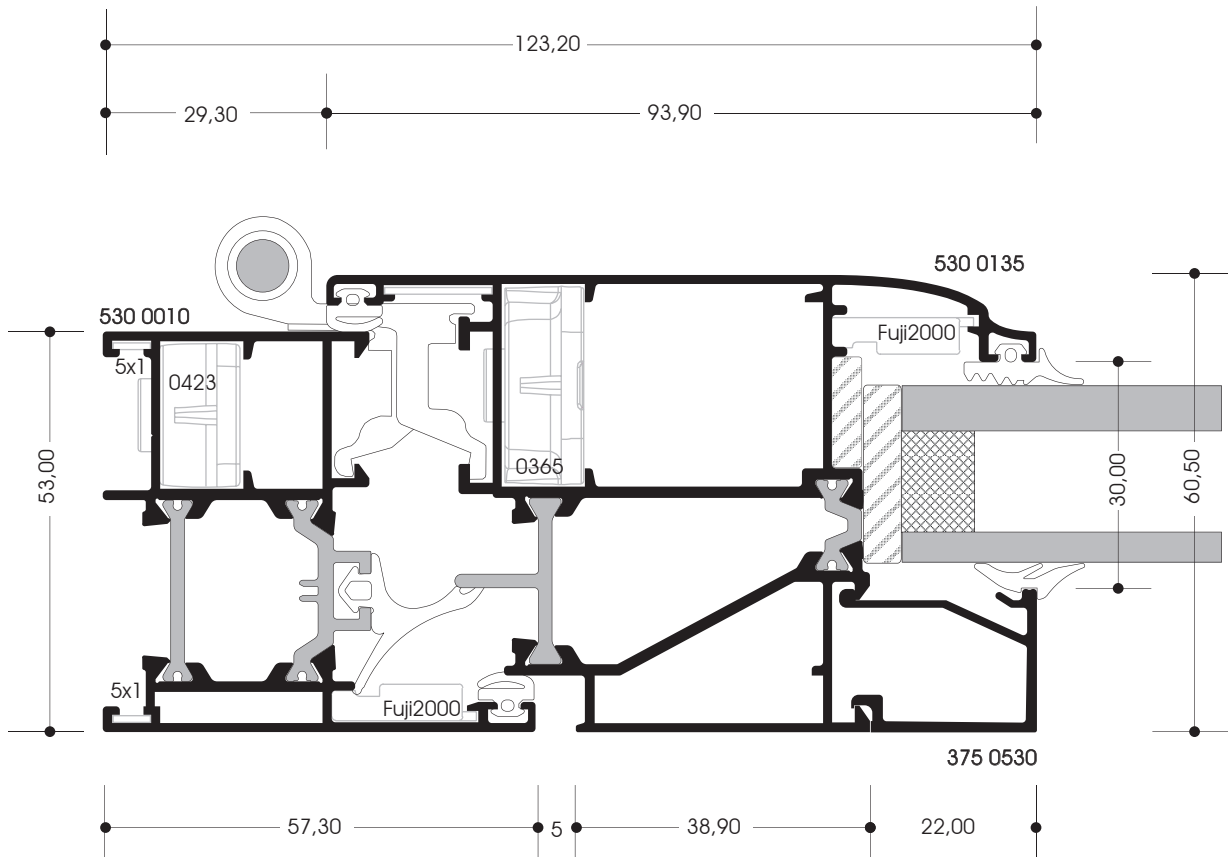

## SECTIONS

19.

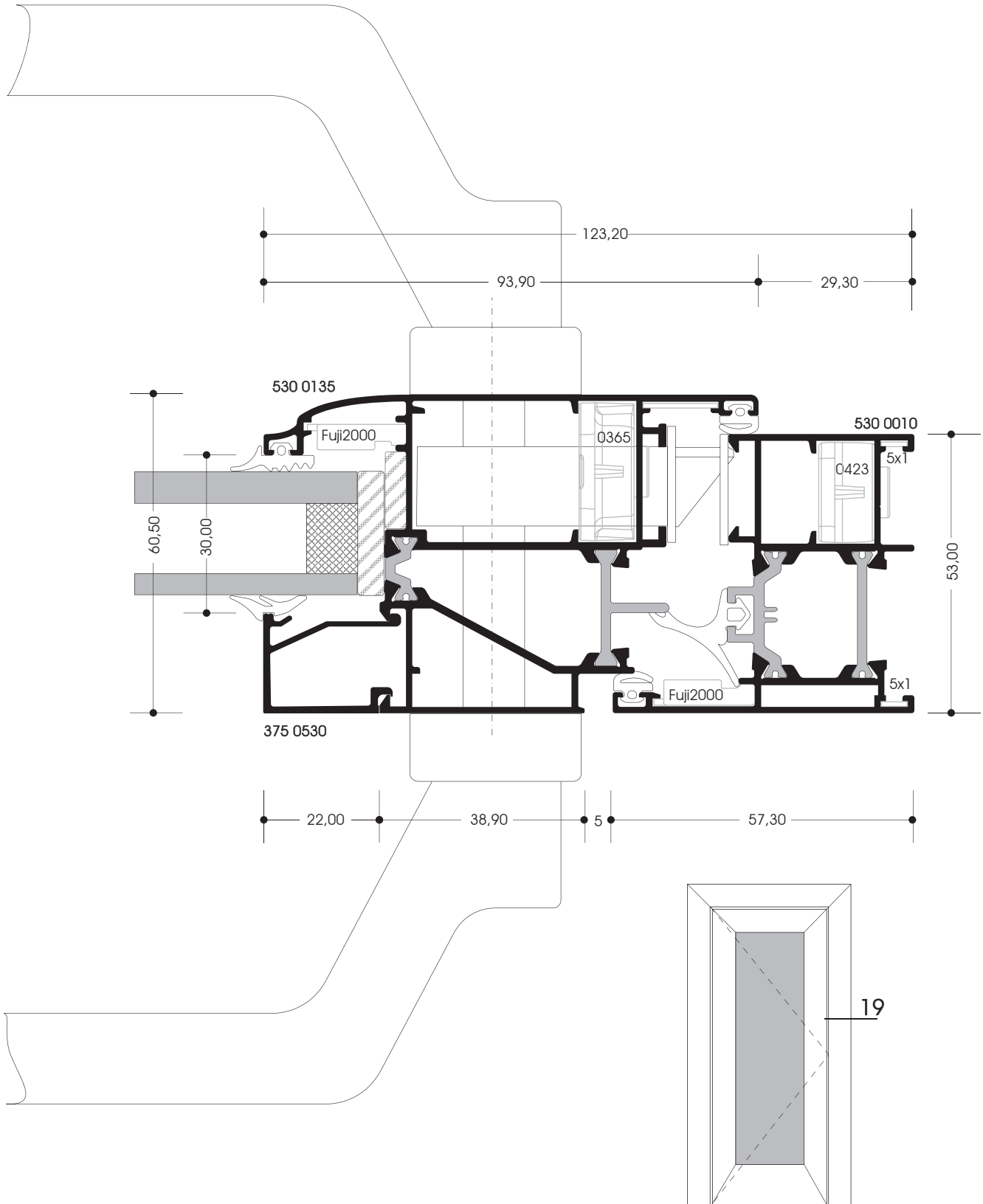

## SECTIONS

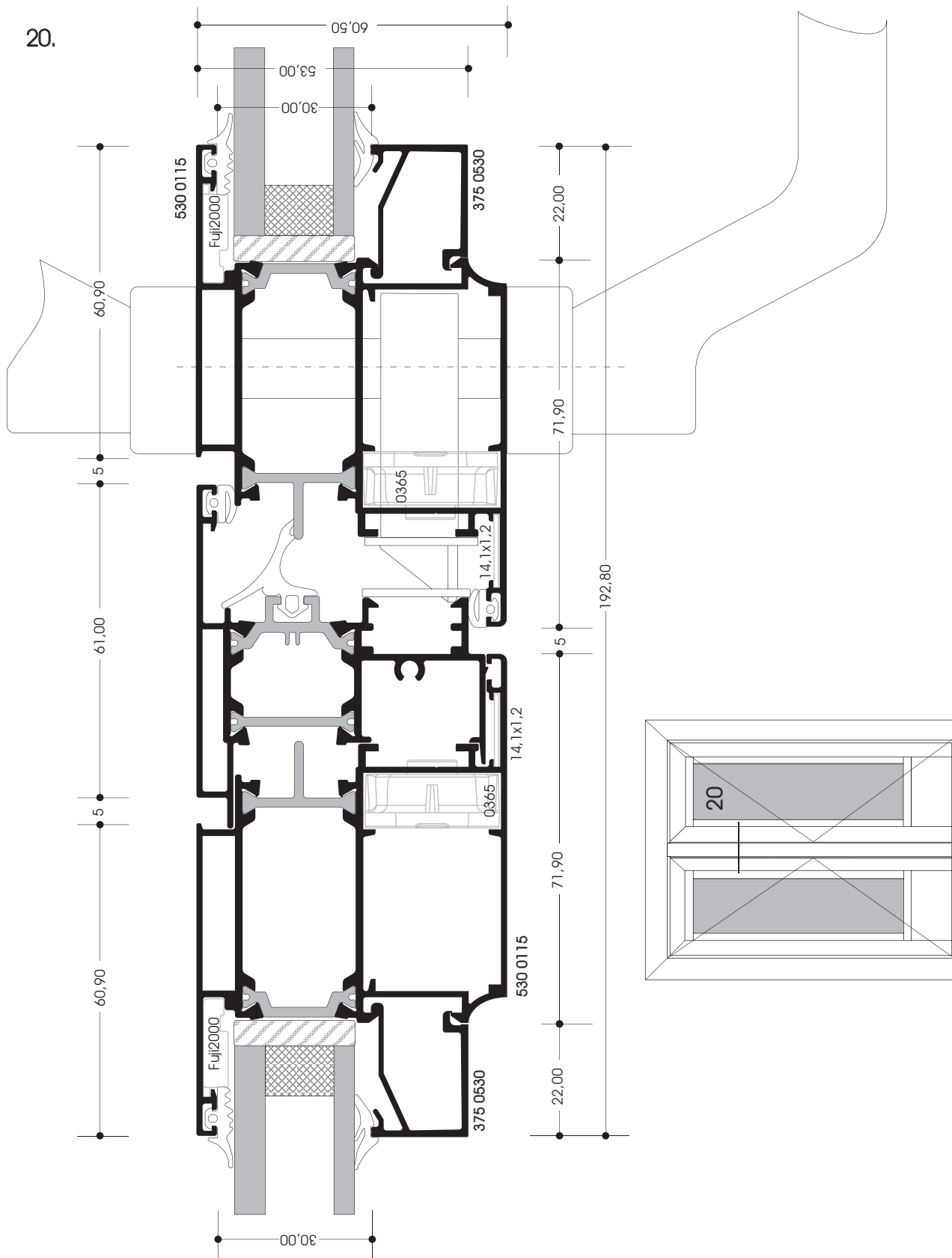

## SECTIONS

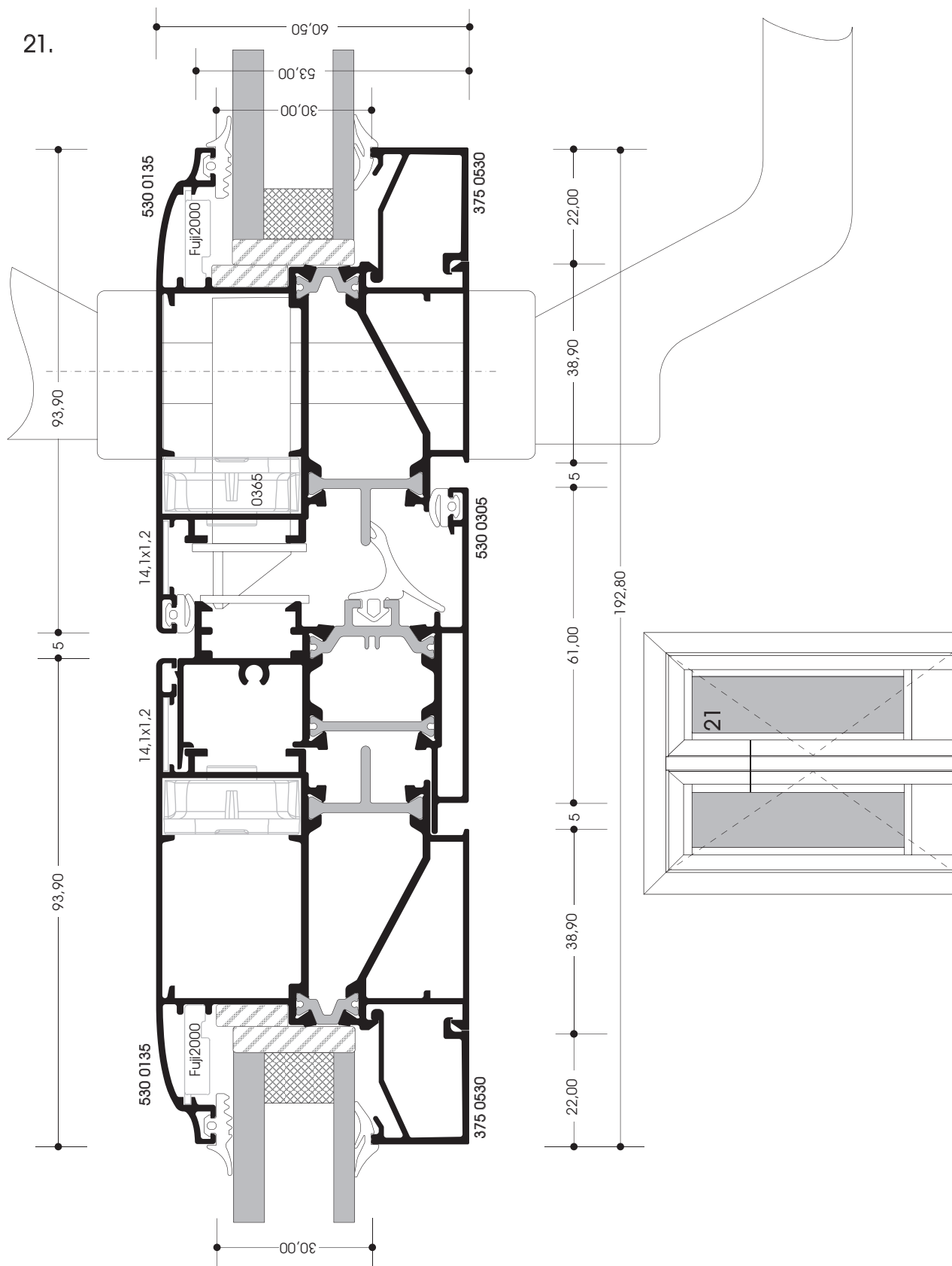

## SECTIONS

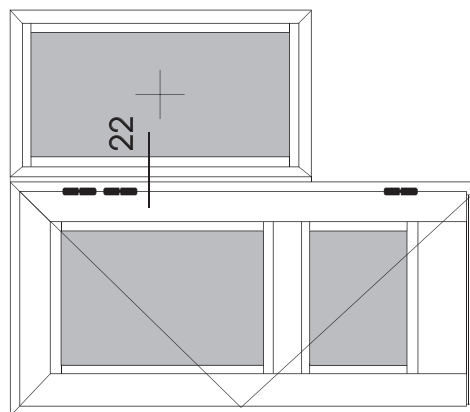
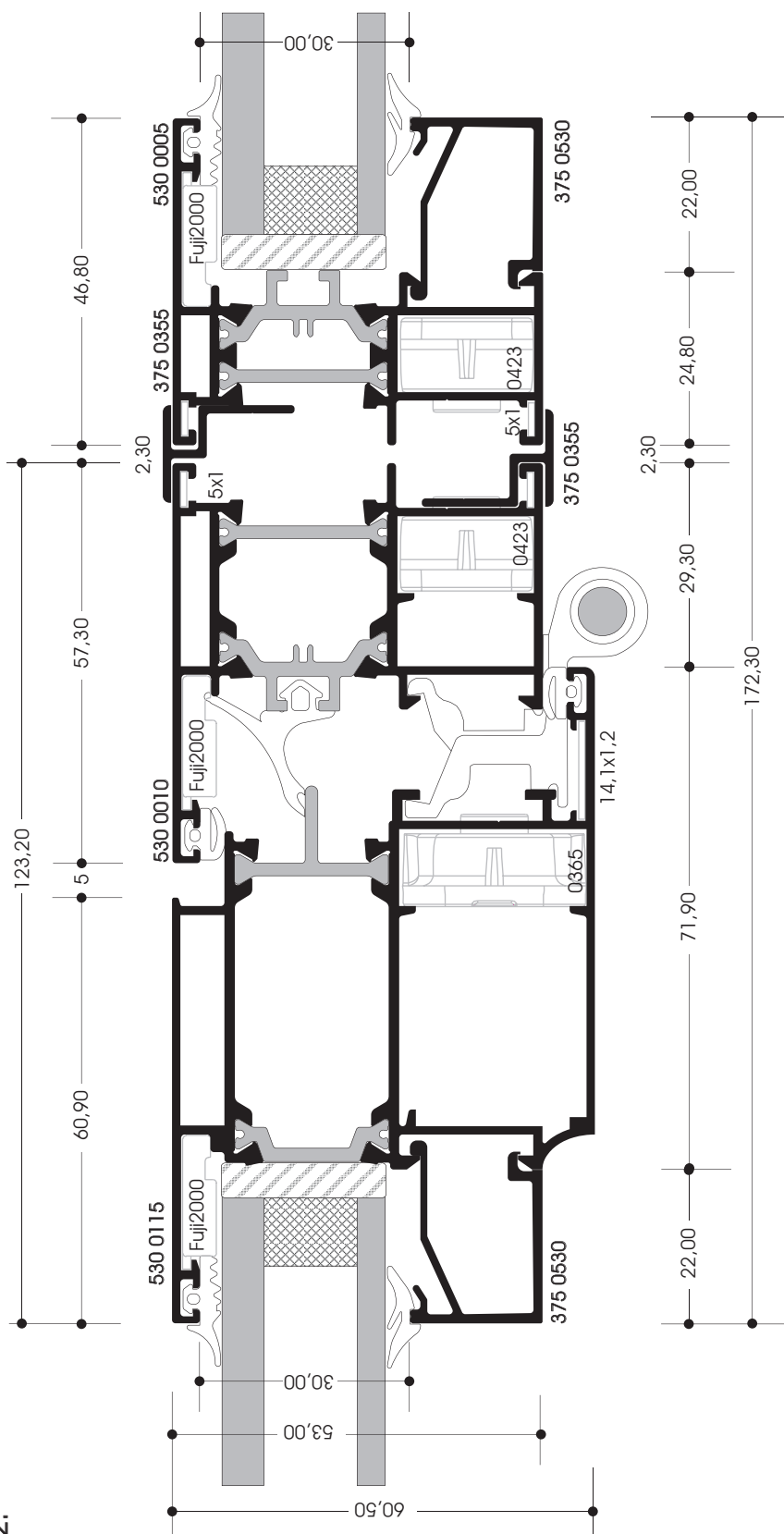

## SECTIONS

23.

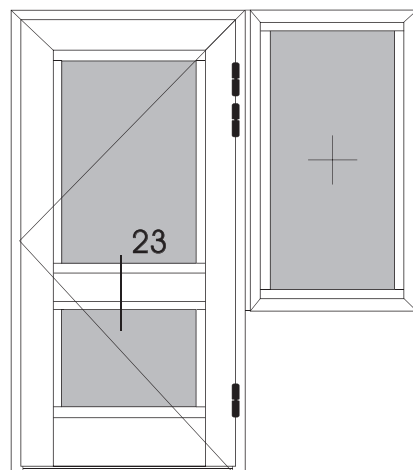
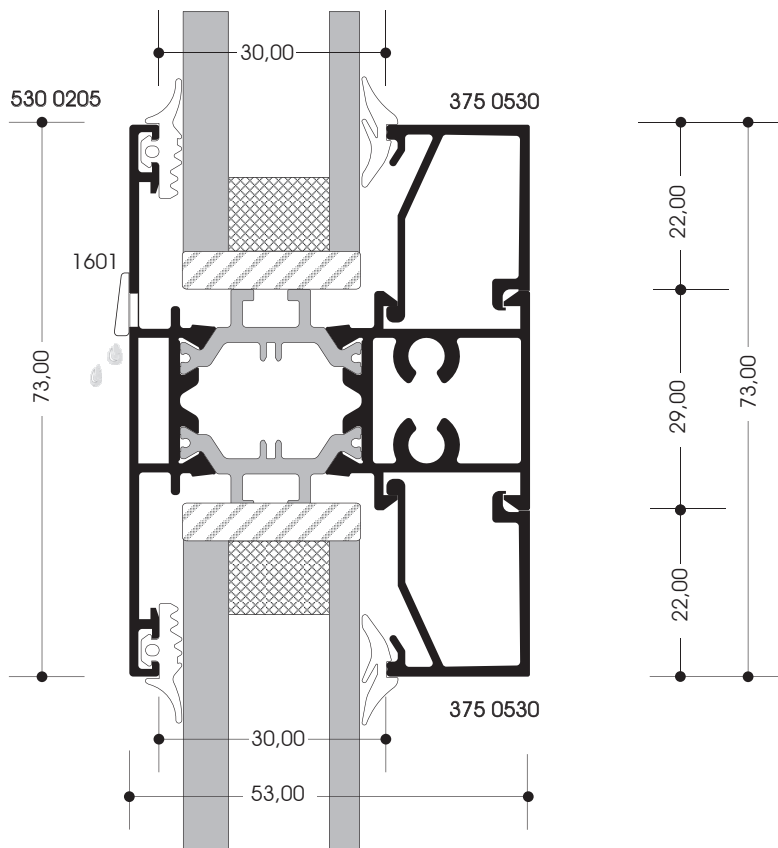

## SECTIONS

24.

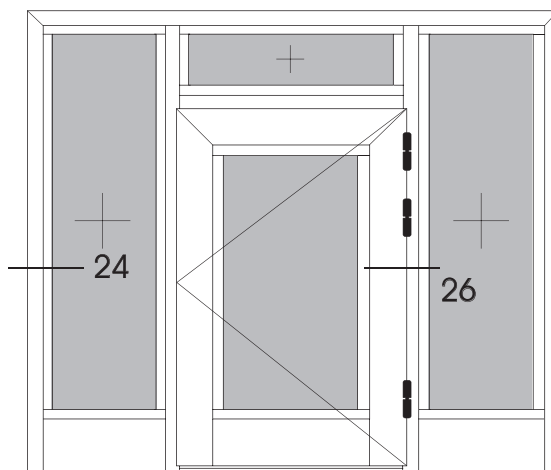
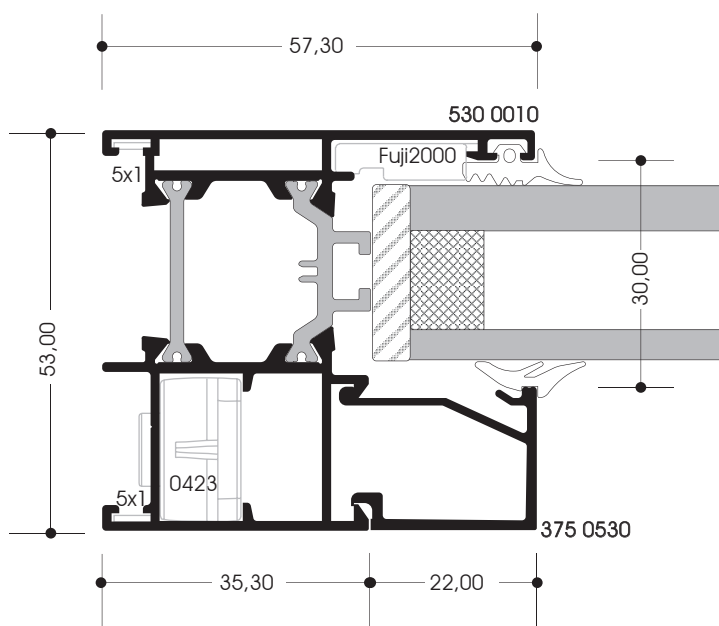

26.

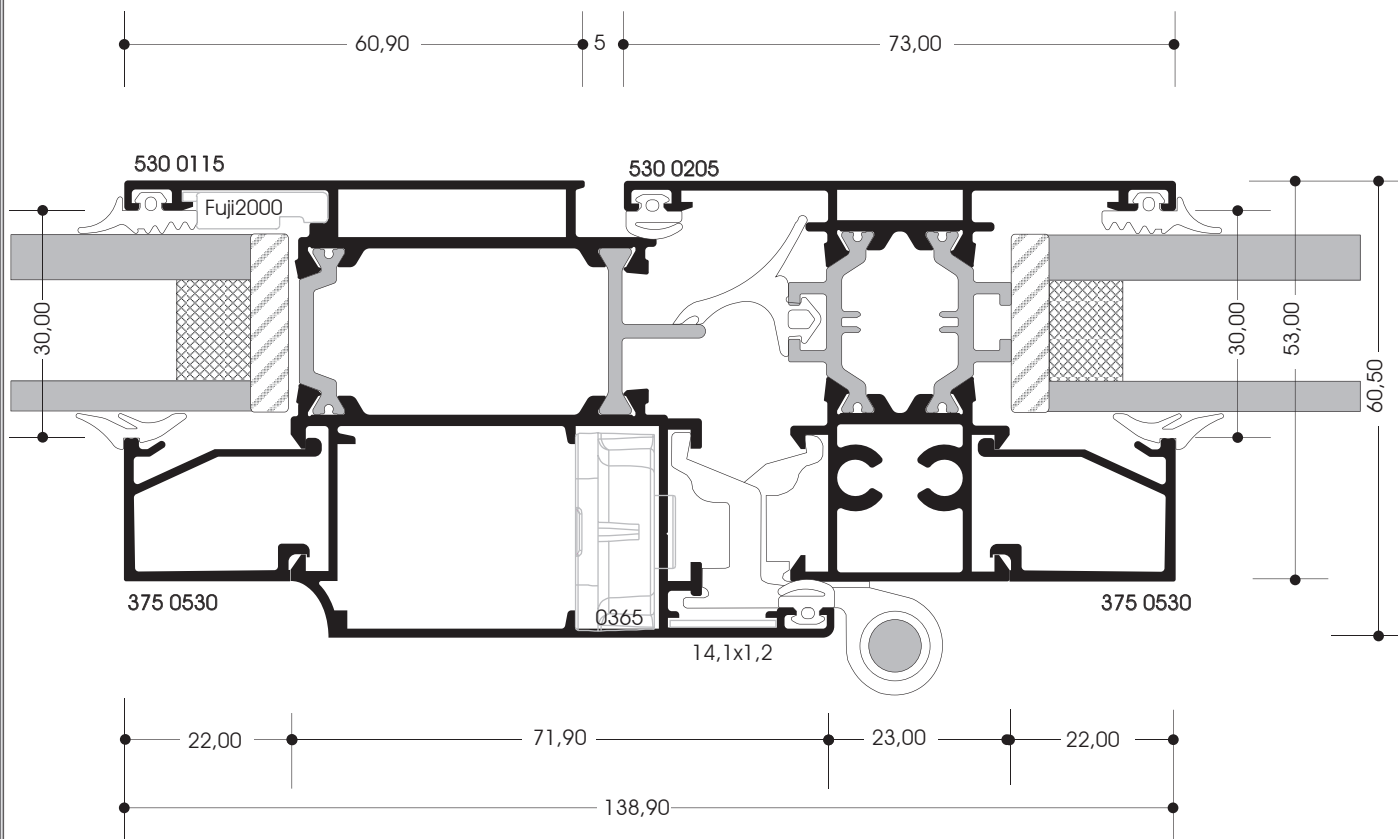

## SECTIONS

25.

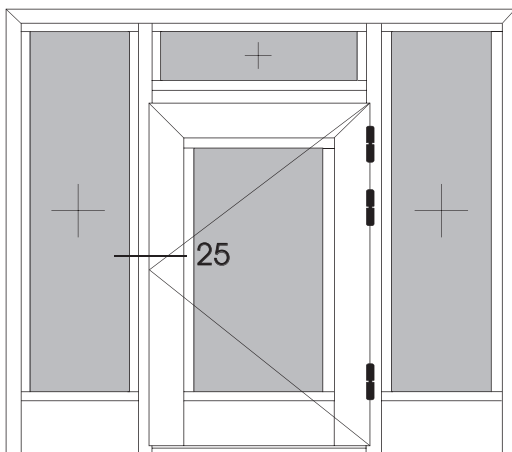
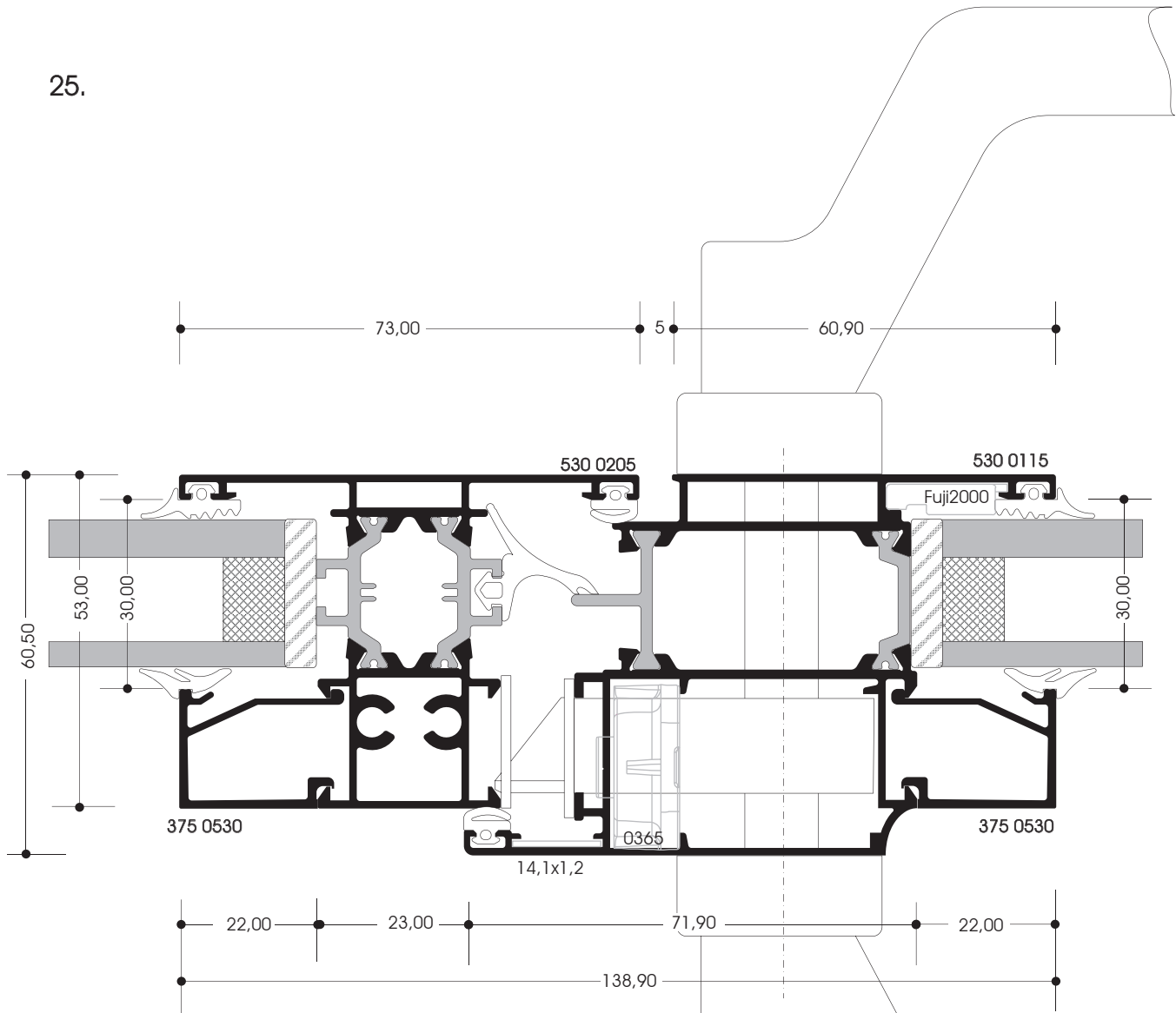

## SECTIONS

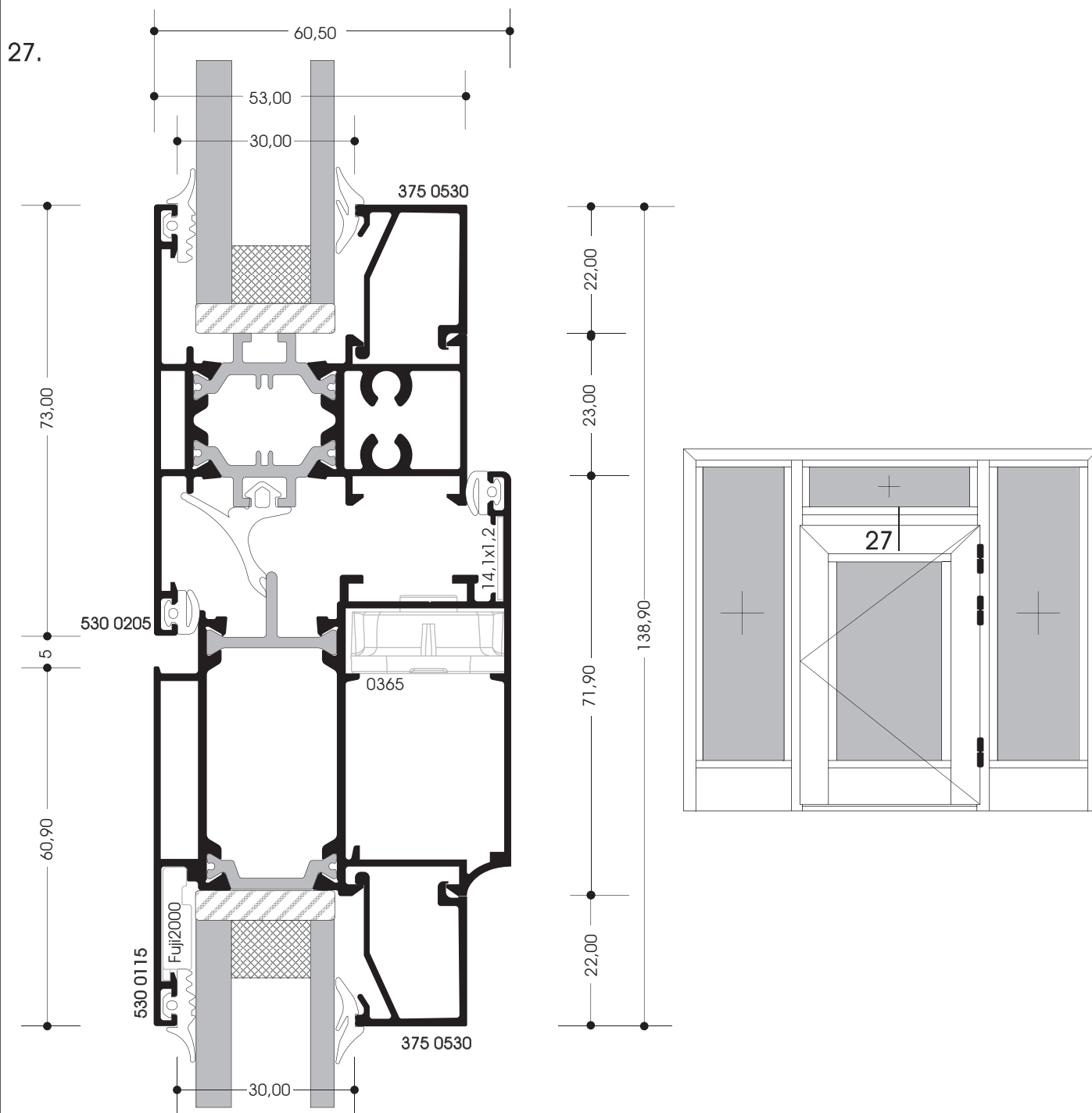

## SECTIONS

28.

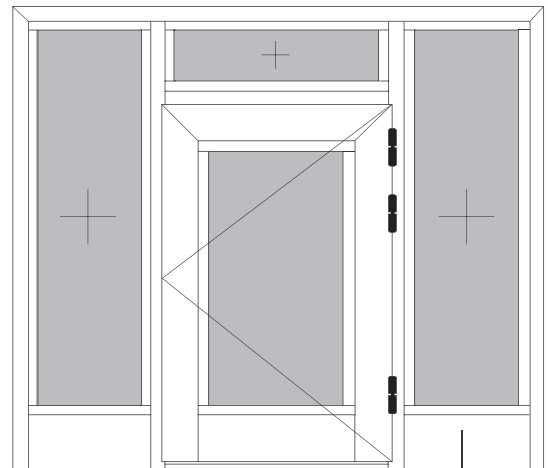
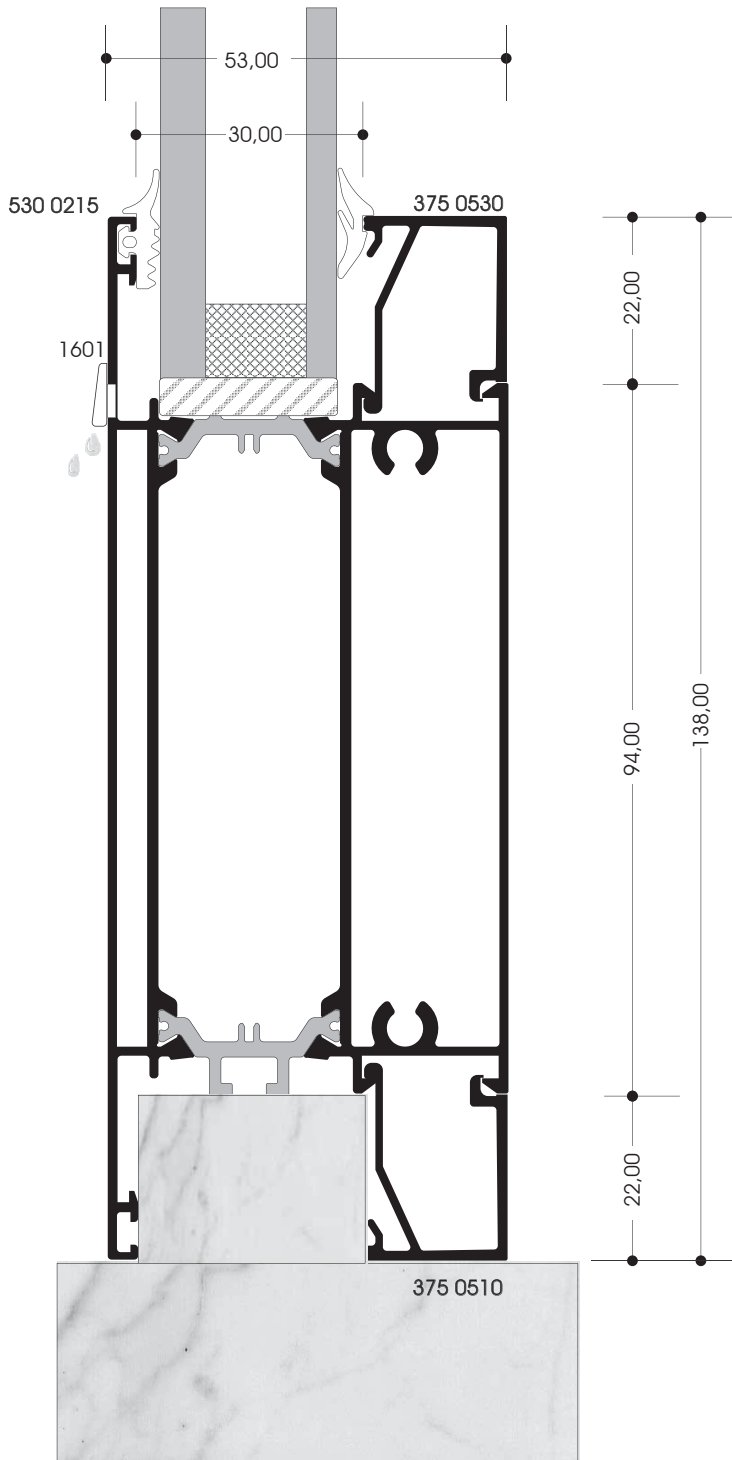

28

## SECTIONS

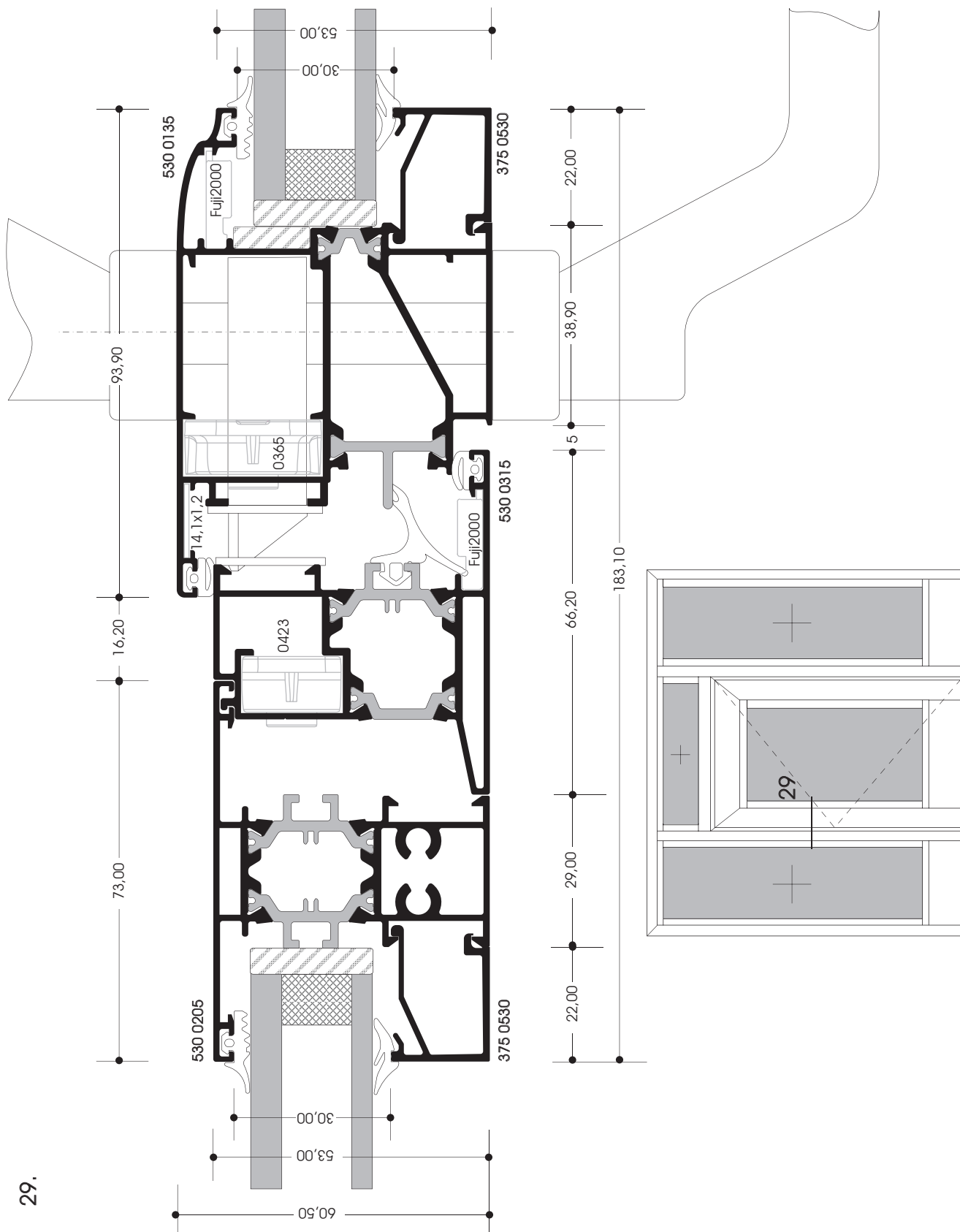

## SECTIONS

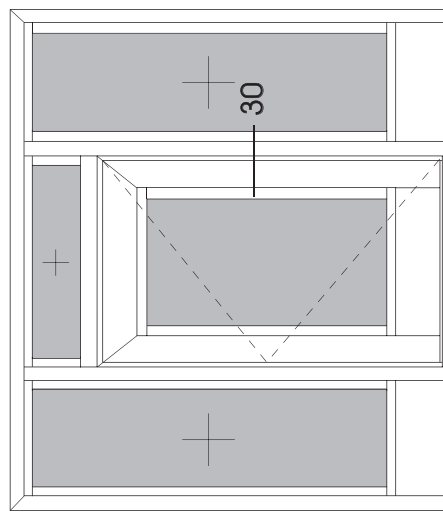
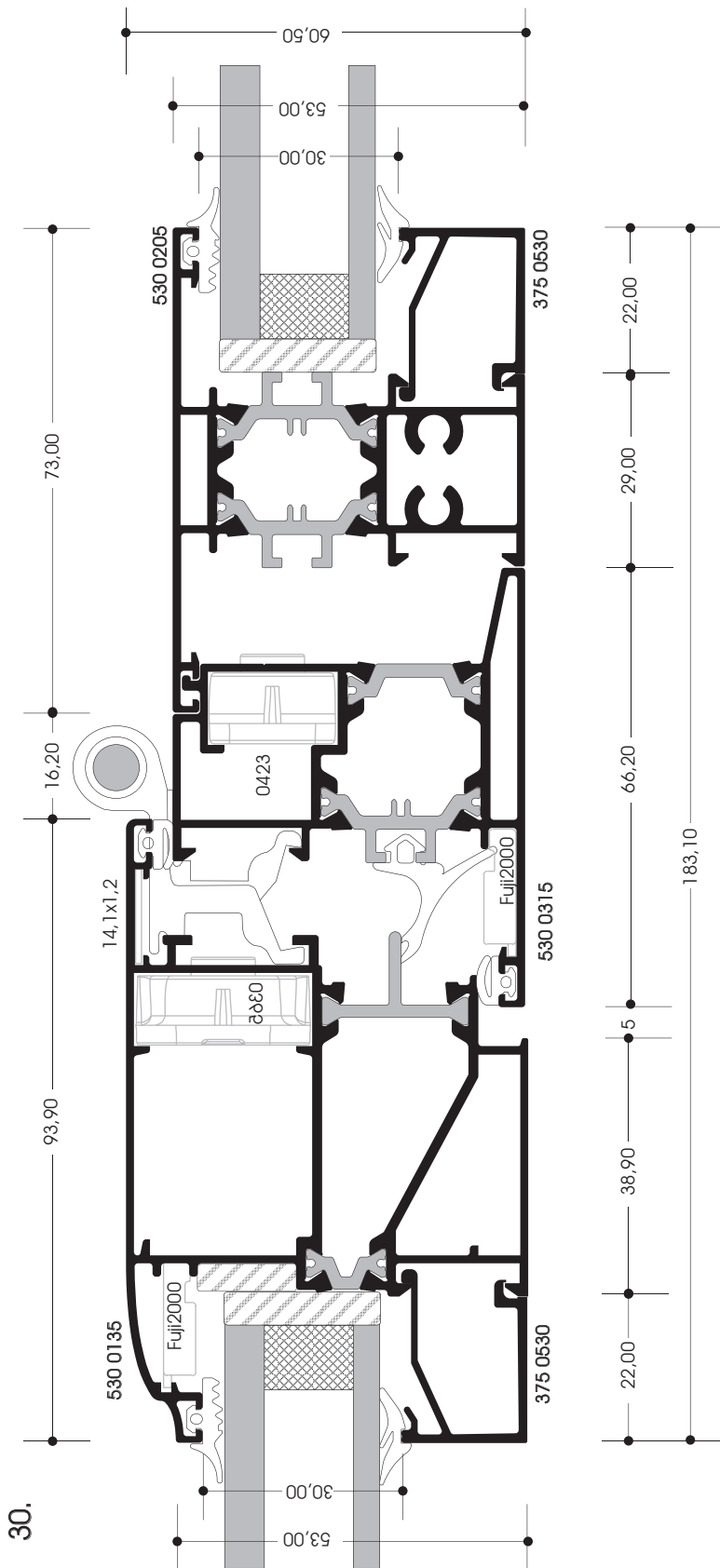

## SECTIONS

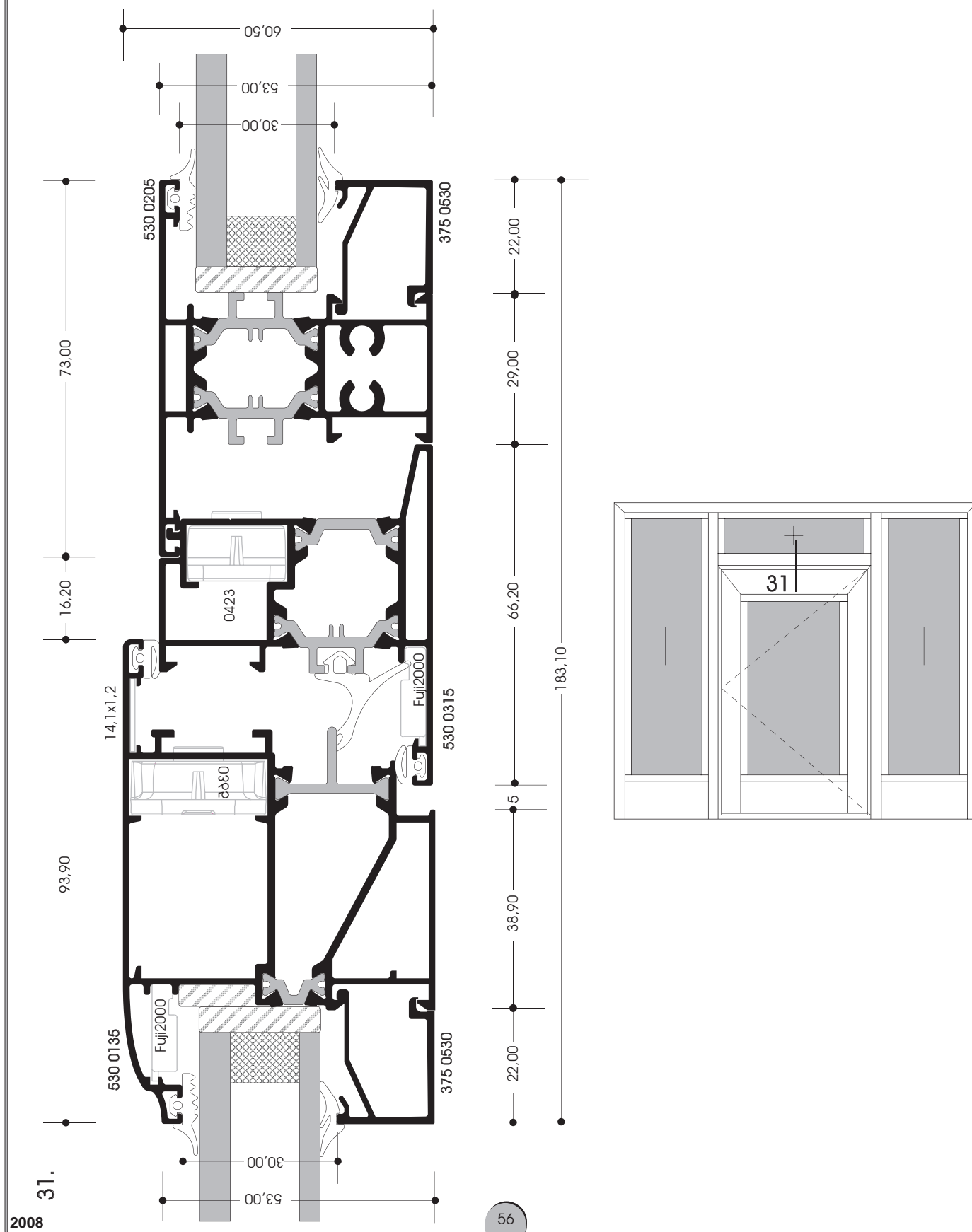

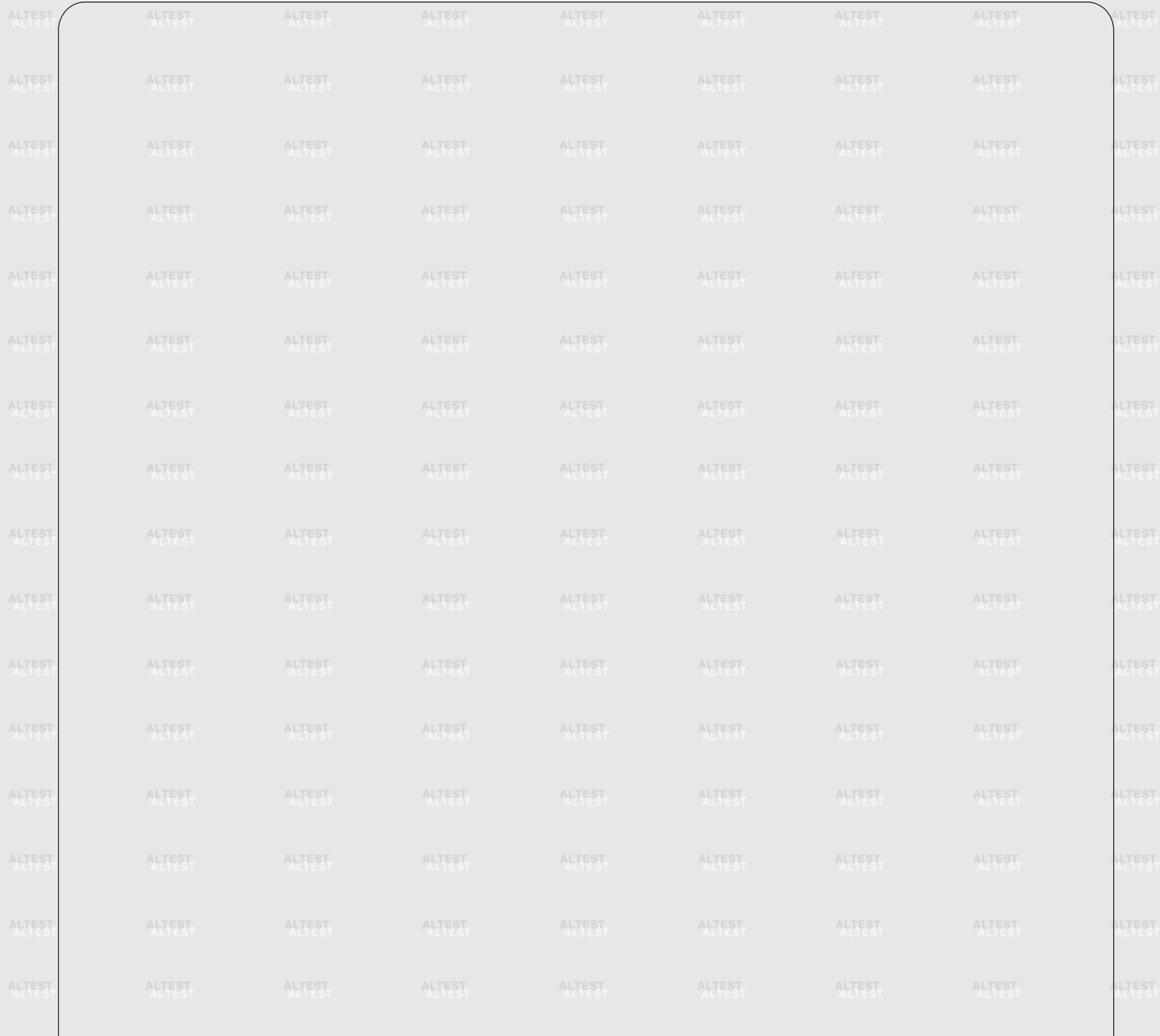

# Scheme



## SCHEME

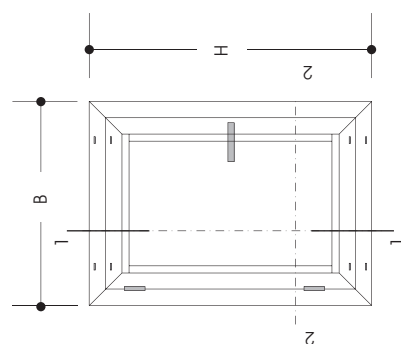

PROFILES	
FRAME	2pcs=B 2pcs=H
SASH	2pcs=B-37,60 mm 2pcs=H-37,60 mm
For frames: 530 0005, 530 0015	
GLASSHOLDER	2pcs=B-118,40 mm 2pcs=H-162,40 mm
For frames: 530 0005, 530 0015 Sash : 530 0105, 530 0120	

CONGEST GASKET	
OUTER	2pcs=B 2pcs=H
INNER	2pcs=B 2pcs=H
CENTRAL	2pcs=B 2pcs=H
GLASS OUTER	2pcs=B-118mm 2pcs=H-162mm
GLASS INNER	2pcs=B-118mm 2pcs=H-162mm

ACCESSORIES	
MECHANICAL PUTTING	0423* 0365 4pcs 4pcs
ALIGNMENT ANGLE	14,1x1,2 5x1 Fuji2000 8pcs 8pcs
DRAINAGE CAP	1601 8pcs
TWO - WAY MECHANISM	1 set
OR HINGE HANDLE	2pcs 1pcs
OR SCISSORS LATCH	2pcs 1pcs

\*For frames: 530 0015, 530 0040 - 8pcs

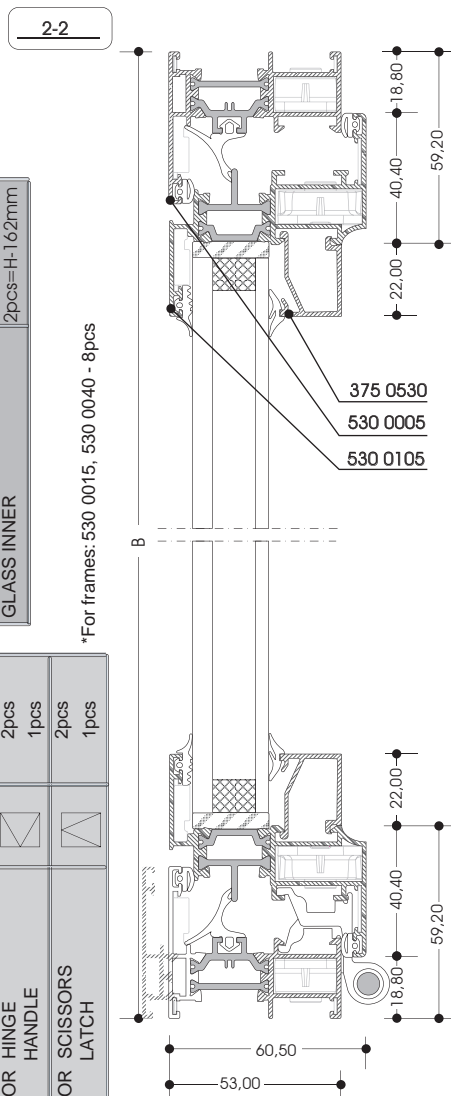
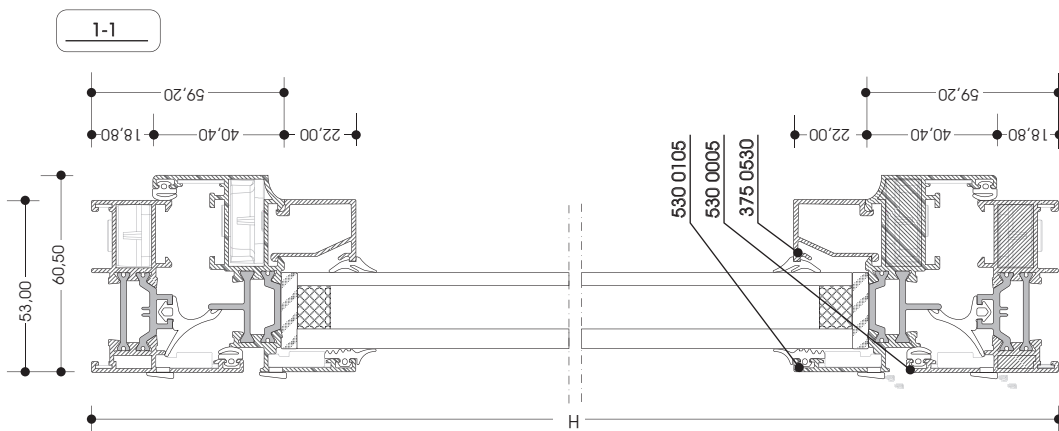

## SCHEME

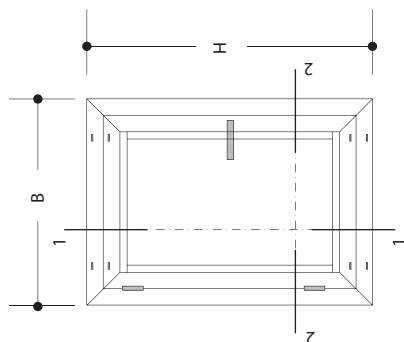

PROFILES	
FRAME	2pcs = B 2pcs = H
SASH	2pcs = B-58,60 mm 2pcs = H-58,60 mm
For frames: 530 0010, 530 0020	
GLASSHOLDER	2pcs = B-160,20 mm 2pcs = H-204,20 mm
For frames: 530 0010, 530 0020 Sash: 530 0110, 530 0125	

CONCEST GASKET	
OUTER	2pcs = B 2pcs = H
INNER	2pcs = B 2pcs = H
CENTRAL	2pcs = B 2pcs = H
GLASS OUTER	2pcs = B-160mm 2pcs = H-204mm
GLASS INNER	2pcs = B-160mm 2pcs = H-204mm

ACCESSORIES	
MECHANICAL PUTTING	0423* 0365
ALIGNMENT ANGLE	14,1x1,2 5x1 Fuji2000
DREINAGE CAP	1601
TWO-WAY MECHANISM	1set
OR HINGE HANDLE	2pcs 1pcs
OR SCISSORS LATCH	2pcs 1pcs

+For frames 530 0020, 530 0030 - 8pcs

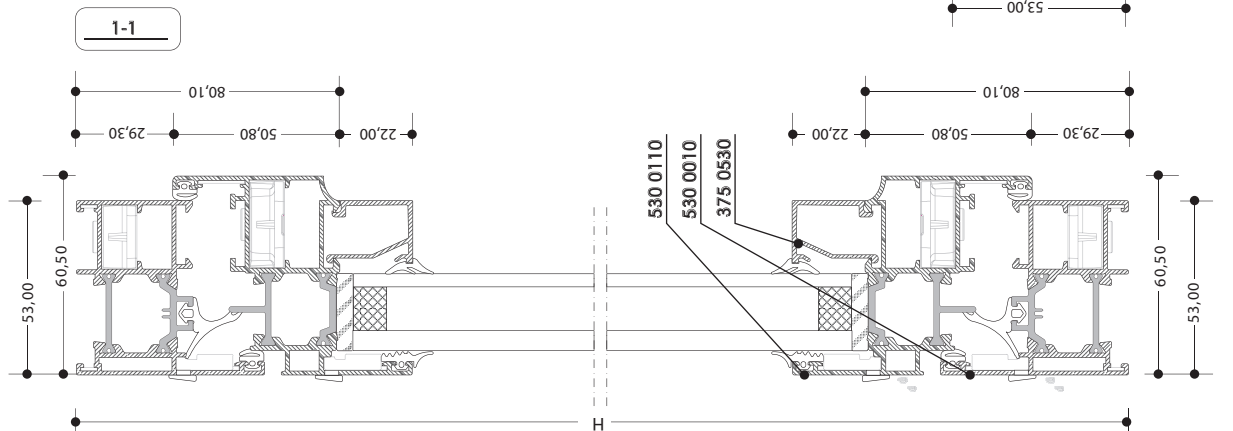

## SCHEME

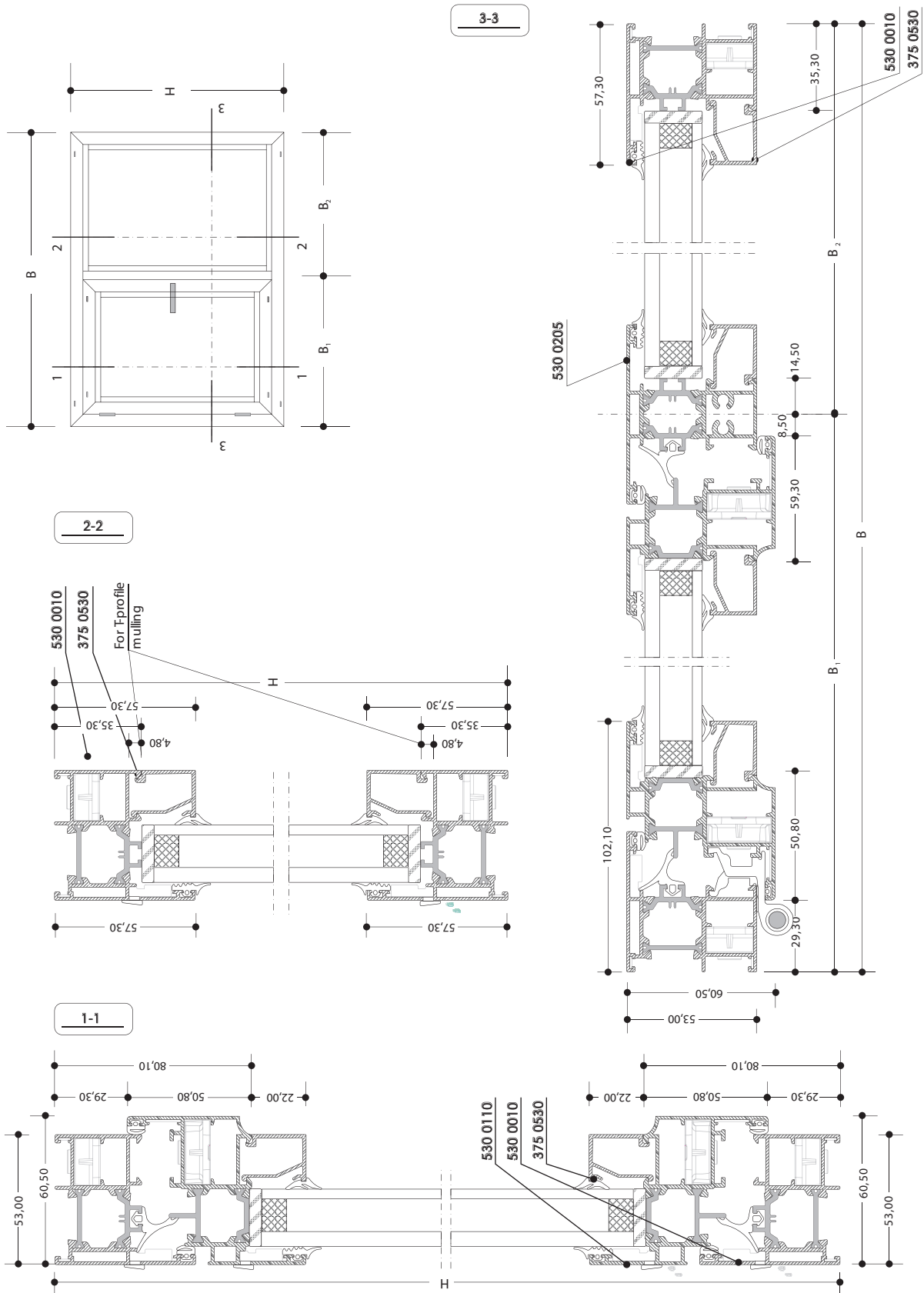

## SCHEME

PROFILES			
FRAME	2pcs=B 2pcs=H		
SASH	2pcs=B-37,80 mm* 2pcs=H-58,60 mm	*Only for 530 0205	
For frames :530 0010 , 530 0020			
GLASSHOLDER	2pcs=B <sub>1</sub> -139,40 mm* 2pcs=H-204,20 mm 2pcs=B <sub>2</sub> -49,80 mm* 2pcs=H-114,60 mm		
For frames :530 0010 , 530 0020 Sash :530 0110 , 530 0125			
MULLION	1pcs=H-61,00mm		
For frames :530 0010 , 530 0020			

ACCESSORIES		
MECHANICAL PUTTING	0423* 0365	4pcs 4pcs
ALIGNMENT ANGLE	14,1x1,2	4pcs
	5x1	8pcs
	Fuji2000	8pcs
DRAINAGE CAP	1601	8pcs
TWO - WAY MECHANISM		1set
OR HINGE HANDLE		2pcs
		1pcs
OR SCISSORS LATCH		2pcs
		1pcs

\*Only for 530 0020 , 530 0030 - 8pcs



CONGEST GASKET	
OUTER	2pcs=B 2pcs=H
INNER	2pcs=B 2pcs=H
CENTRAL	2pcs=B <sub>1</sub> 2pcs=H
GLASS OUTER	2pcs=B <sub>1</sub> -139mm* 2pcs=H-204mm 2pcs=B <sub>2</sub> -50mm* 2pcs=H-115mm
GLASS INNER	2pcs=B <sub>1</sub> -139mm* 2pcs=H-204mm 2pcs=B <sub>2</sub> -50mm* 2pcs=H-115mm

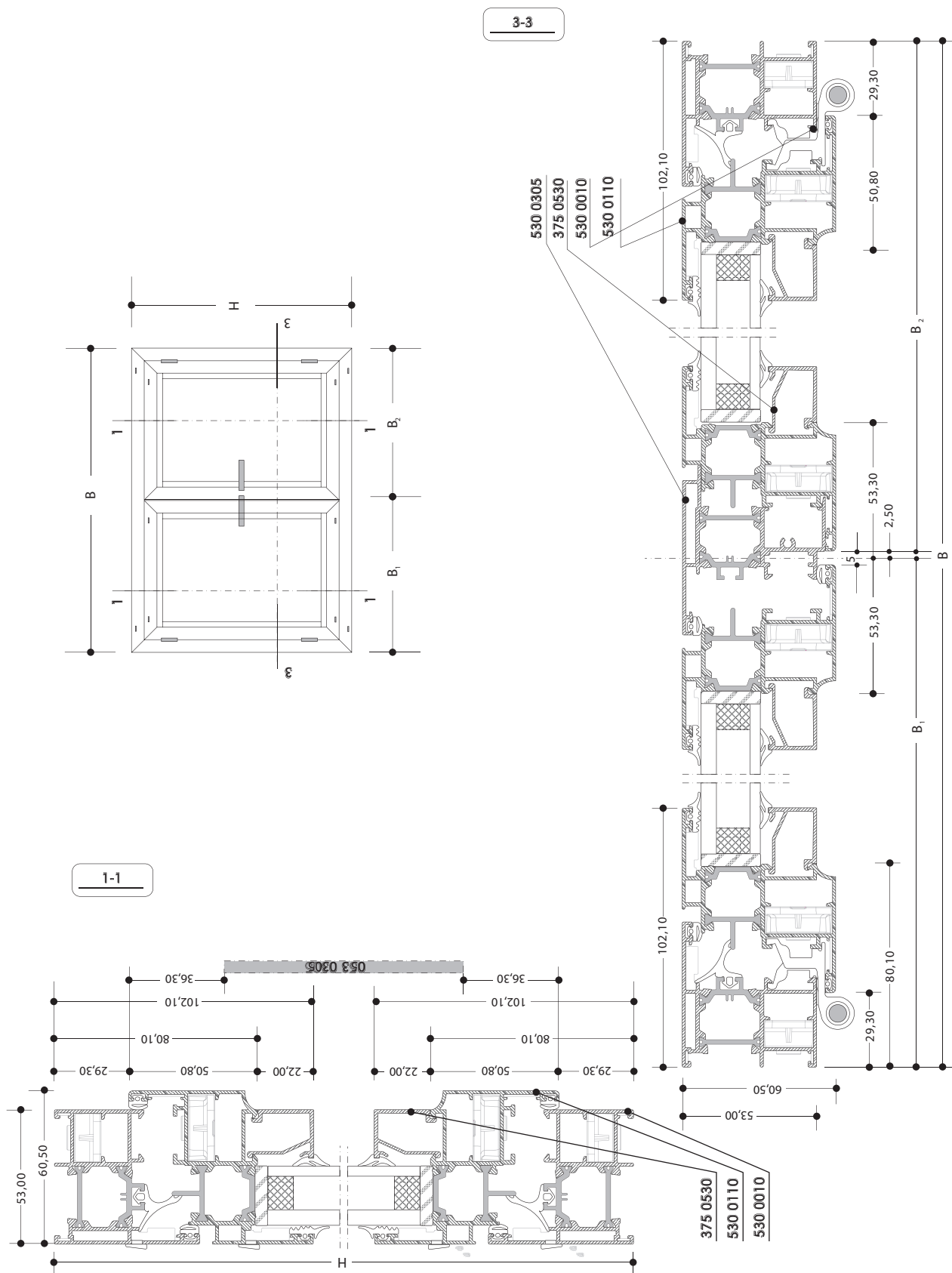

\*Only for mullion 530 0205

## SCHEME

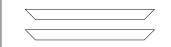
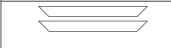
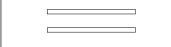

## SCHEME

PROFILES			
FRAME	2pcs=B		
	2pcs=H		
SASH	2pcs=B <sub>1</sub> -31,80 mm		
	2pcs=B <sub>2</sub> -31,80 mm		
	4pcs=H-58,60 mm		
For frames: 530 0010 , 530 0020			
GLASSHOLDER	2pcs=B <sub>1</sub> -133,40 mm*		
	4pcs=H-204,20 mm		
	2pcs=B <sub>2</sub> -133,40 mm*		
For frames: 530 0010 , 530 0020 Sash: 530 0110 , 530 0125			
OVERHUNG	1pcs=H-131,00mm		
For frames :530 0010 , 530 0020			

ACCESSORIES		
MECHANICAL PUTTING	0423*	4pcs
	0365	8pcs
ALIGNMENT ANGLE	14,1x1,2	8pcs
	5x1	8pcs
	Fuji2000	12pcs
DRAINAGE CAP	1601	12pcs
TWO - WAY MECHANISM		1set
HINGE HANDLE		2pcs
		1pcs
LATCH FOR TWO-WINGED		1set
CAP FOR TWO-WINGED		2pcs
OR HINGE HANDLE		4pcs
		2pcs
LATCH FOR TWO-WINGED		1set



CONGET GASKET	
OUTER	2pcs=B 2pcs=H
INNER	2pcs=B 2pcs=H
CENTRAL	2pcs=B <sub>1</sub> 2pcs=H 1pcs=H-131mm
GLASS OUTER	2pcs=B <sub>1</sub> -133mm 4pcs=H-204mm 2pcs=B <sub>2</sub> -133mm
GLASS INNER	2pcs=B <sub>1</sub> -133mm 4pcs=H-204mm 2pcs=B <sub>2</sub> -133mm

\*Only for 530 0020 , 530 0030 - 8pcs

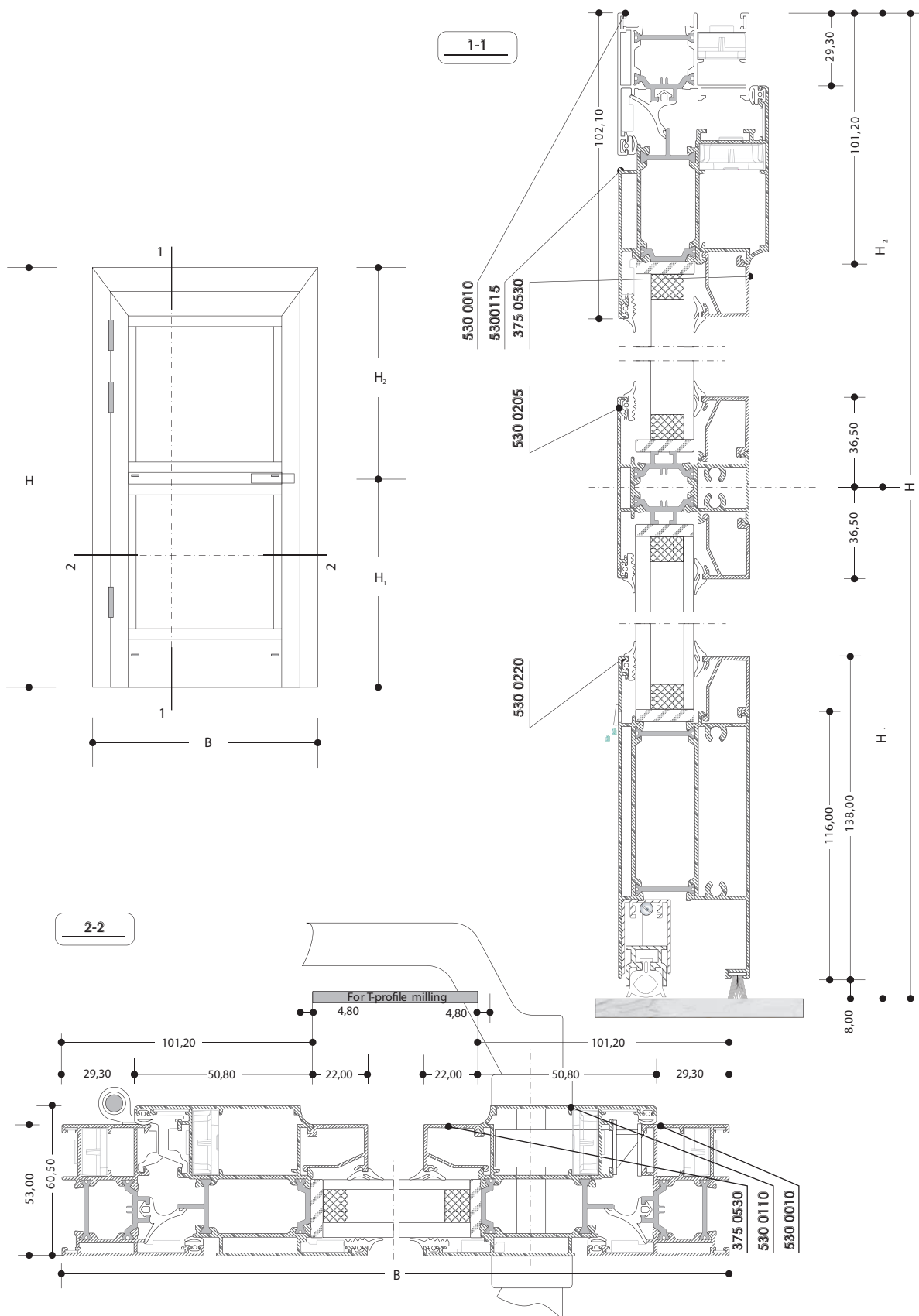
## SCHEME

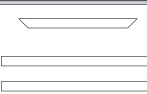
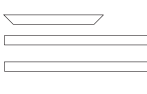
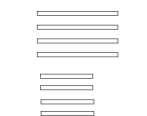

## SCHEME

PROFILES			
FRAME	1pcs=B 2pcs=H		
SASH	1pcs=B-58,60 mm 2pcs=H-37,30 mm		
For frames: 530 0010 , 530 0020			
GLASSHOLDER	4pcs=B-202,40 2pcs=H <sub>1</sub> -174,50 mm* 2pcs=H <sub>2</sub> -159,70 mm		
For frames: 530 0010 , 530 0020 Sash: 530 0115 , 530 0130 , 530 0135			
MULLION	1pcs=B-192,80mm		
For frames: 530 0010 , 530 0020 Sash: 530 0115 , 530 0130 , 530 0135			
BOARD FOR DOOR	1pcs=B-192,80mm		
For frames: 530 0010 , 530 0020 Sash: 530 0115 , 530 0130 , 530 0135			

\*- only for mullion 530 0205

ACCESSORIES		
MECHANICAL PUTTING	0423* 0365	2pcs 2pcs
ALIGNMENT ANGLE	14,1x1,2 5x1 Fuji2000	2pcs 4pcs 4pcs
DRAINAGE CAP	1601	4pcs
CONGEST SYSTEM		1pcs
HINGE HANDLE		3pcs 1set
HANDLE 35mm PATRON OPPOSITER		1set

\* Only for 530 0020 , 530 0030 - 8pcs

CONGEST GASKET	
OUTER	2pcs=B 2pcs=H
INNER	2pcs=B 2pcs=H
CENTRAL	1pcs =B 2pcs=H
GLASS OUTER	4pcs=B-202mm 2pcs=H <sub>1</sub> -175mm* 2pcs=H <sub>2</sub> -160mm*
GLASS INNER	4pcs=B-202mm 2pcs=H <sub>1</sub> -175mm* 2pcs=H <sub>2</sub> -160mm*
BRUSH-8mm	1pcs=H <sub>2</sub> -58mm

\*- only for mullion 530 0205

## **SCHEME**

# Three dimensions details

## 3D DETAILS

### MECHANICAL PUTTING AND ALIGNMENT ANGLES FOR LITTLE FRAME

Fuji2000

Add. putting

0423

5x1

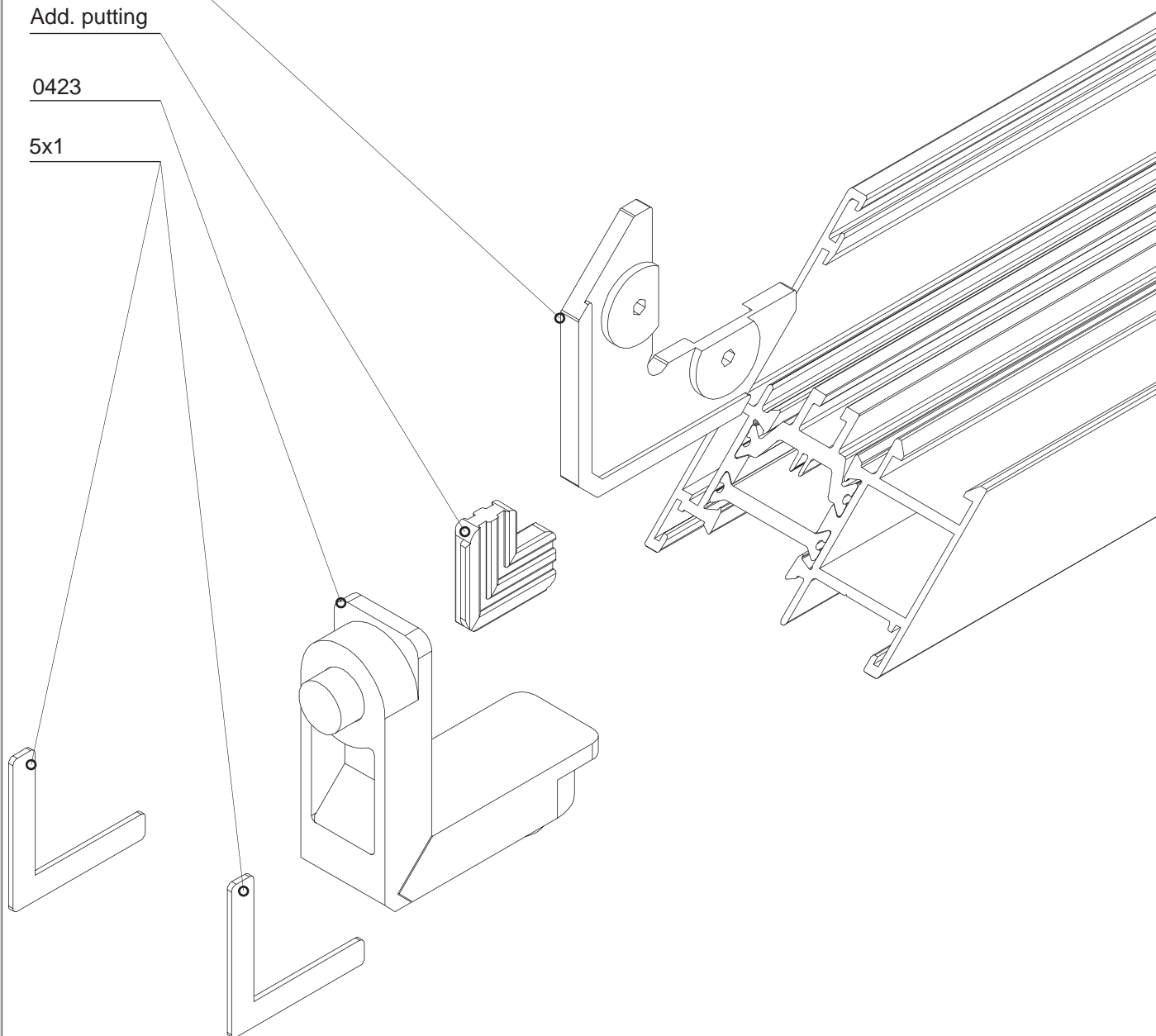

## 3D DETAILS

### PRESS PUTTING AND ALIGNMENT ANGLES FOR LITTLE FRAME

Fuji2000

Add. putting

10,5x19,0

5x1

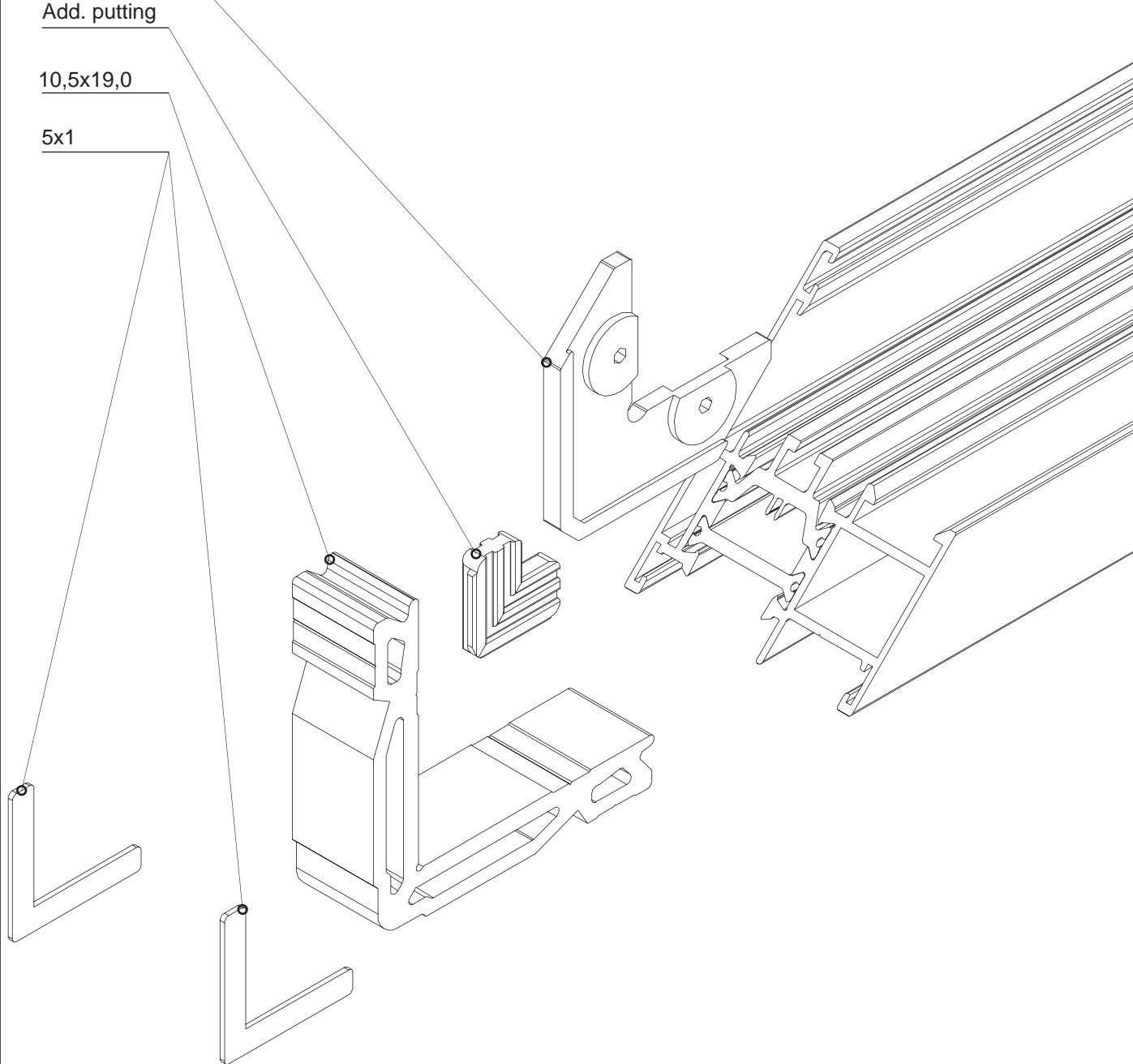

## 3D DETAILS

MECHANICAL PUTTING + ADDITION AND ALIGNMENT ANGLES FOR BIG FRAME

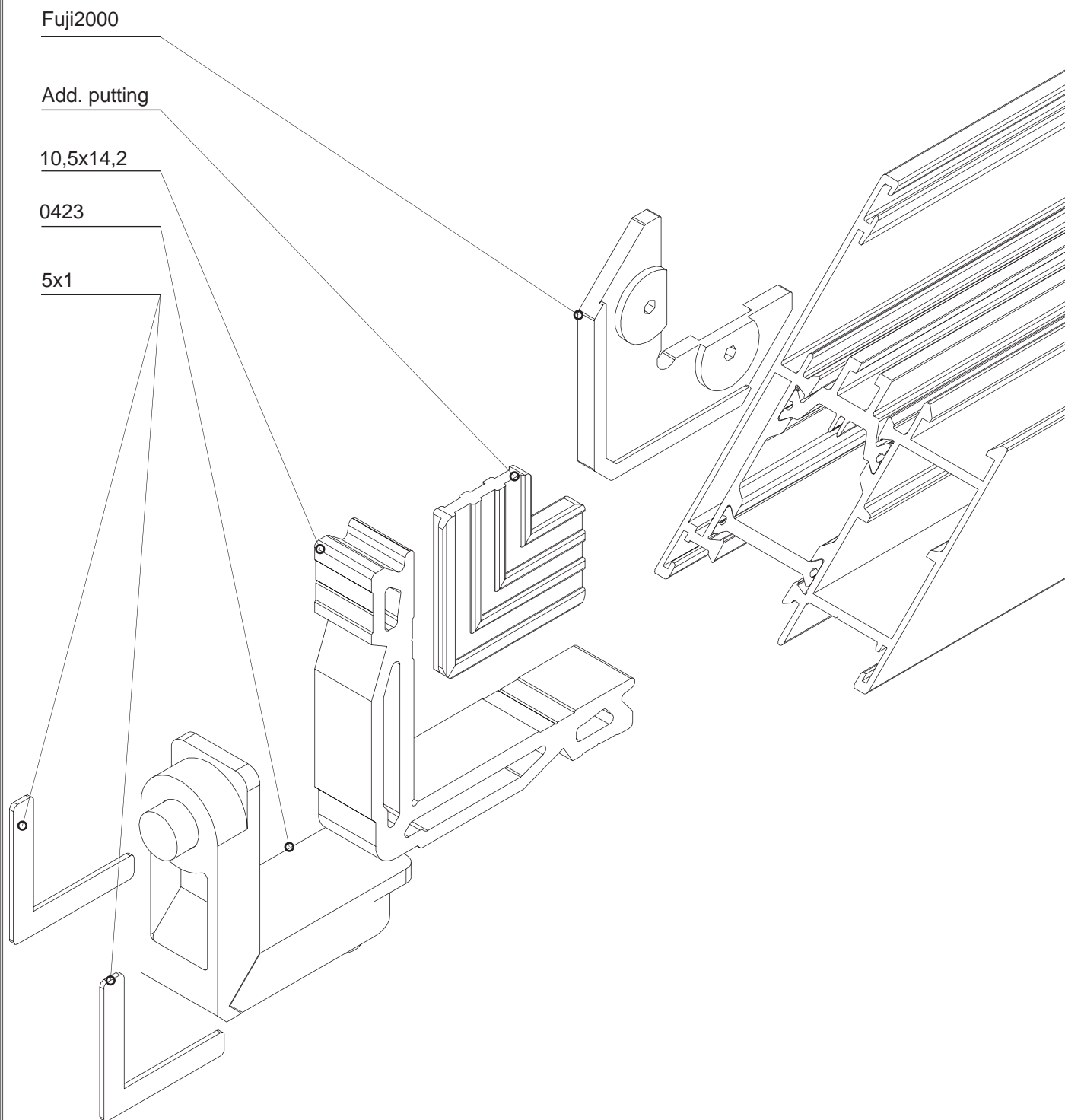

## 3D DETAILS

PRESS PUTTING AND ALIGNMENT ANGLES FOR BIG FRAME

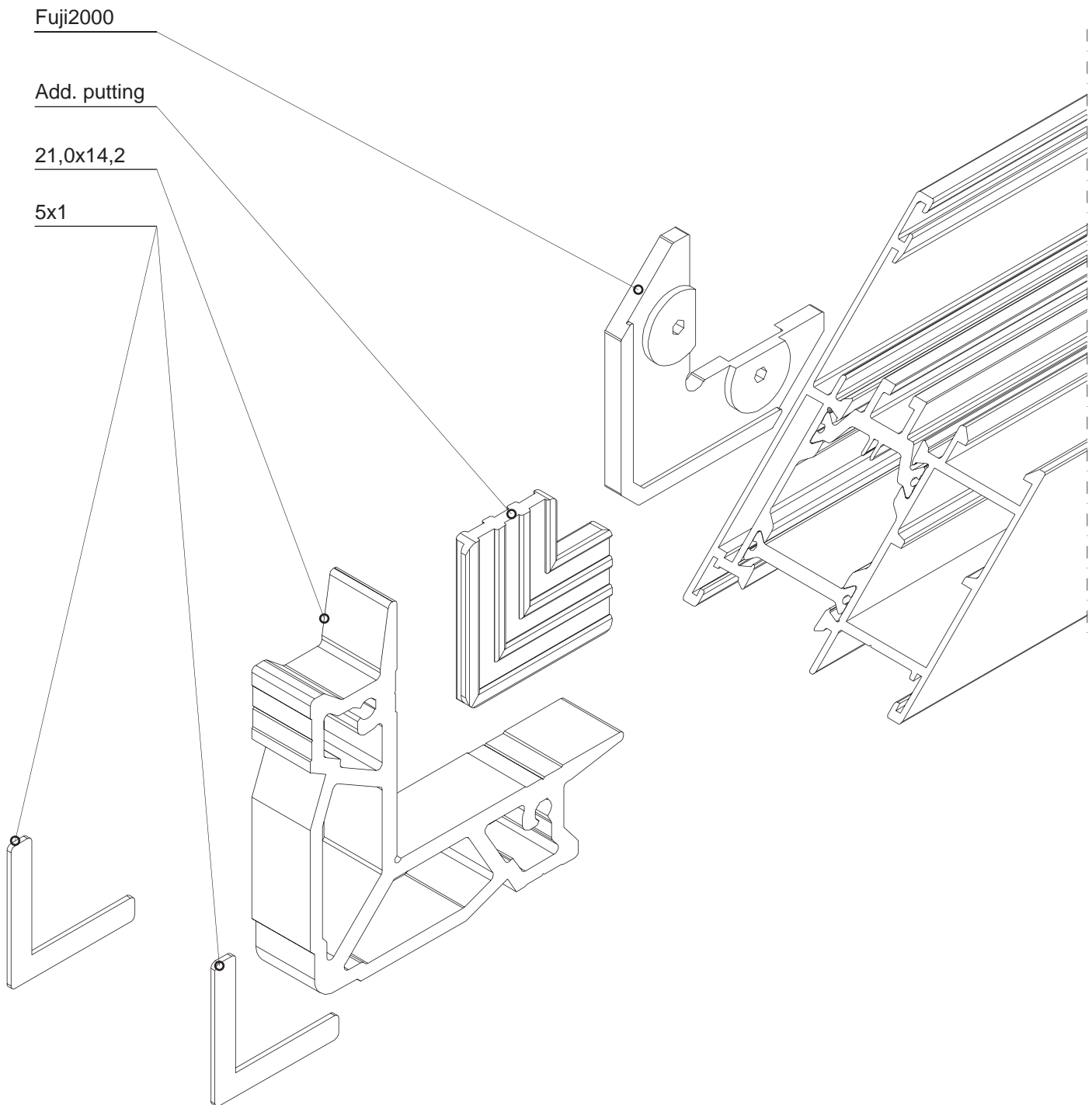

## 3D DETAILS

MECHANICAL PUTTING AND ALIGNMENT ANGLES FOR LITTLE SASH

Fuji2000

0365S

14,1x1,2

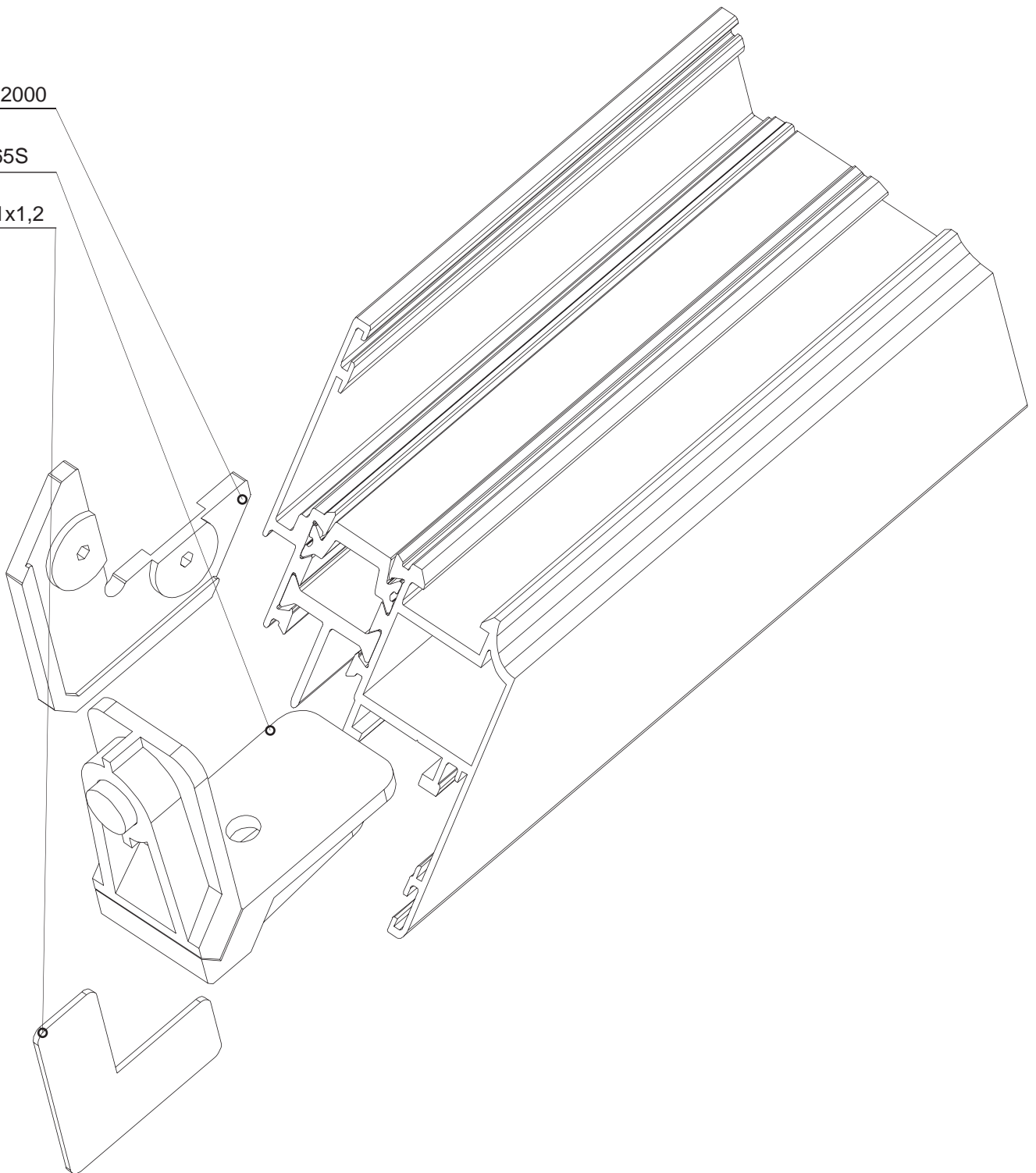

## 3D DETAILS

PRESS PUTTING AND ALIGNMENT ANGLES FOR LITTLE SASH

Fuji2000

10,5x26,2

14,1x1,2

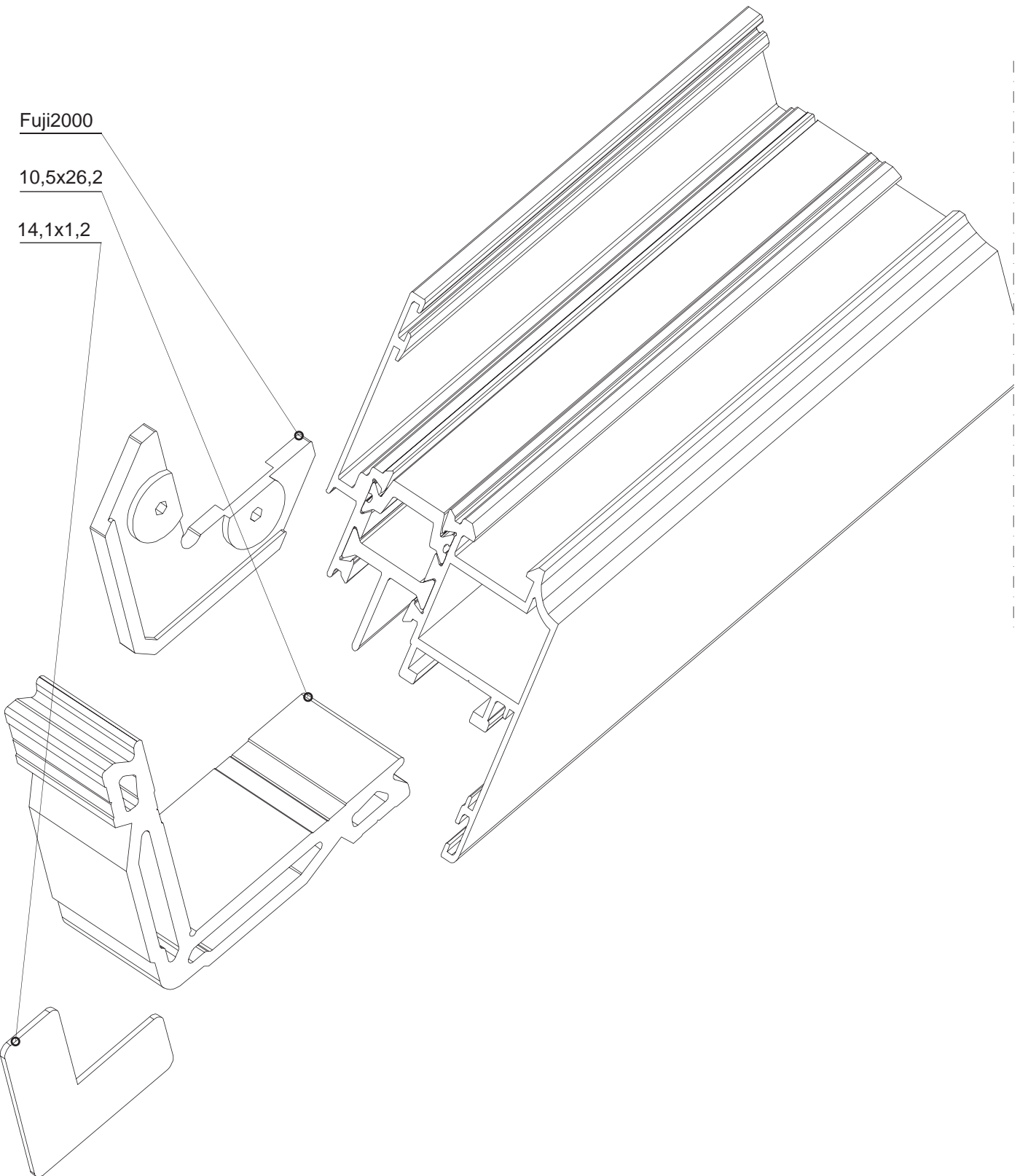

## 3D DETAILS

MECHANICAL PUTTING + ADDITION AND ALIGNMENT ANGLES FOR MIDDLE SASH

Fuji2000

Add. putting

10,5x19,0

0365S

14,1x1,2

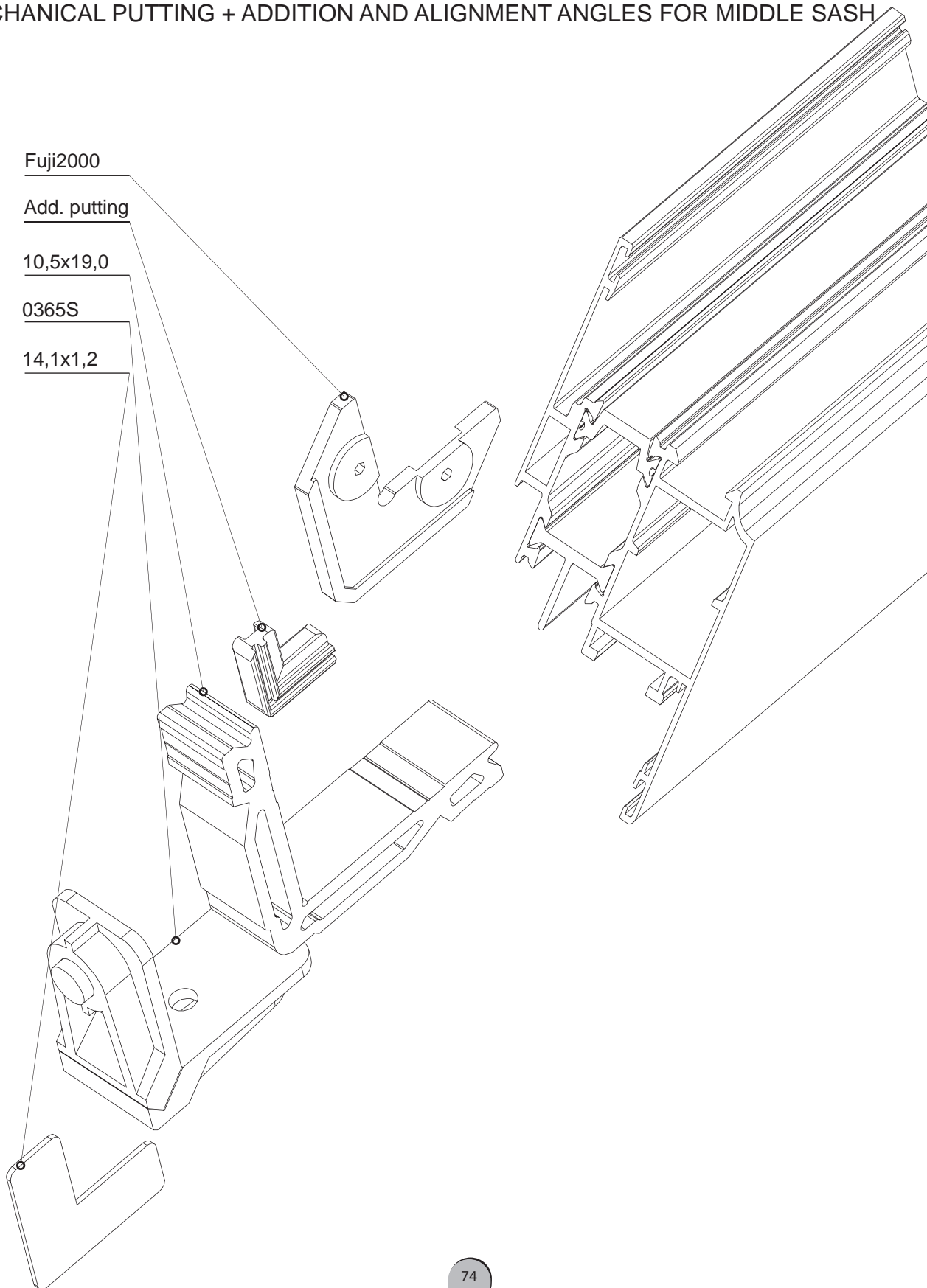

## 3D DETAILS

### PRESS PUTTING AND ALIGNMENT ANGLES FOR MIDDLE SASH

Fuji2000

Add. putting

21,0x21,4

14,1x1,2

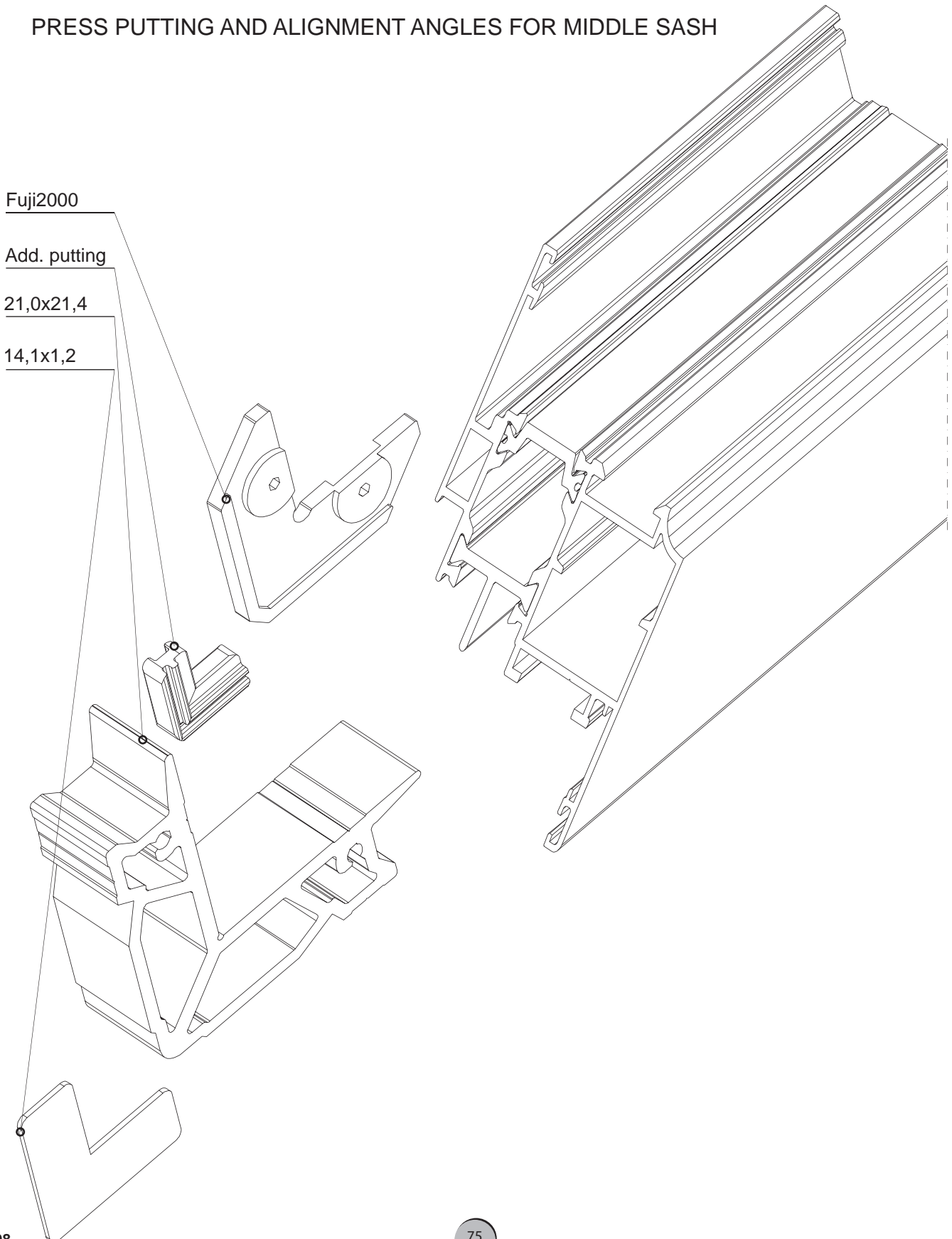

## 3D DETAILS

MECH. PUTTING + ADDITION AND ALIGNMENT ANGLES FOR BIG SASH

Fuji2000

Add. putting

31,5x21,4

0365S

14,1x1,2

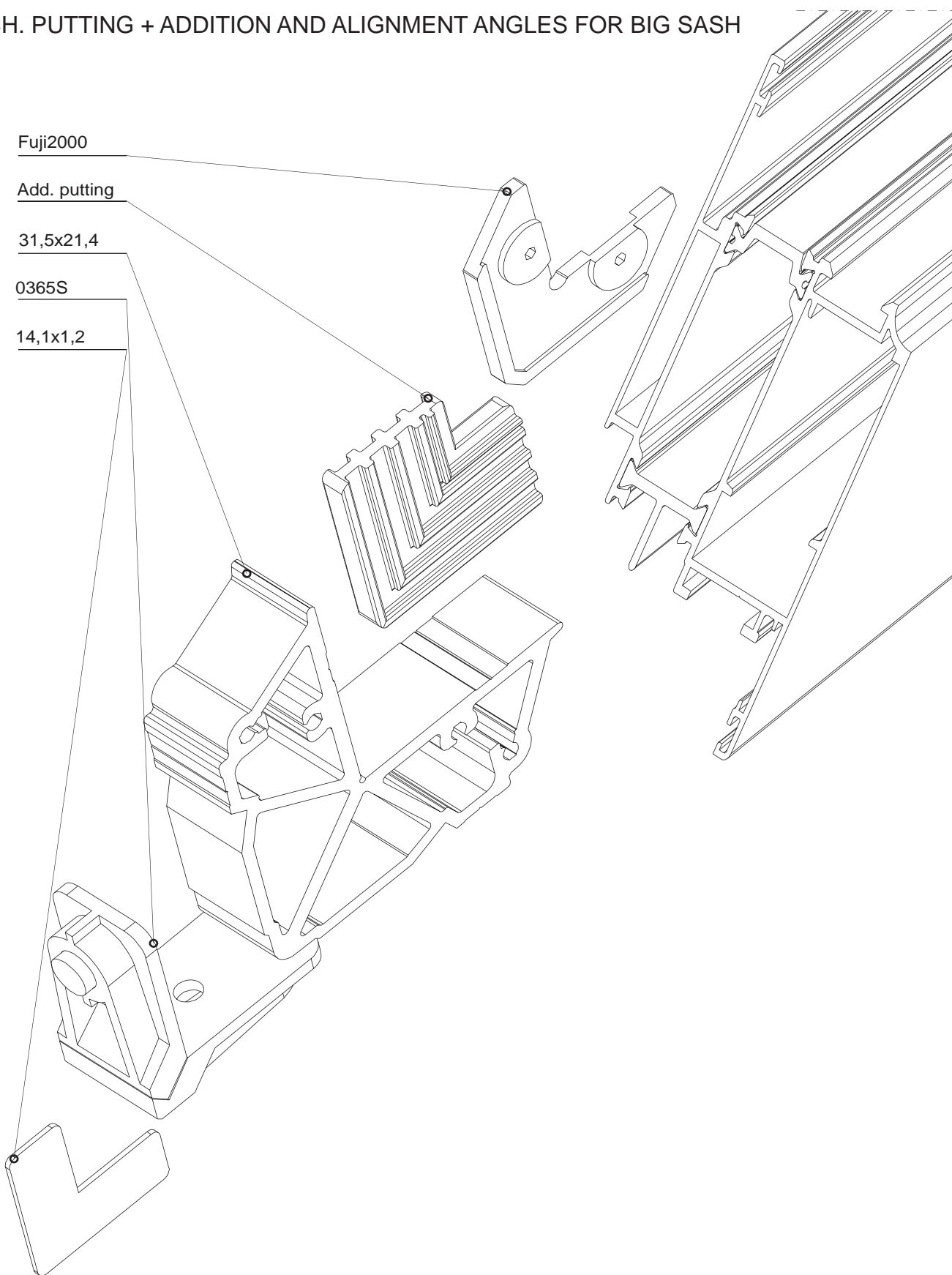

## 3D DETAILS

PRESS PUTTING AND ALIGNMENT ANGLES FOR BIG SASH

Fuji2000

Add. putting

42,0x21,4

14,1x1,2

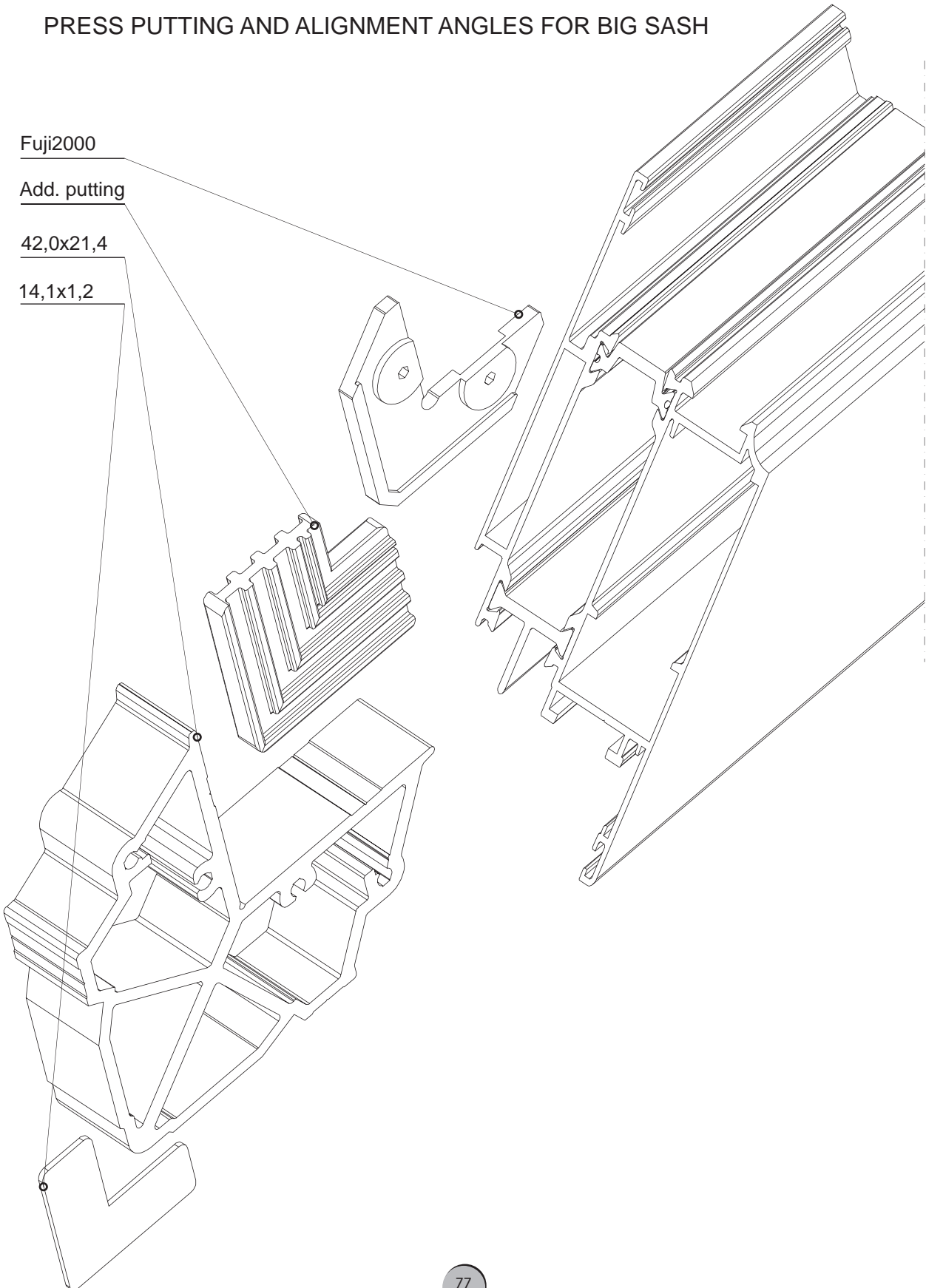

## 3D DETAILS

HANDLE FOR WINDOW

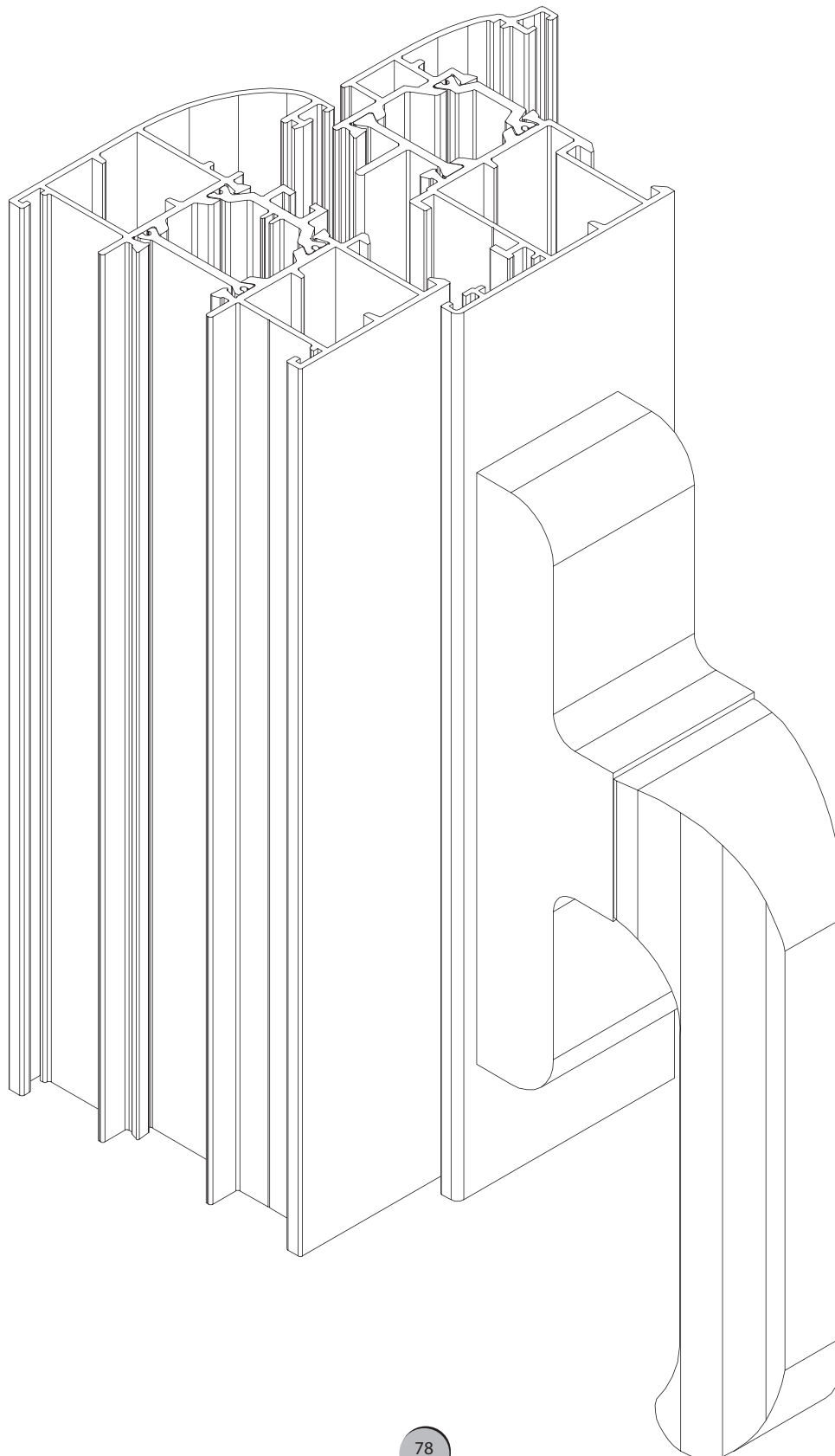

## 3D DETAILS

LATCH FOR WINDOW

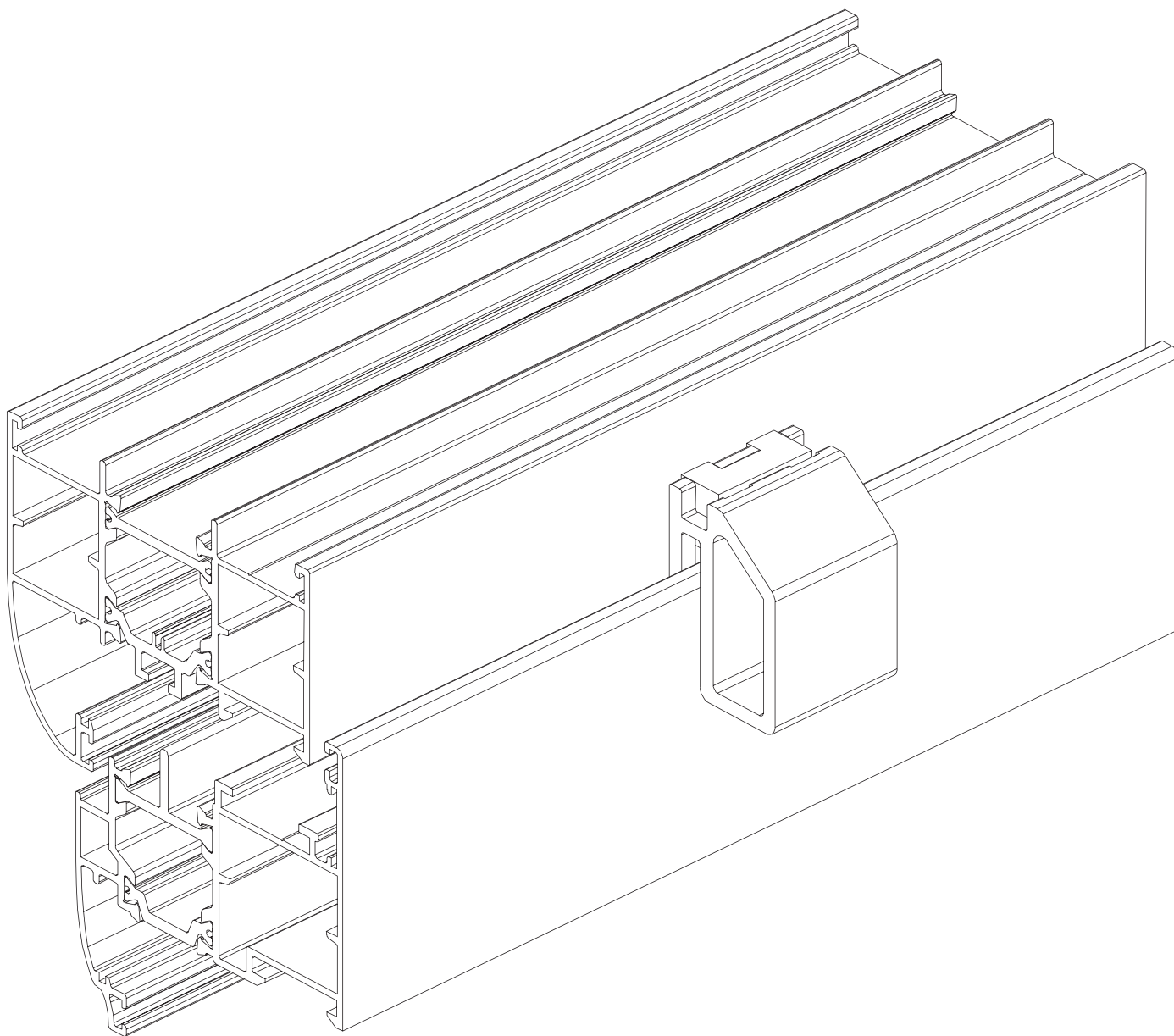

## 3D DETAILS

HINGES-"EURO-CAMERA"

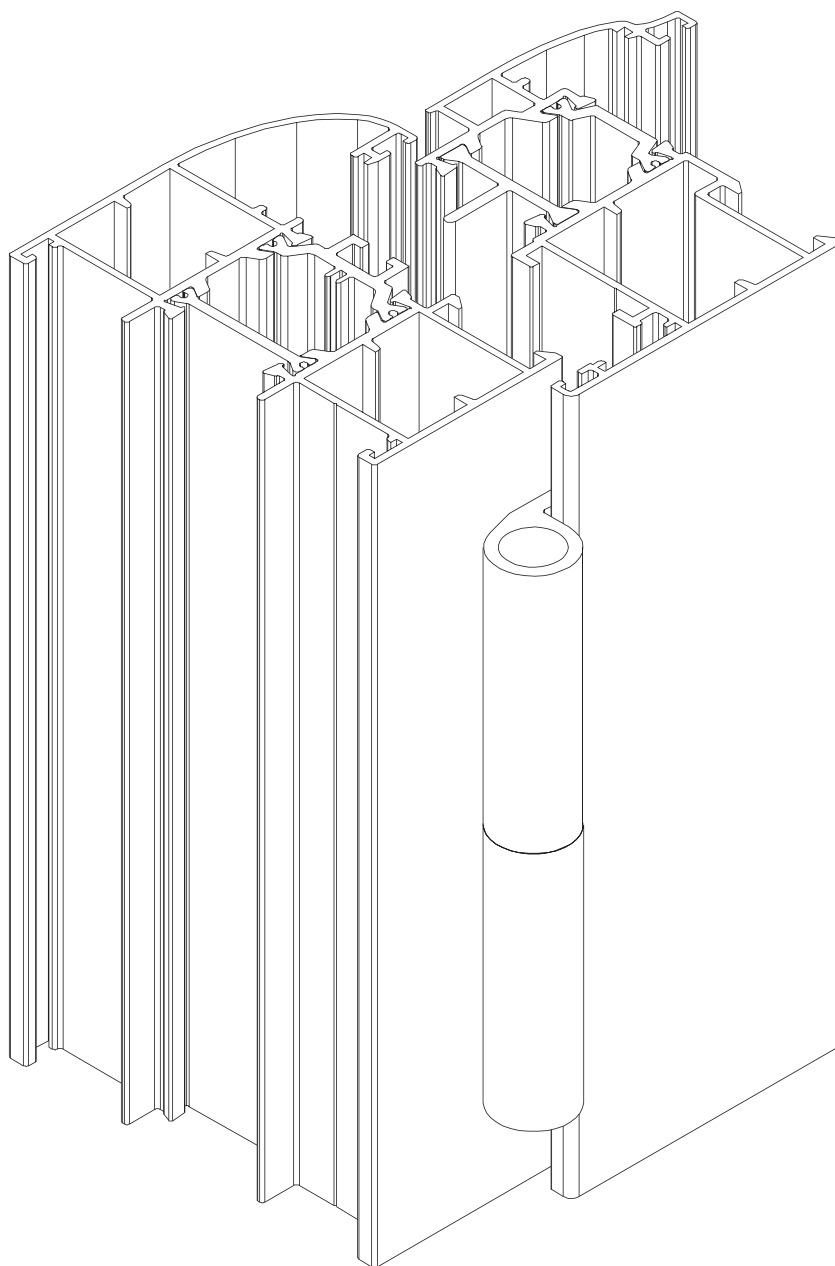

## 3D DETAILS

MILL MACHINE FOR MILLING OF MULLIONS

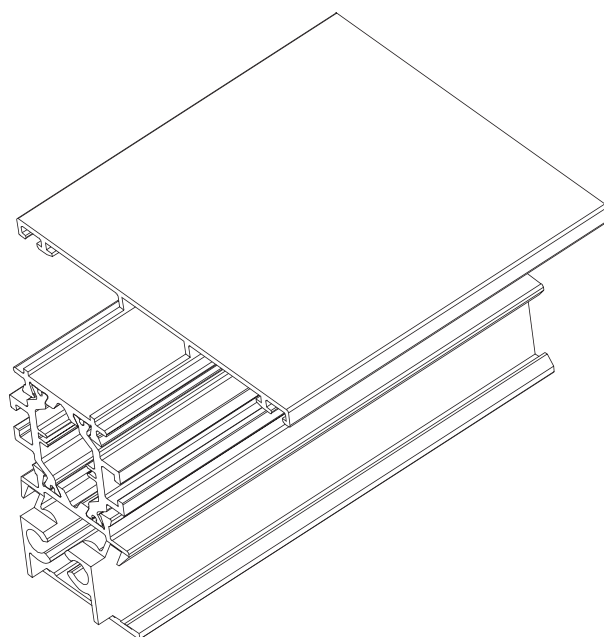
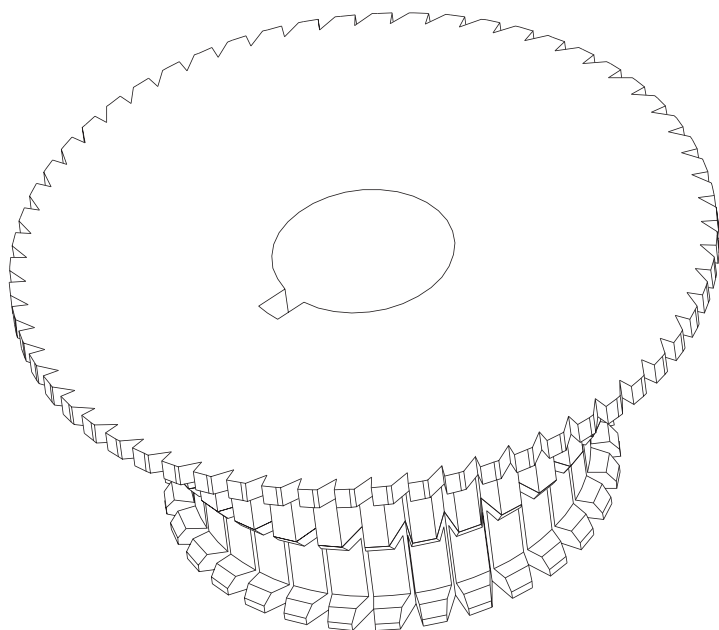

## 3D DETAILS

### PLASTIC DREINAGE CAPS

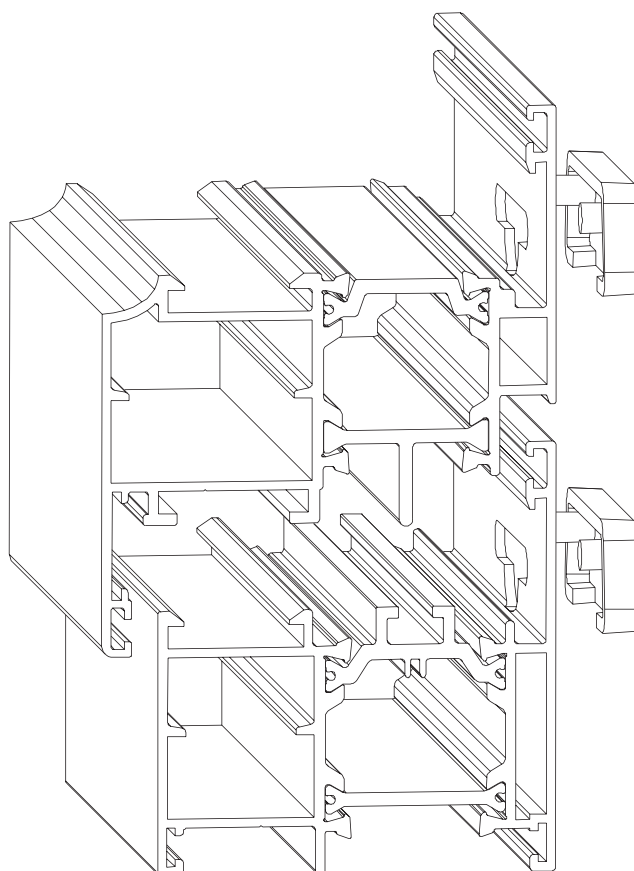

Scheme of drainage canals

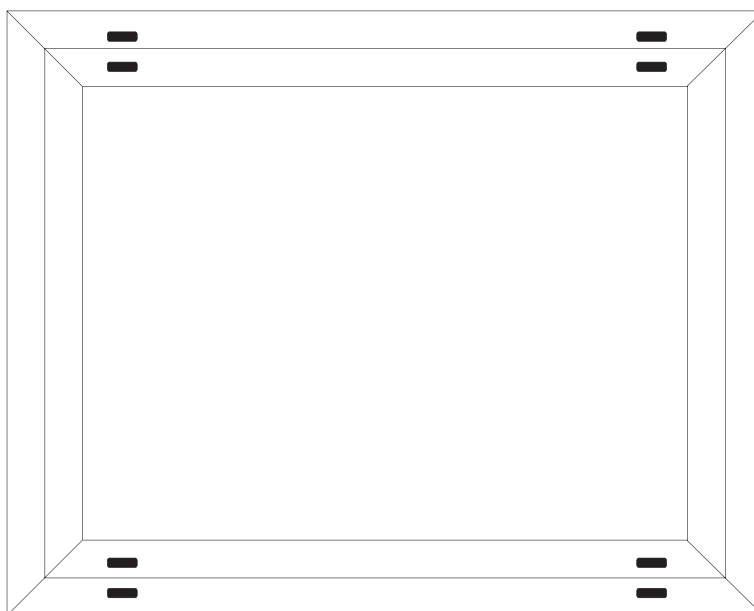

## 3D DETAILS

CAP FOR ADDITION ON TWO-WINGS OPPENING

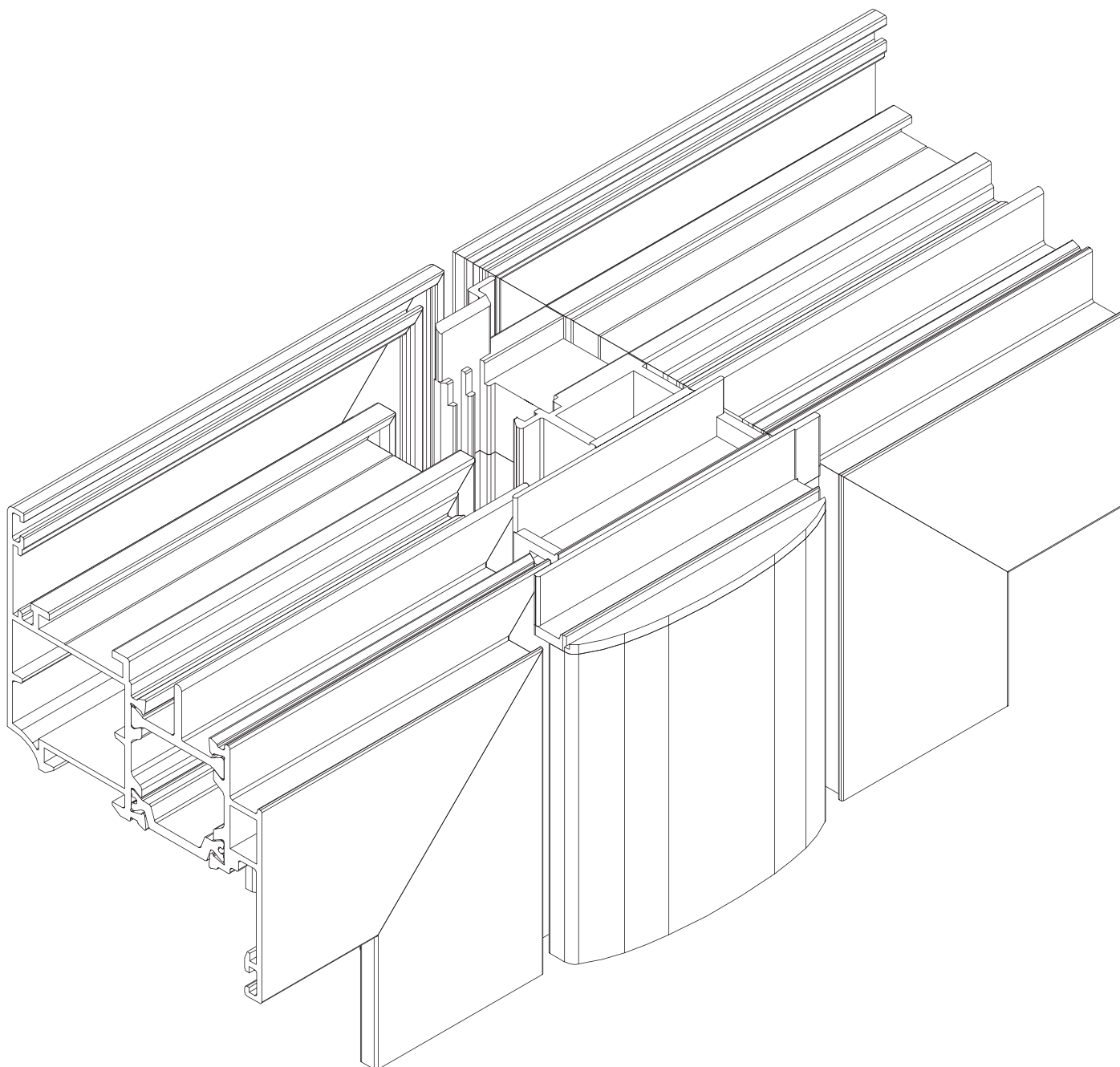



## 3D DETAILS

LOCK - 35 mm, PATRON, OPPOSITER AND HANDLE FOR DOOR

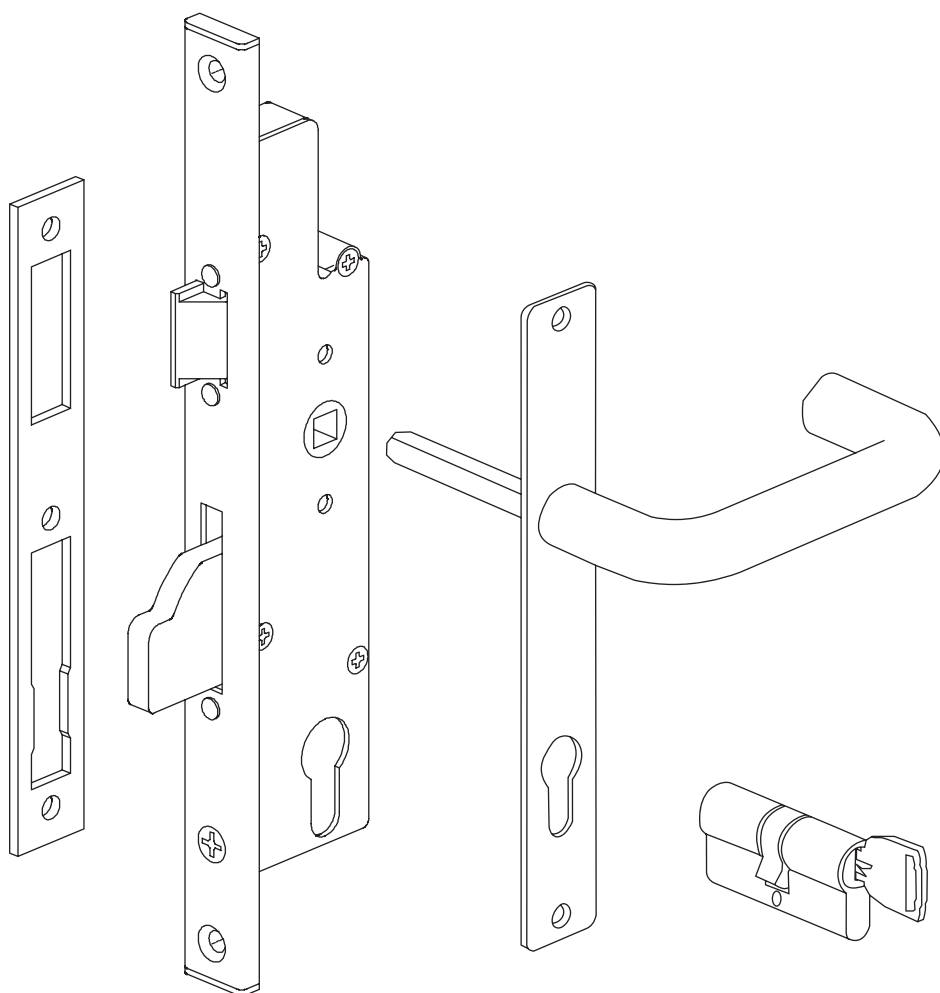

## PUTTING

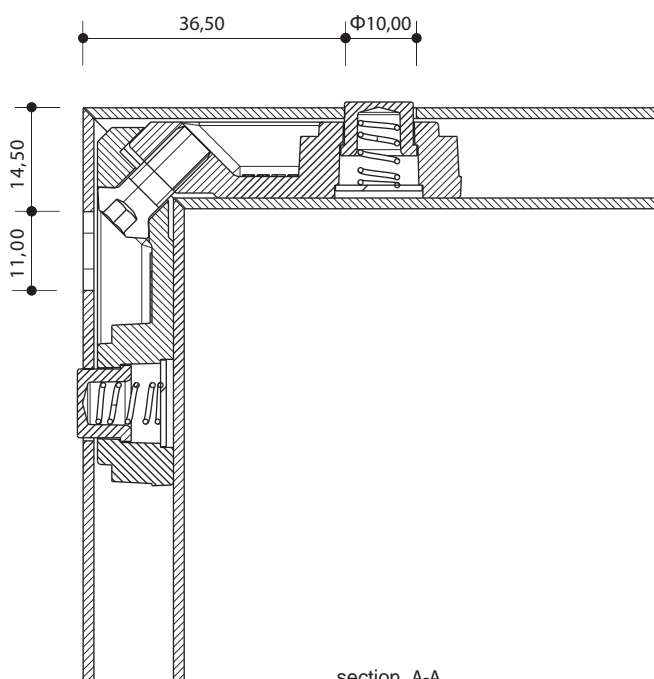
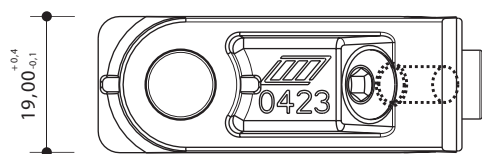
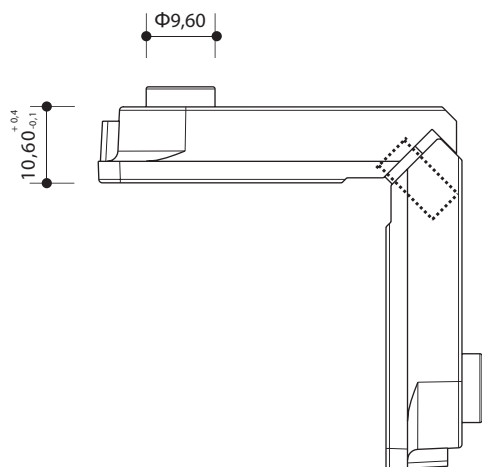

section A-A

0423

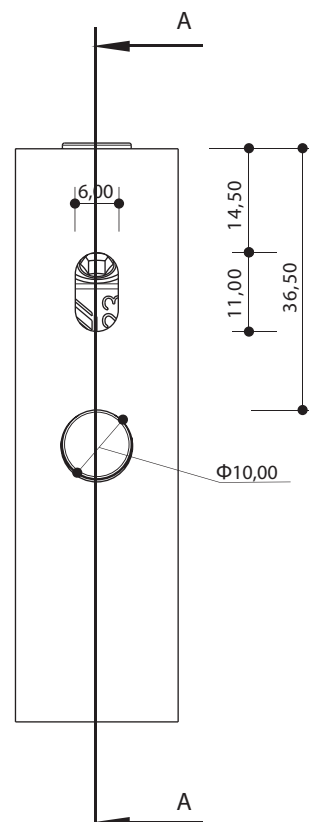
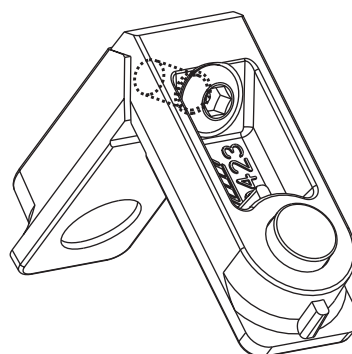
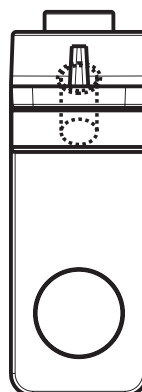

## PUTTING

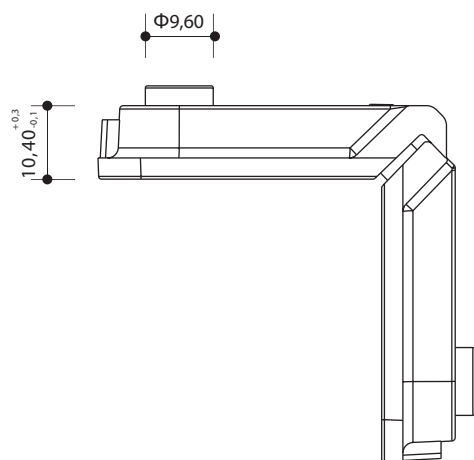

0365S

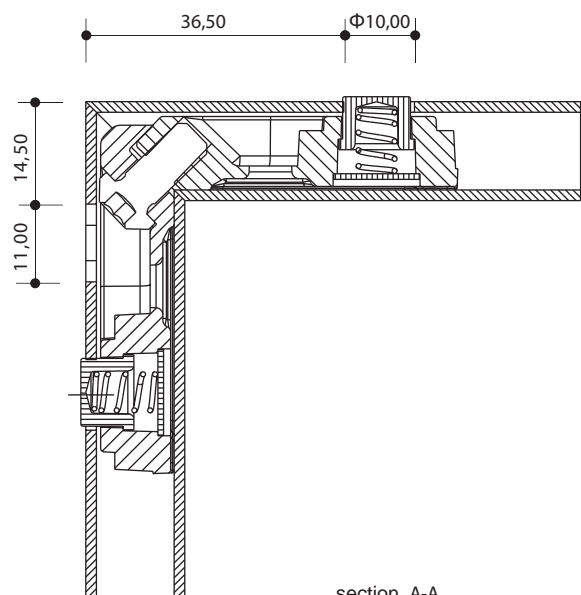
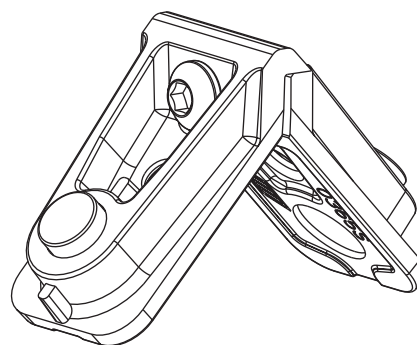
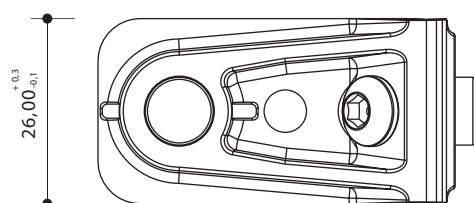
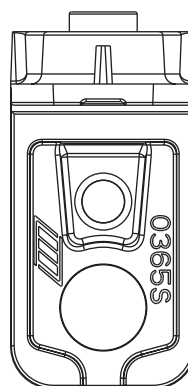

section A-A

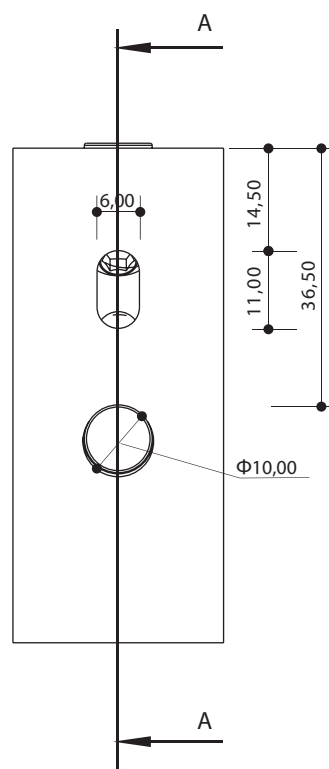

## PUTTING

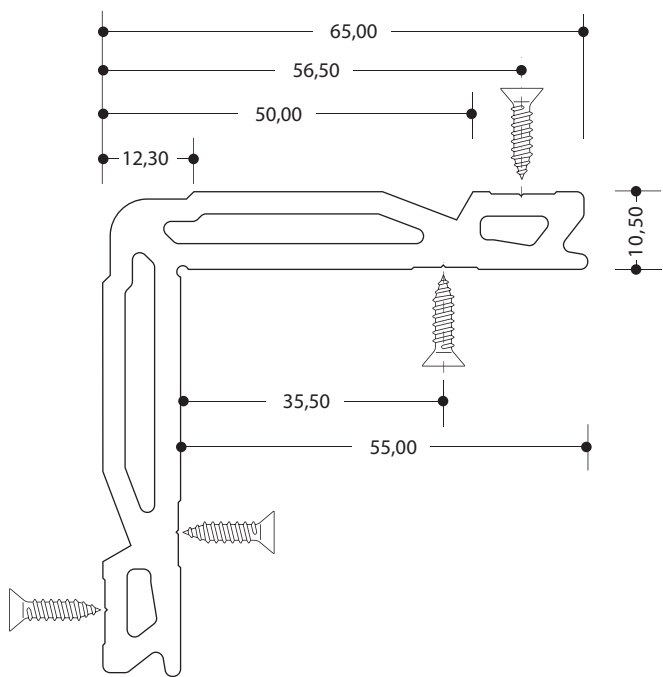

10,5x14,2

10,5x19,0

10,5x26,2

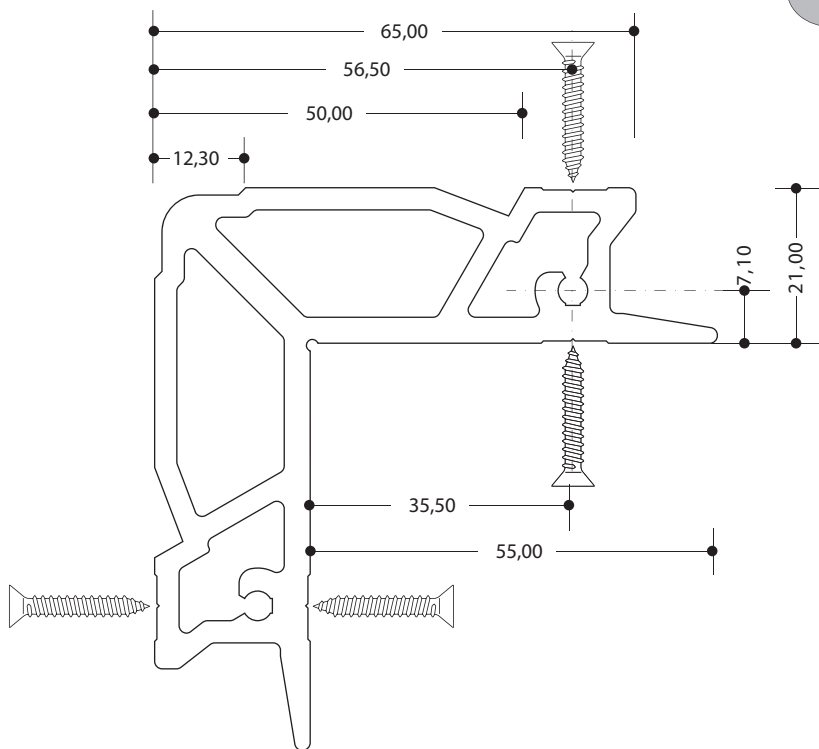
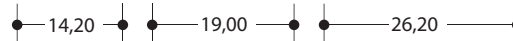
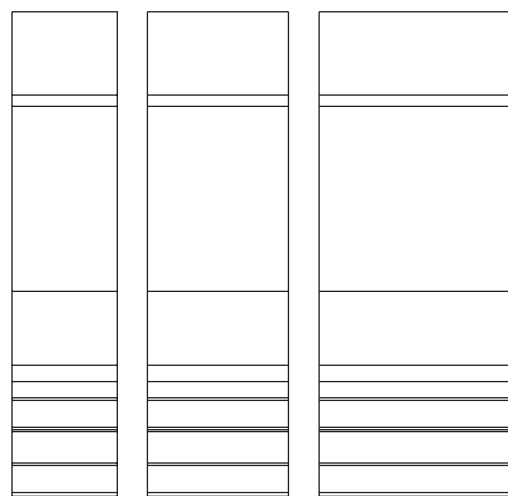

21,0x14,2

21,0x21,4

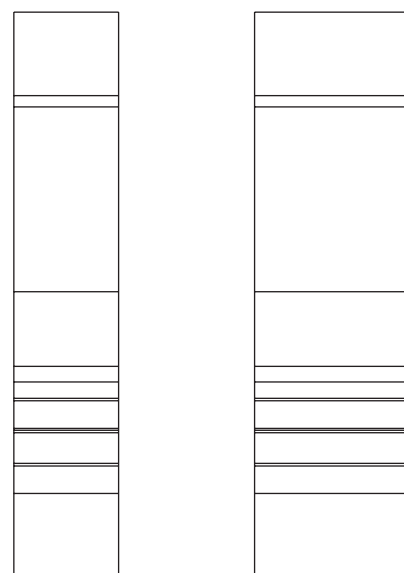

## PUTTING

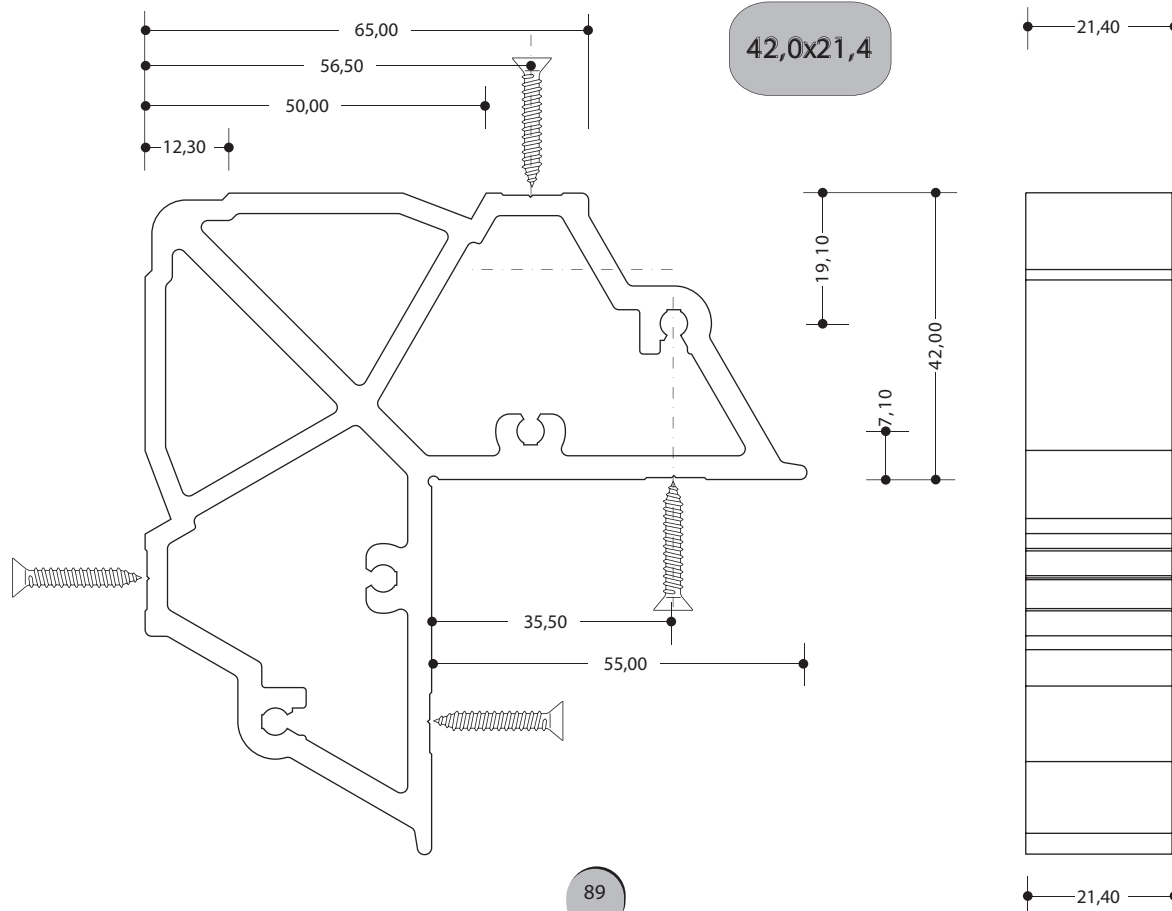
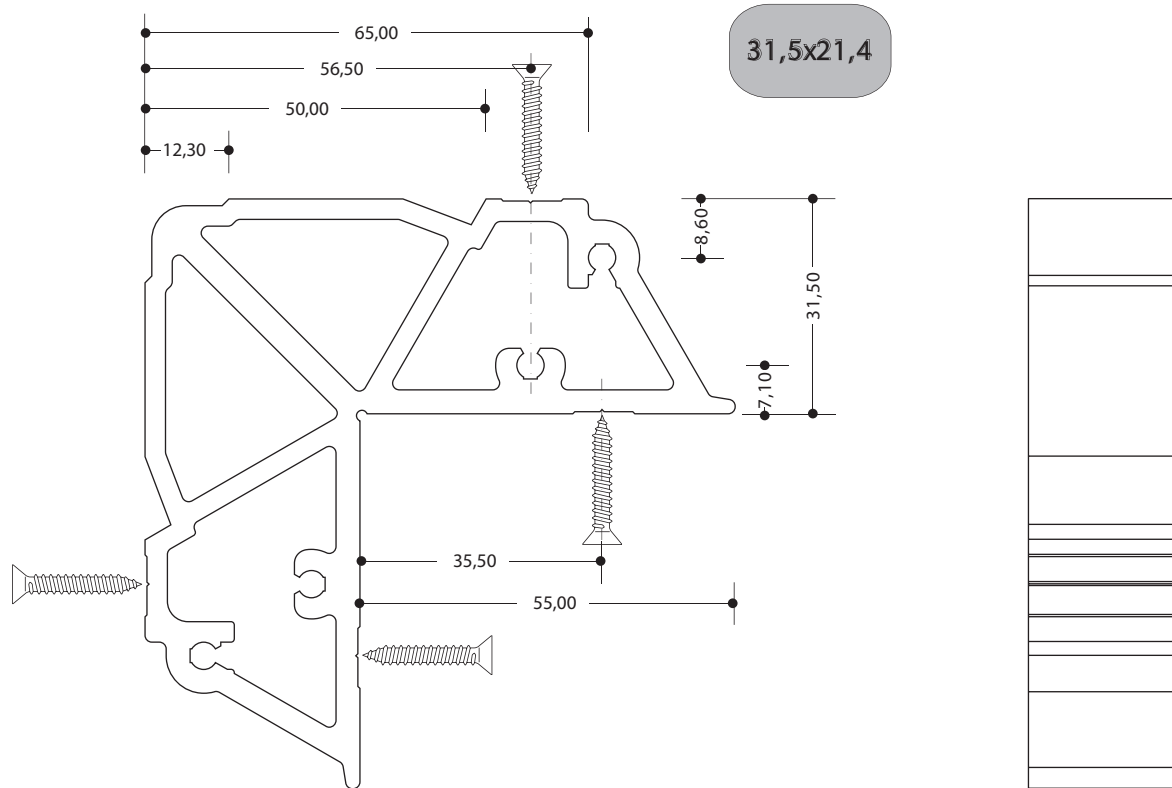

## PUTTING

Fuji2000

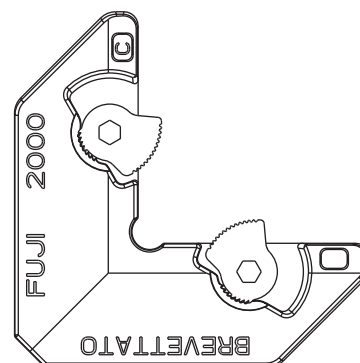
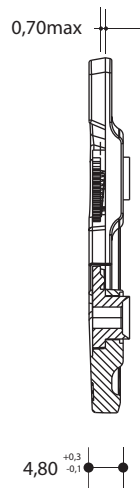
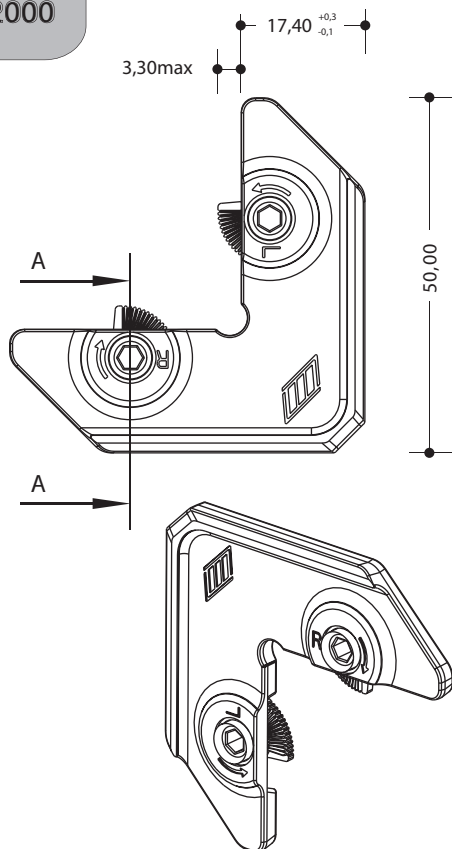

Recommendation - angle FUJI 2000 production of company "Monticelli"

5x1

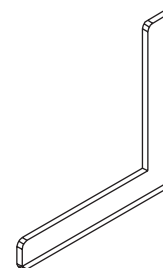
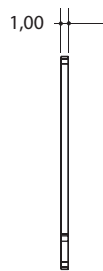
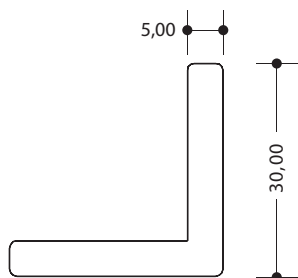
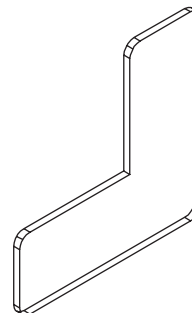
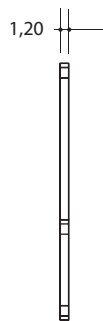
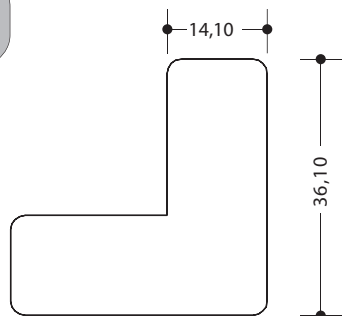

## PUTTING

PLASTIC ADDITIONAL PUTTING FOR LITTLE FRAMES

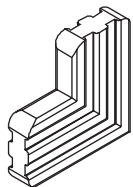

PLASTIC ADDITIONAL PUTTING FOR BIG FRAMES

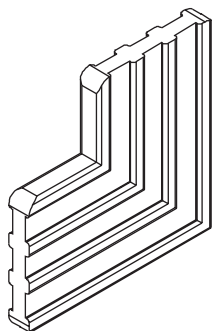

PLASTIC ADDITIONAL PUTTING FOR MIDDLE SASHES

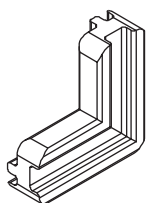

PLASTIC ADDITIONAL PUTTING FOR BIG SASHES

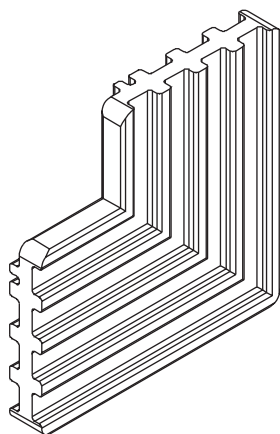

## CONGEST GASKETS

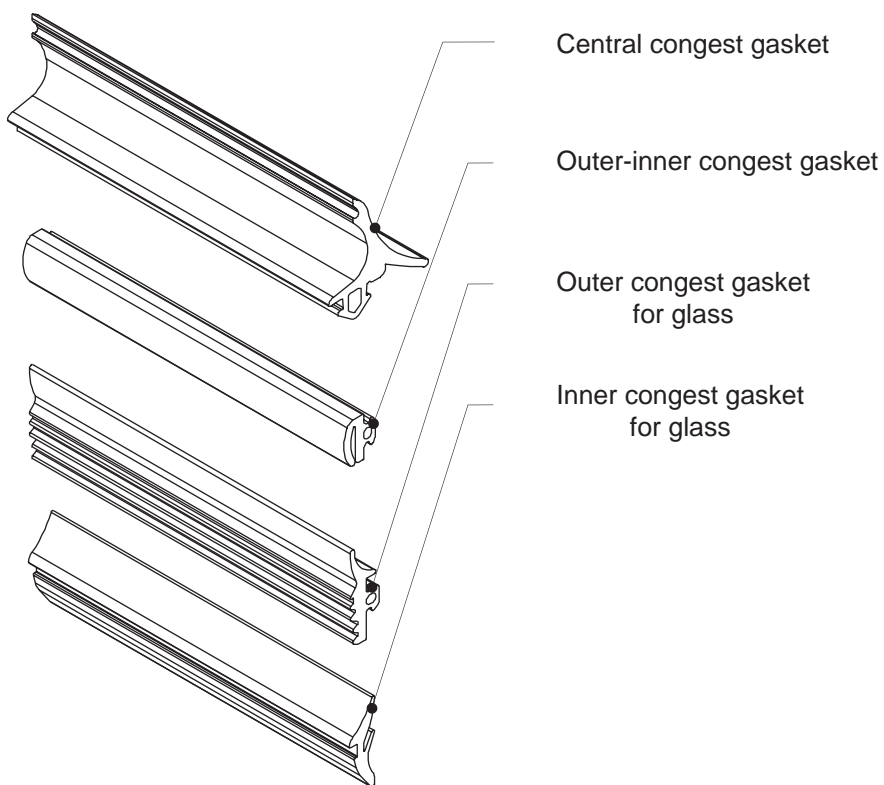

## THERMAL ANALYSIS

U - factor for 530 ≈ 2,37-2,86 (W/m<sup>2</sup>-K)

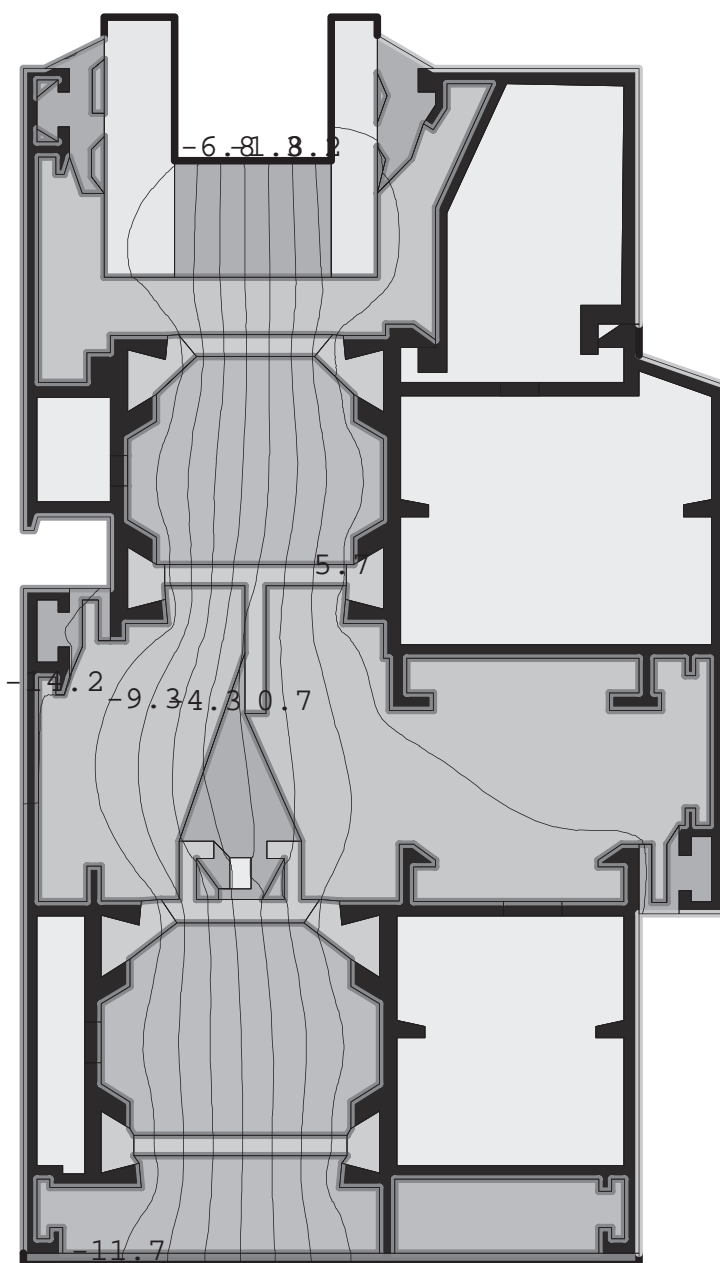

## NOTES

---

---

---

---

---

---

---

---

---

---



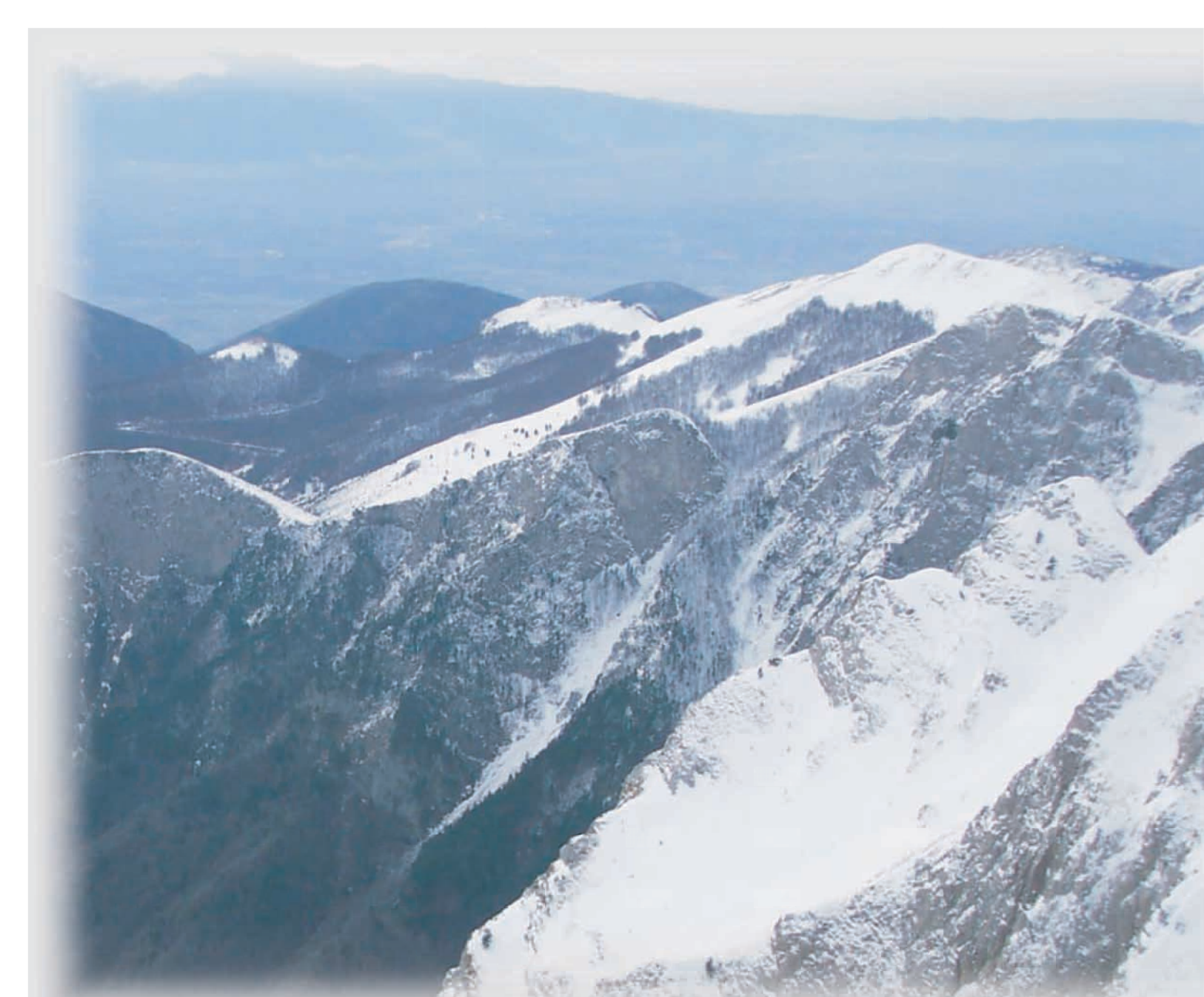

# ALTEST LTD

Bulgaria, Bourgas 8000  
phone: 00359/56/88 04 40

fax: 00359/56/88 04 43  
e-mail: [altest@infotel.bg](mailto:altest@infotel.bg)

[www.altest-kmg.com](http://www.altest-kmg.com)