

375 PONY

aluminium profiles system

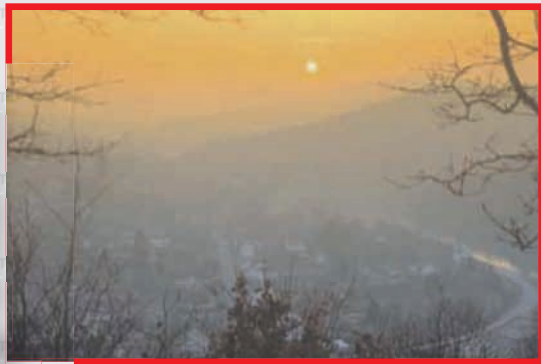

ATTENTION!

For faultless operation, please read carefully this catalogue!

It was elaborated by ALTEST Company. Its copying, reproduction and reprinting without our consent is not welcomed!

The profiles presented in the catalogue are patented and ALTEST Company has the exclusive rights.

ALTEST Company reserves the right to modify the profiles and the presented sections at its own discretion. The system is equipped with full set of calculations made in accordance with the existing manufacturing requirements, presented in this catalogue.

In conclusion – use original ALTEST profiles in compliance with the peculiarities and the technical characteristics presented in this catalogue.

CONTENTS

1. INTRODUCTION	5
2. REVIEW OF PROFILES	6
3. PROFILES	11
4. GLASSPACKETS	32
5. SECTIONS	34
6. SECTIONAL DRAWINGS	37
7. SCHEMES	71
8. THREE DIMENSIONS DETAILS	87
9. PUTTING	108
10. ALIGNMENT ANGLES	111
11. CONGEST GASKET	112
12. THERMAL ANALYSIS	113
13. NOTES	114

375 0540
GLASSHOLDER

GASKET
FOR GLASS

375 0125
SASH

CENTRAL
GASKET

375 0020
FRAME



INTRODUCTION

The "375 PONY" of company ALTEST is 37,5 mm aluminium series invented according to European standard and conformable to requirements and dimensions of the hardware – hinges, locks and etc. The system consists of wide composition of profiles suitable for any kind of solutions. It is design to fulfil exterior and interior architectural suggestions whenever thermal break is required.

The system "375 PONY" is suitable for different version of opening and fixed systems. The plentiful range of profiles, modern accessories and gaskets of EPDM guarantee the perfect draining and faultless performance in different situations. The series is suitable also for tilt and turn mechanism. Versions of fixed, vertical and horizontal opening windows as well as fixed and opening sections doors are practicable.

The system "375 PONY" is based on work with 3 seal gaskets - central, outer and inner (the central gasket is specially design for the series). The dimensions of the profiles channel are conformable to the European Standard and in this way provide trouble-free use of hardware and connecting joints. It can be equipped with accessories from the companies: Monticelli, Giesse, Lavaal, Comunello, Roto, Savio, Fapim and etc.

The plentiful range basic profiles (frames) and glass holders, allows the usage of single (4-10)mm pane and 24mm glazing.













Of course variable design elaborations are possible, due to wide variety of frames, sashes and other auxiliary profiles.



The profiles can be painted in all range of RAL colors.



According DIN 1725 T1 the aluminum used for production of aluminium profiles is AlMgSi0,5 F22.





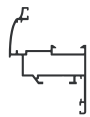
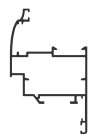
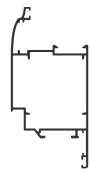
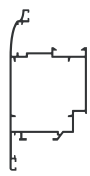
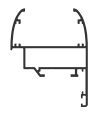
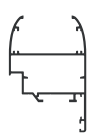
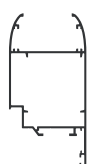

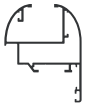
The technical and mechanical characteristics of the particular alloy are:

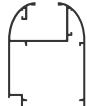
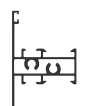
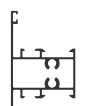
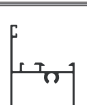
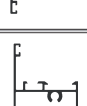
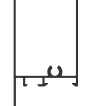
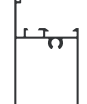

Elasticity module	:	70 000 Nmm-2
Coefficient of linear expansion	:	$\alpha = 2.34 \cdot 10^{-6} \text{ K}^{-1}$
Tensile strength	:	$R_m = 215 \text{ Nmm}^{-2}$
Relative density	:	$\gamma = 2.7 \text{ gr.cm}^{-3}$

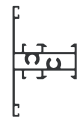
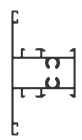
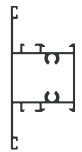
DRAWING	CODE	REL. WEIGHT,(gr/m)	INNERT. MOMENTS I_x/I_y (cm ⁴)	DIMENSIONS X/Y(mm)
	375 0005	580	2,88/4,22	37,50/46,80
	375 0010	663	5,55/5,24	37,50/57,20
	375 0015	640	3,20/5,43	45,00/46,80
	375 0020	664	3,31/6,20	45,00/46,80
	375 0025	821	7,24/7,57	45,00/57,20
	375 0030	725	6,59/6,45	45,00/57,20
	375 0035	816	7,06/7,88	45,00/57,20
	375 0040	775	8,55/9,06	52,50/73,60
	375 0045	859	13,42/9,92	52,50/84,00
	375 0050	953	7,23/19,78	73,80/46,80
	375 0055	1067	12,50/23,46	73,80/57,20
	375 0105	691	4,75/6,90	45,00/62,40
	375 0110	793	8,43/8,53	45,00/72,90

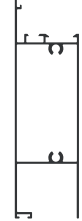
DRAWING	CODE	REL. WEIGHT,(gr/m)	INNERT. MOMENTS $I_x/I_y(\text{cm}^4)$	DIMENSIONS X/Y(mm)
	375 0115	957	21,13/11,17	45,00/95,90
	375 0120	945	20,94/10,02	45,00/93,90
	375 0125	703	5,14/6,66	45,00/62,40
	375 0130	813	9,00/8,37	45,00/72,90
	375 0135	967	22,02/10,95	45,00/93,90
	375 0140	964	21,97/10,03	52,50/93,90
	375 0145	722	4,94/7,04	45,00/57,40
	375 0150	831	8,86/8,87	45,00/67,90
	375 0155	983	22,07/11,49	45,00/88,90

DRAWING	CODE	REL. WEIGHT,(gr/m)	INNERT.MOMENTS $I_x/J_y(\text{cm}^4)$	DIMENSIONS X/Y(mm)
	375 0160	800	6,31/6,67	45,00/57,40
	375 0165	909	10,97/8,48	45,00/67,90
	375 0170	1064	26,14/11,12	45,00/88,90
	375 0205	837	4,88/4,81	37,50/64,80
	375 0210	878	7,71/5,67	37,50/73,00
	375 0215	948	23,55/14,69	37,50/84,00
	375 0220	1298	74,20/10,94	37,50/138,00
	375 0225	1292	67,47/11,36	37,50/130,00
	375 0230	1144	15,91/14,79	58,80/73,00

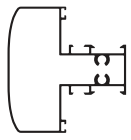
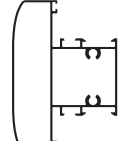
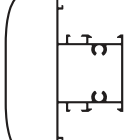
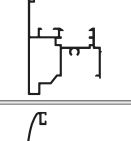
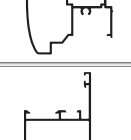
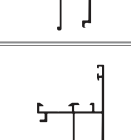
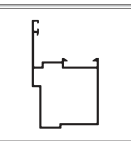
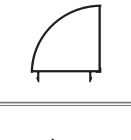
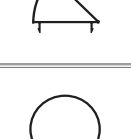
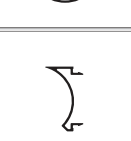
DRAWING	CODE	REL.WEIGHT,(gr/m)	INNERT.MOMENTS $I_x/I_y(\text{cm}^4)$	DIMENSIONS X/Y(mm)
	375 0160	800	6,31/6,67	45,00/57,40
	375 0165	909	10,97/8,48	45,00/67,90
	375 0170	1064	26,14/11,12	45,00/88,90
	375 0205	837	4,88/4,81	37,50/64,80
	375 0210	878	7,71/5,67	37,50/73,00
	375 0215	948	23,55/14,69	37,50/84,00
	375 0220	1298	74,20/10,94	37,50/138,00
	375 0225	1292	67,47/11,36	37,50/130,00
	375 0230	1144	15,91/14,79	58,80/73,00

DRAWING	CODE	REL.WEIGHT,(gr/m)	INNERT.MOMENTS $I_x/J_y(\text{cm}^4)$	DIMENSIONS X/Y(mm)
	375 0235	1192	18,23/19,69	66,30/73,00
	375 0240	1352	29,74/18,09	58,80/88,80
	375 0245	1400	33,20/23,76	66,30/88,80
	375 0305	734	5,49/5,41	41,34/61,00
	375 0310	790	6,60/7,38	48,83/61,00
	375 0315	754	7,80/4,86	37,50/70,20
	375 0320	539	3,33/2,93	37,50/54,60
	375 0325	638	7,50/4,82	37,50/62,90
	375 0330	519	3,98/3,82	39,50/45,00
	375 0335	398	1,22/2,03	38,09/33,43
	375 0340	427	2,96/2,96	40,00/40,00
	375 0345	279	1,92/0,18	21,26/37,50

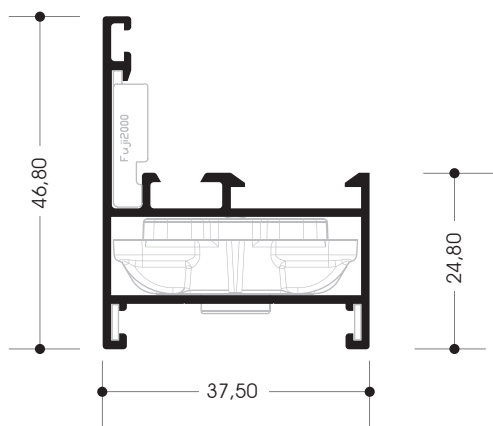

ACCESSORIES	
MECHANICAL PUTTING	0484
ALIGNMENT ANGLE	Fuji2000 5x1
CONGEST GASKETS	OUTER CENTRAL
CAP	1601

FRAME		
CODE	375 0005	
REL.WEIGHT	(gr/m)	580
PERIMETER	(mm)	257
I_x	(cm ⁴)	2,88
J_y	(cm ⁴)	4,22

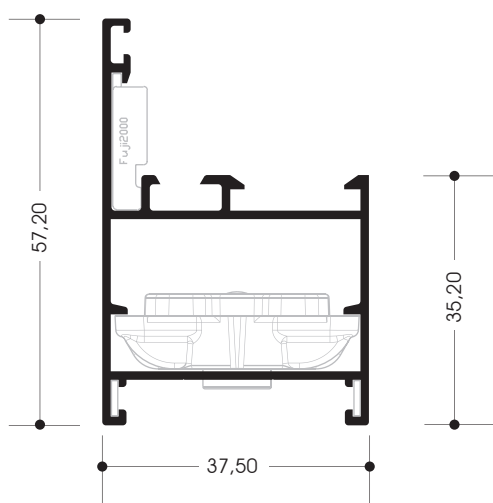

ACCESSORIES	
MECHANICAL PUTTING	0484
ALIGNMENT ANGLE	Fuji2000 5x1
CONGEST GASKETS	OUTER CENTRAL
CAP	1601

FRAME		
CODE	375 0010	
REL.WEIGHT	(gr/m)	663
PERIMETER	(mm)	2,78
I_x	(cm ⁴)	5,55
J_y	(cm ⁴)	5,24

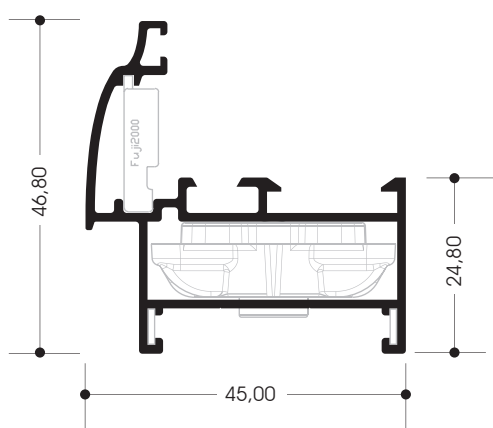

ACCESSORIES	
MECHANICAL PUTTING	0484
ALIGNMENT ANGLE	Fuji2000 5x1
CONGEST GASKETS	OUTER CENTRAL
CAP	1601

FRAME		
CODE	375 0015	
REL.WEIGHT	(gr/m)	640
PERIMETER	(mm)	284
I_x	(cm ⁴)	3,20
J_y	(cm ⁴)	5,43

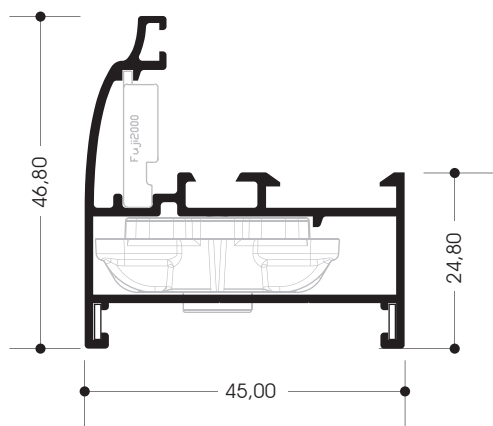

ACCESSORIES	
MECHANICAL PUTTING	0484
ALIGNMENT ANGLE	Fuji2000 5x1
CONGEST GASKETS	OUTER CENTRAL
CAP	1601

FRAME		
CODE	375 0020	
REL.WEIGHT	(gr/m)	664
PERIMETER	(mm)	283
I_x	(cm ⁴)	3,31
J_y	(cm ⁴)	6,20

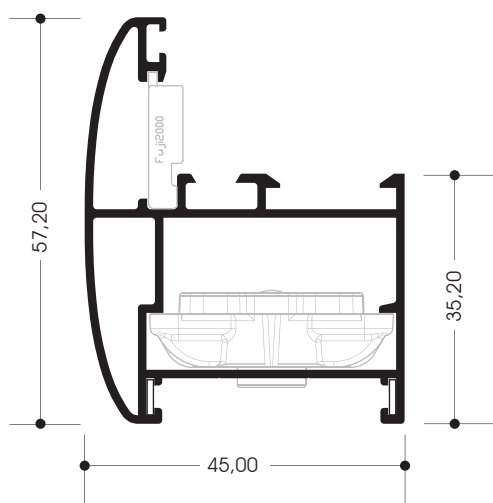

ACCESSORIES	
MECHANICAL PUTTING	0484
ALIGNMENT ANGLE	Fuji2000 5x1
CONGEST GASKETS	OUTER CENTRAL
CAP	1601

FRAME		
CODE	375 0025	
REL.WEIGHT	(gr/m)	821
PERIMETER	(mm)	311
I_x	(cm ⁴)	7,24
J_y	(cm ⁴)	7,57

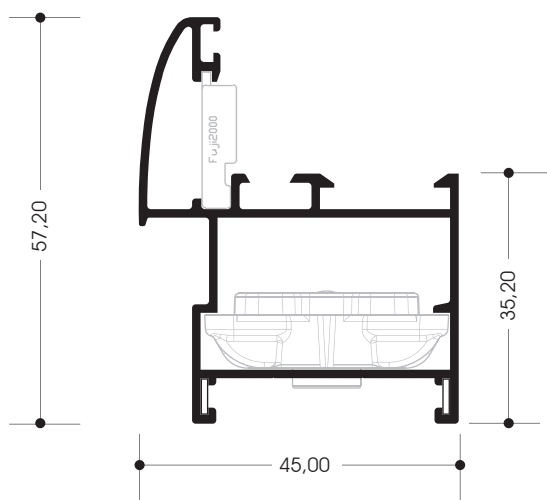

ACCESSORIES	
MECHANICAL PUTTING	0484
ALIGNMENT ANGLE	Fuji2000 5x1
CONGEST GASKETS	OUTER CENTRAL
CAP	1601

FRAME		
CODE	375 0030	
REL.WEIGHT	(gr/m)	725
PERIMETER	(mm)	322
I_x	(cm ⁴)	6,59
J_y	(cm ⁴)	6,45

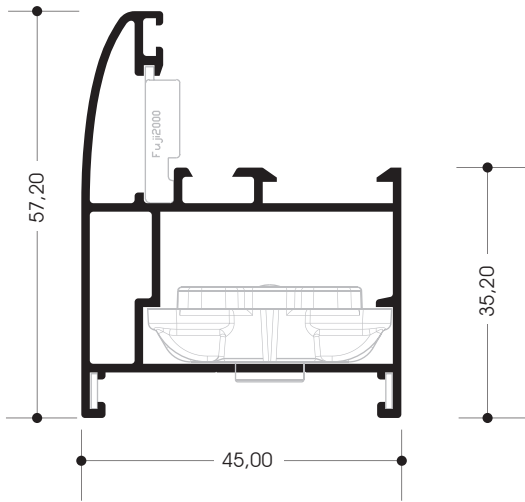

FRAME		
CODE	375 0035	
REL.WEIGHT	(gr/m)	816
PERIMETER	(mm)	316
I_x	(cm ⁴)	7,06
J_y	(cm ⁴)	7,88

ACCESSORIES	
MECHANICAL PUTTING	0484
ALIGNMENT ANGLE	Fuji2000 5x1
CONGEST GASKETS	OUTER CENTRAL
CAP	1601

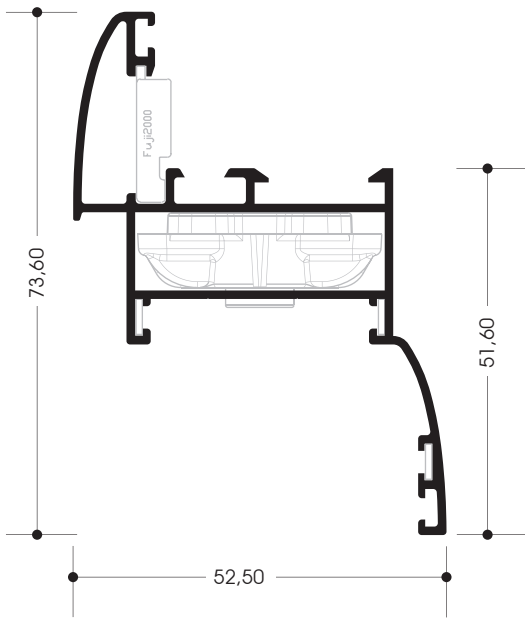

FRAME		
CODE	375 0040	
REL.WEIGHT	(gr/m)	775
PERIMETER	(mm)	376
I_x	(cm ⁴)	8,55
J_y	(cm ⁴)	9,06

ACCESSORIES	
MECHANICAL PUTTING	0484
ALIGNMENT ANGLE	Fuji2000 5x1
CONGEST GASKETS	OUTER CENTRAL
CAP	1601

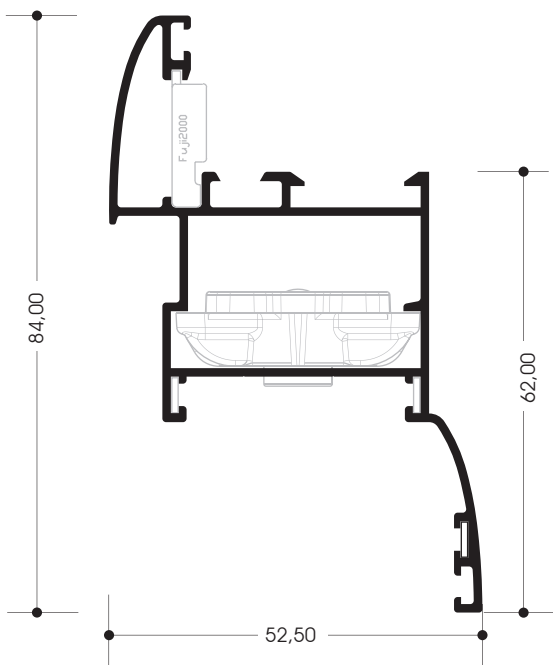

FRAME		
CODE	375 0045	
REL.WEIGHT	(gr/m)	859
PERIMETER	(mm)	401
I_x	(cm ⁴)	13,42
J_y	(cm ⁴)	9,92

ACCESSORIES	
MECHANICAL PUTTING	0484
ALIGNMENT ANGLE	Fuji2000 5x1
CONGEST GASKETS	OUTER CENTRAL
CAP	1601

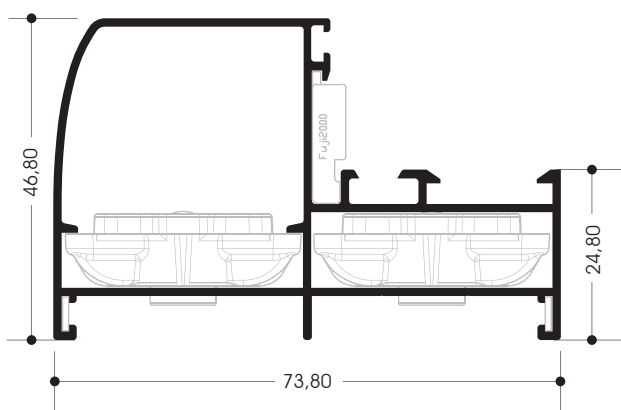

ACCESSORIES	
MECHANICAL PUTTING	0484
ALIGNMENT ANGLE	Fuji2000 5x1
CONGEST GASKETS	OUTER CENTRAL
CAP	1601

FRAME		
CODE	375 0050	
REL.WEIGHT	(gr/m)	953
PERIMETER	(mm)	337
I_x	(cm ⁴)	7,23
J_y	(cm ⁴)	19,78

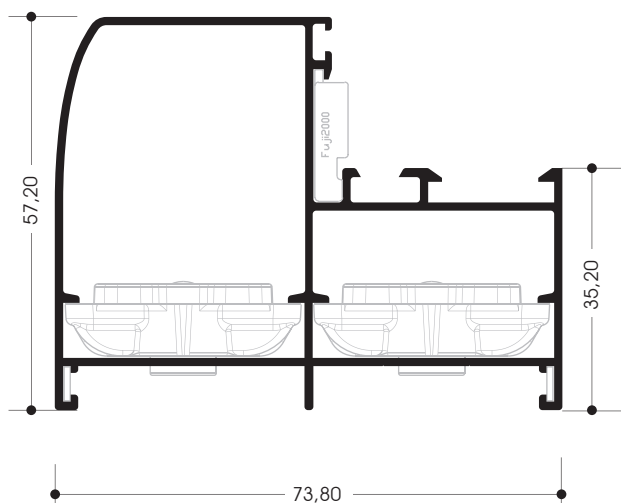

ACCESSORIES	
MECHANICAL PUTTING	0484
ALIGNMENT ANGLE	Fuji2000 5x1
CONGEST GASKETS	OUTER CENTRAL
CAP	1601

FRAME		
CODE	375 0055	
REL.WEIGHT	(gr/m)	1067
PERIMETER	(mm)	358
I_x	(cm ⁴)	12,50
J_y	(cm ⁴)	23,46

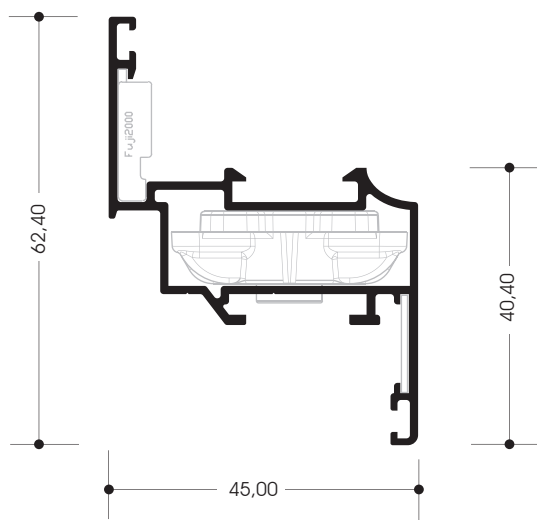

ACCESSORIES	
MECHANICAL PUTTING	0484
ALIGNMENT ANGLE	Fuji2000 14,1x1,2
CONGEST GASKETS	INNER GLASS-OUT
CAP	1601

SASH		
CODE	375 0105	
REL.WEIGHT	(gr/m)	691
PERIMETER	(mm)	302
I_x	(cm ⁴)	4,75
J_y	(cm ⁴)	6,90

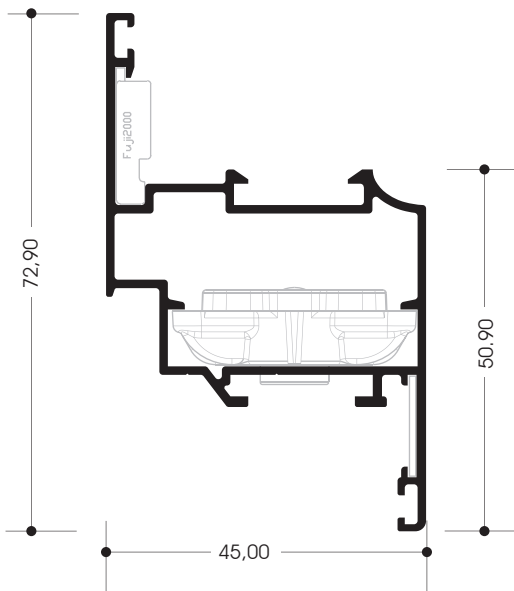

SASH		
CODE	375 0110	
REL.WEIGHT	(gr/m)	793
PERIMETER	(mm)	323
I_x	(cm ⁴)	8,43
J_y	(cm ⁴)	8,53

ACCESSORIES	
MECHANICAL PUTTING	0484
ALIGNMENT ANGLE	Fuji2000 14,1x1,2
CONGEST GASKETS	INNER GLASS-OUT
CAP	1601

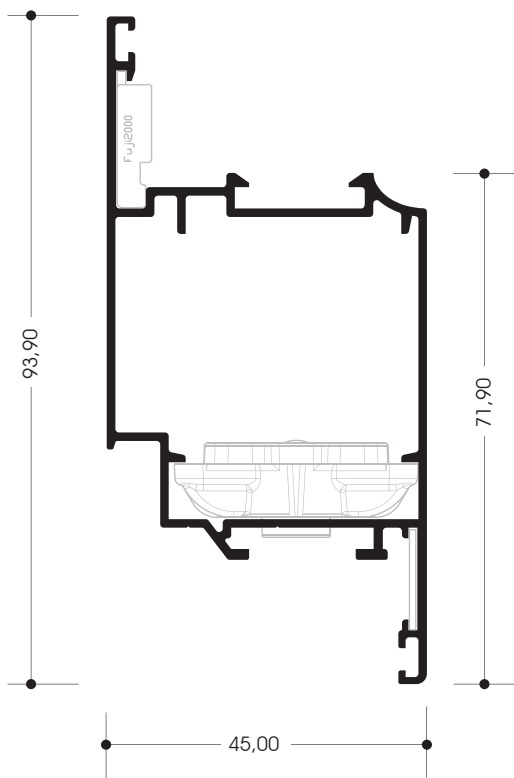

SASH		
CODE	375 0115	
REL.WEIGHT	(gr/m)	957
PERIMETER	(mm)	365
I_x	(cm ⁴)	21,13
J_y	(cm ⁴)	11,17

ACCESSORIES	
MECHANICAL PUTTING	0484
ALIGNMENT ANGLE	Fuji2000 14,1x1,2
CONGEST GASKETS	INNER GLASS-OUT
CAP	1601

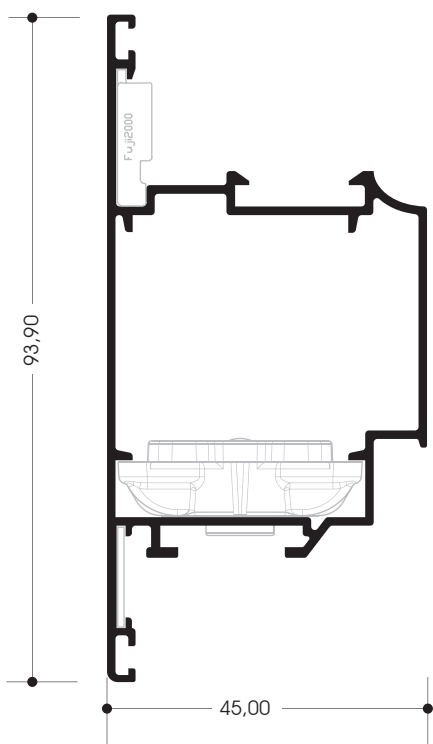

ACCESSORIES	
MECHANICAL PUTTING	0484
ALIGNMENT ANGLE	Fuji2000 14,1x1,2
CONGEST GASKETS	INNER GLASS-OUT
CAP	1601

SASH		
CODE	375 0120	
REL.WEIGHT	(gr/m)	945
PERIMETER	(mm)	365
I _x	(cm ⁴)	20,94
J _y	(cm ⁴)	10,02

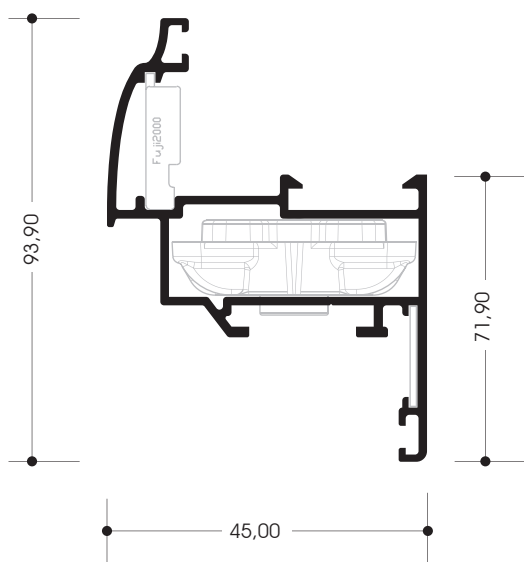

ACCESSORIES	
MECHANICAL PUTTING	0484
ALIGNMENT ANGLE	Fuji2000 14,1x1,2
CONGEST GASKETS	INNER GLASS-OUT
CAP	1601

SASH		
CODE	375 0125	
REL.WEIGHT	(gr/m)	703
PERIMETER	(mm)	316
I _x	(cm ⁴)	5,14
J _y	(cm ⁴)	6,66

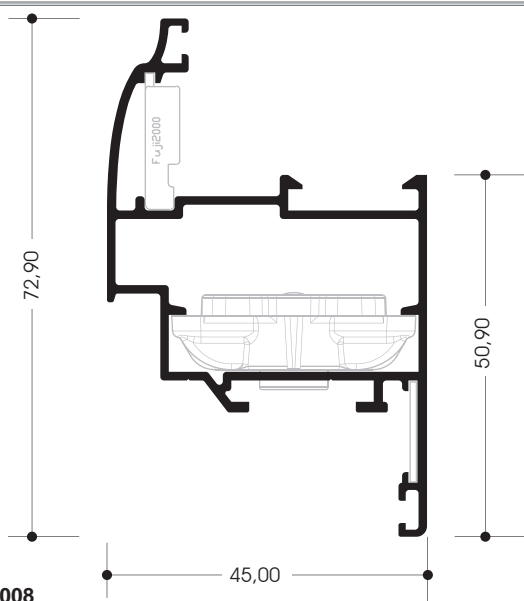

ACCESSORIES	
MECHANICAL PUTTING	0484
ALIGNMENT ANGLE	Fuji2000 14,1x1,2
CONGEST GASKETS	INNER GLASS-OUT
CAP	1601

SASH		
CODE	375 0130	
REL.WEIGHT	(gr/m)	813
PERIMETER	(mm)	337
I _x	(cm ⁴)	9,00
J _y	(cm ⁴)	8,37

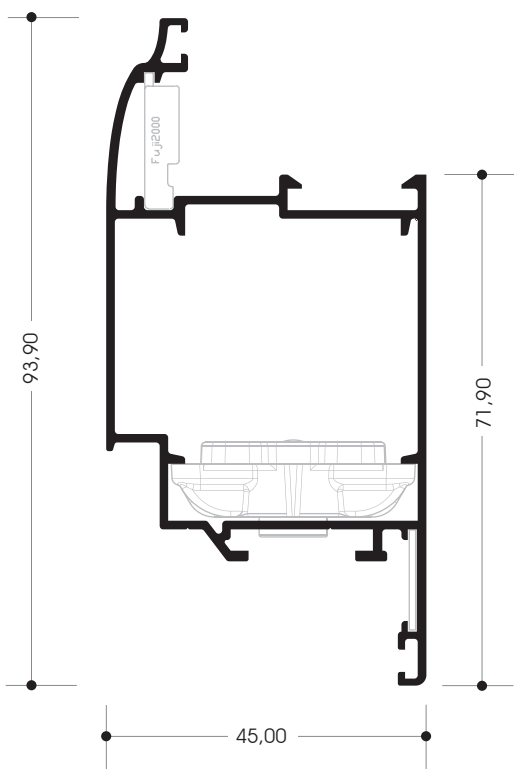

SASH		
CODE	375 0135	
REL.WEIGHT	(gr/m)	967
PERIMETER	(mm)	379
I_x	(cm ⁴)	22,02
J_y	(cm ⁴)	10,95

ACCESSORIES	
MECHANICAL PUTTING	0484
ALIGNMENT ANGLE	Fuji2000 14,1x1,2
CONGEST GASKETS	INNER GLASS-OUT
CAP	1601

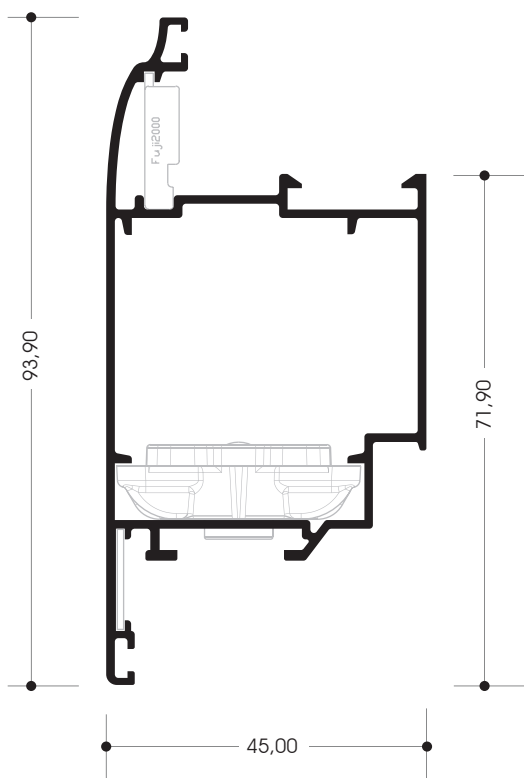

SASH		
CODE	375 0140	
REL.WEIGHT	(gr/m)	964
PERIMETER	(mm)	379
I_x	(cm ⁴)	21,97
J_y	(cm ⁴)	10,03

ACCESSORIES	
MECHANICAL PUTTING	0484
ALIGNMENT ANGLE	Fuji2000 14,1x1,2
CONGEST GASKETS	INNER GLASS-OUT
CAP	1601

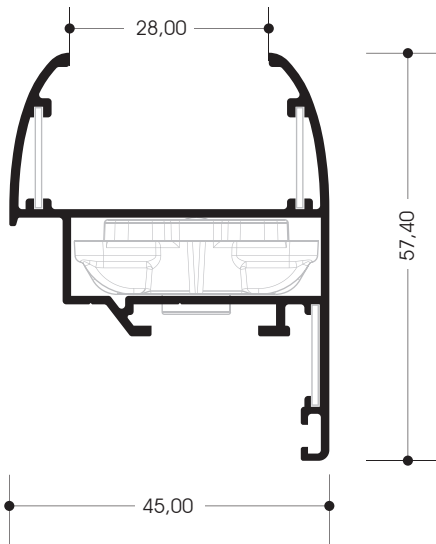

ACCESSORIES	
MECHANICAL PUTTING	0484
ALIGNMENT ANGLE	Fuji2000 14,1x1,2
CONGEST GASKETS	INNER GLASS-OUT GLASS-INN
CAP	1601

SASH		
CODE	375 0145	
REL.WEIGHT	(gr/m)	722
PERIMETER	(mm)	330
I_x	(cm ⁴)	4,94
J_y	(cm ⁴)	7,04

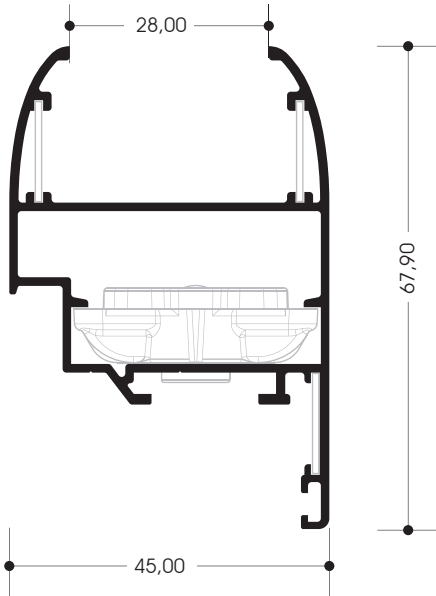

ACCESSORIES	
MECHANICAL PUTTING	0484
ALIGNMENT ANGLE	Fuji2000 14,1x1,2
CONGEST GASKETS	INNER GLASS-OUT GLASS-INN
CAP	1601

SASH		
CODE	375 0150	
REL.WEIGHT	(gr/m)	831
PERIMETER	(mm)	351
I_x	(cm ⁴)	8,86
J_y	(cm ⁴)	8,87

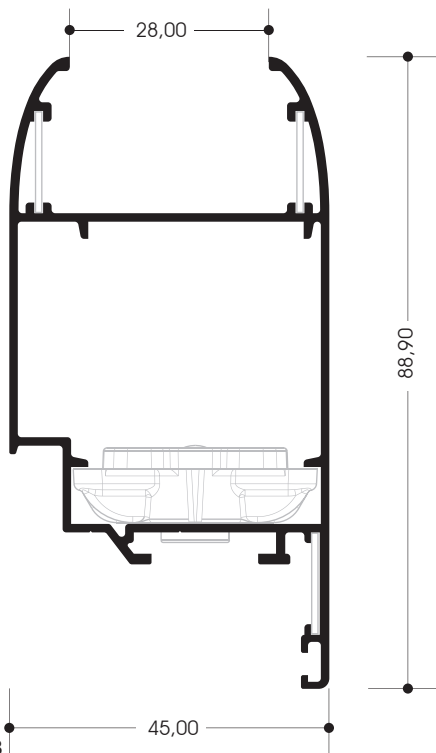

ACCESSORIES	
MECHANICAL PUTTING	0484
ALIGNMENT ANGLE	Fuji2000 14,1x1,2
CONGEST GASKETS	INNER GLASS-OUT GLASS-INN
CAP	1601

SASH		
CODE	375 0155	
REL.WEIGHT	(gr/m)	983
PERIMETER	(mm)	393
I_x	(cm ⁴)	22,07
J_y	(cm ⁴)	11,49

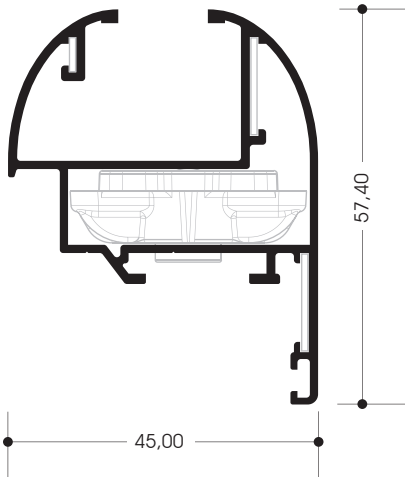

ACCESSORIES	
MECHANICAL PUTTING	0484
ALIGNMENT ANGLE	Fuji2000 14,1x1,2
CONGEST GASKETS	INNER GLASS-OUT GLASS-INN
CAP	1601

SASH		
CODE	375 0160	
REL.WEIGHT	(gr/m)	800
PERIMETER	(mm)	333
I_x	(cm ⁴)	6,31
J_y	(cm ⁴)	6,67

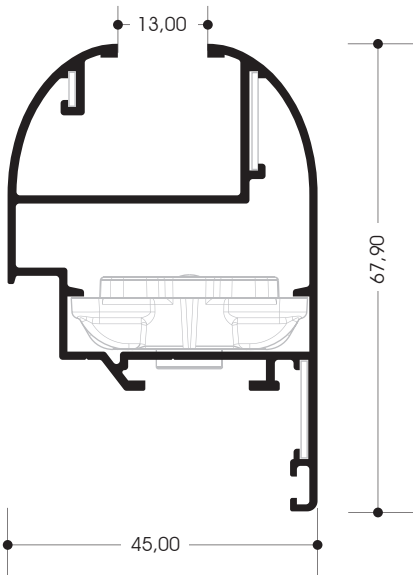

ACCESSORIES	
MECHANICAL PUTTING	0484
ALIGNMENT ANGLE	Fuji2000 14,1x1,2
CONGEST GASKETS	INNER GLASS-OUT GLASS-INN
CAP	1601

SASH		
CODE	375 0165	
REL.WEIGHT	(gr/m)	909
PERIMETER	(mm)	354
I_x	(cm ⁴)	10,97
J_y	(cm ⁴)	8,48

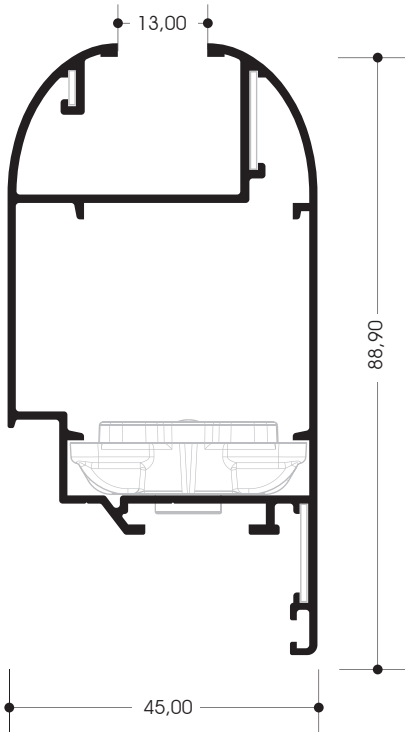

ACCESSORIES	
MECHANICAL PUTTING	0484
ALIGNMENT ANGLE	Fuji2000 14,1x1,2
CONGEST GASKETS	INNER GLASS-OUT GLASS-INN
CAP	1601

SASH		
CODE	375 0170	
REL.WEIGHT	(gr/m)	1064
PERIMETER	(mm)	396
I_x	(cm ⁴)	26,14
J_y	(cm ⁴)	11,12

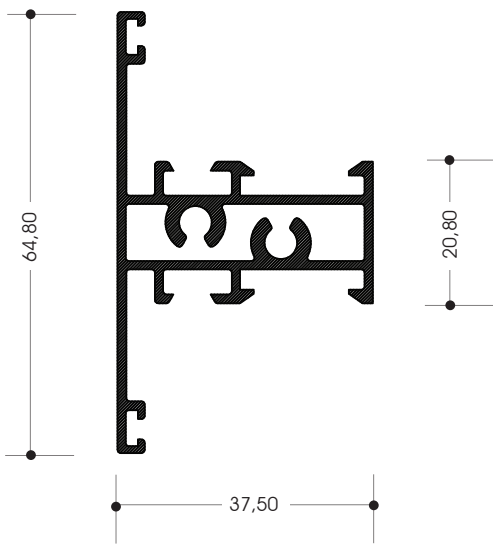

MULLION		
CODE	375 0205	
REL.WEIGHT	(gr/m)	837
PERIMETER	(mm)	318
I_x	(cm ⁴)	4,88
J_y	(cm ⁴)	4,81

ACCESSORIES	
SCREWS	4 PCS
CONGEST GASKETS	CENTRAL OUTER
	GLASS-OUT
CAP	1601

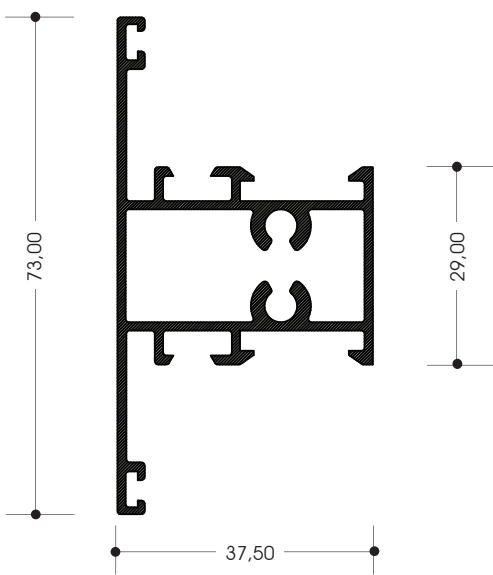

MULLION		
CODE	375 0210	
REL.WEIGHT	(gr/m)	878
PERIMETER	(mm)	334
I_x	(cm ⁴)	7,71
J_y	(cm ⁴)	5,67

ACCESSORIES	
SCREWS	4 PCS
CONGEST GASKETS	CENTRAL OUTER
	GLASS-OUT
CAP	1601

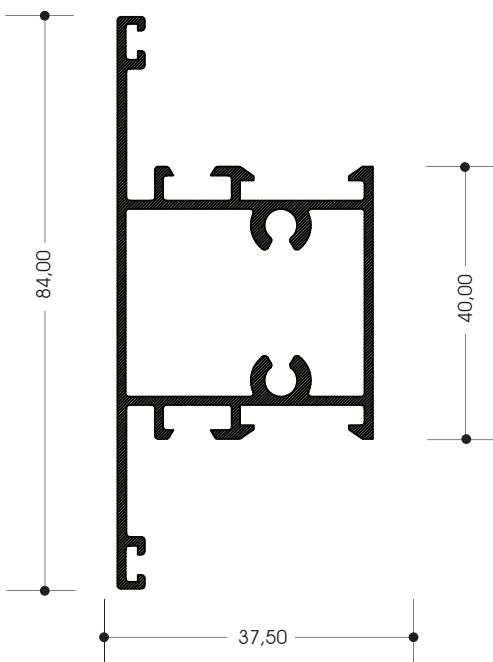

MULLION		
CODE	375 0215	
REL.WEIGHT	(gr/m)	948
PERIMETER	(mm)	356
I_x	(cm ⁴)	23,55
J_y	(cm ⁴)	14,69

ACCESSORIES	
SCREWS	4 PCS
CONGEST GASKETS	CENTRAL OUTER
	GLASS-OUT
CAP	1601

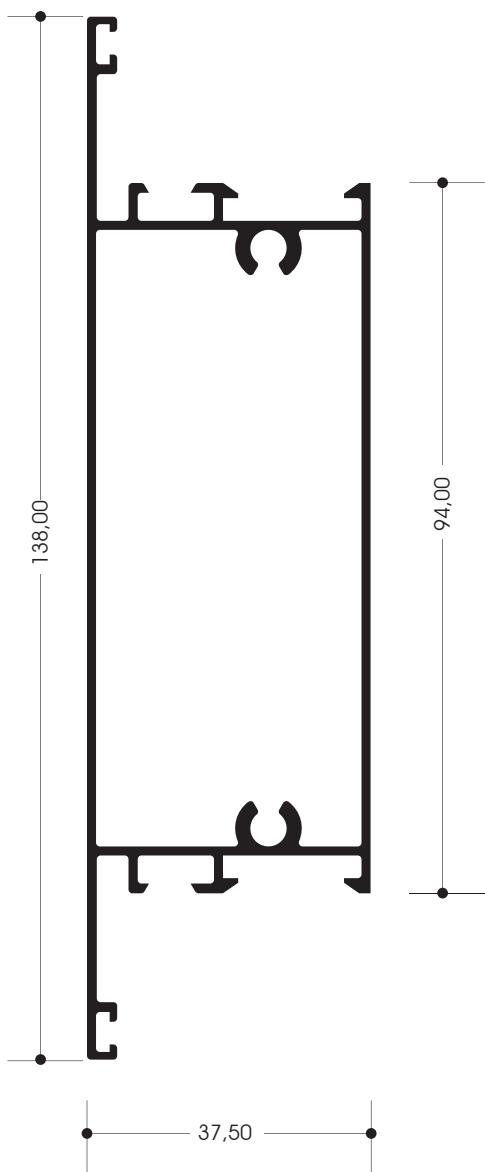

MULLION		
CODE	375 0220	
REL.WEIGHT	(gr/m)	1298
PERIMETER	(mm)	464
I_x	(cm ⁴)	74,20
J_y	(cm ⁴)	10,94

ACCESSORIES	
SCREWS	4 PCS
CONGEST GASKETS	CENTRAL OUTER
	GLASS-OUT
CAP	1601

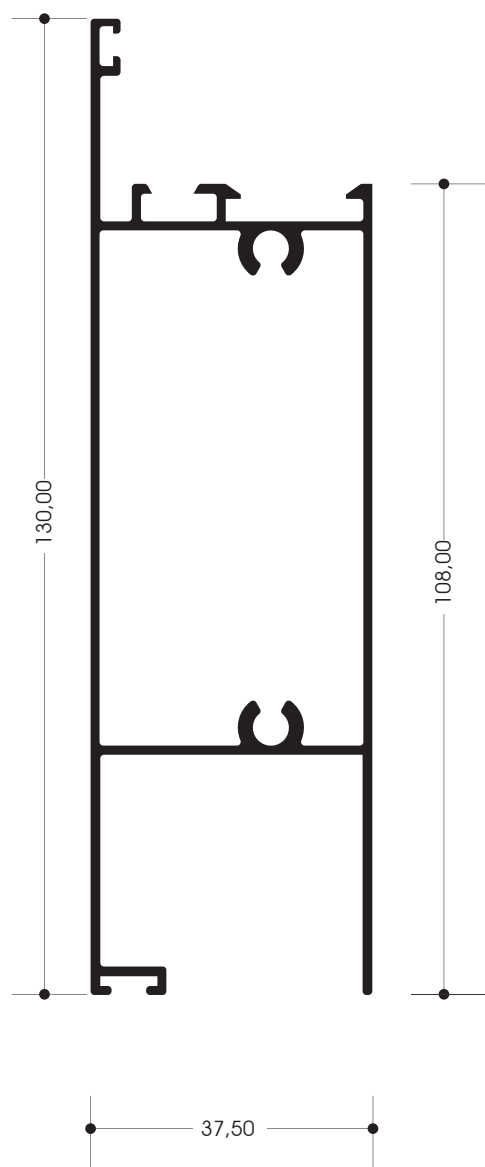

BOARD FOR DOOR		
CODE	375 0225	
REL.WEIGHT	(gr/m)	1292
PERIMETER	(mm)	482
I_x	(cm ⁴)	67,47
J_y	(cm ⁴)	11,36

ACCESSORIES	
SCREWS	4 PCS
CONGEST GASKETS	GLASS-OUT
CAP	1601
BRUSH	8 (mm)
CONGEST SYSTEM	1PCS

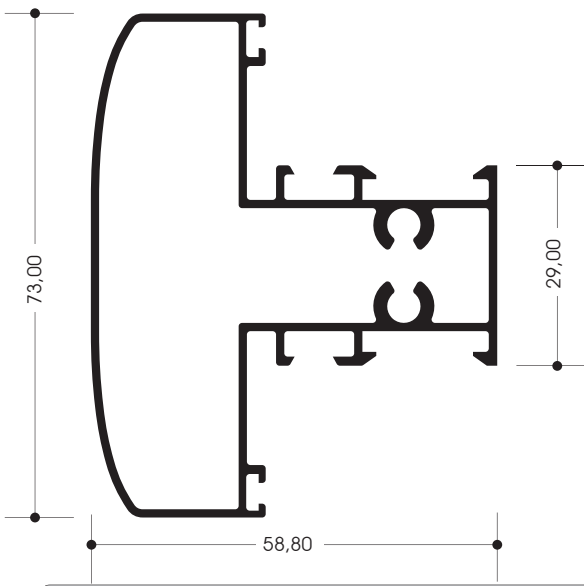

ACCESSORIES	
SCREWS	4 PCS
CONGEST GASKETS	CENTRAL OUTER
	GLASS-OUT
CAP	1601

MULLION		
CODE	375 0230	
REL.WEIGHT	(gr/m)	1144
PERIMETER	(mm)	367
I_x	(cm ⁴)	15,91
J_y	(cm ⁴)	14,79

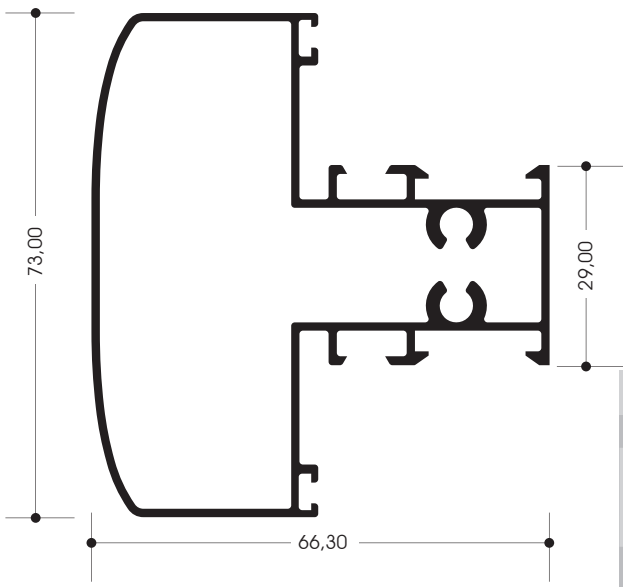

ACCESSORIES	
SCREWS	4 PCS
CONGEST GASKETS	CENTRAL OUTER
	GLASS-OUT
CAP	1601

MULLION		
CODE	375 0235	
REL.WEIGHT	(gr/m)	1192
PERIMETER	(mm)	382
I_x	(cm ⁴)	18,23
J_y	(cm ⁴)	19,69

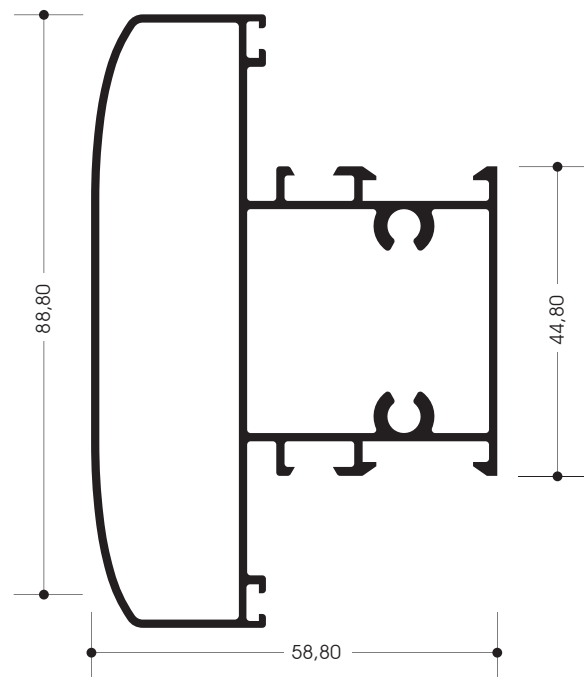

ACCESSORIES	
SCREWS	4 PCS
CONGEST GASKETS	CENTRAL OUTER
	GLASS-OUT
CAP	1601

MULLION		
CODE	375 0240	
REL.WEIGHT	(gr/m)	1352
PERIMETER	(mm)	399
I_x	(cm ⁴)	29,74
J_y	(cm ⁴)	18,09

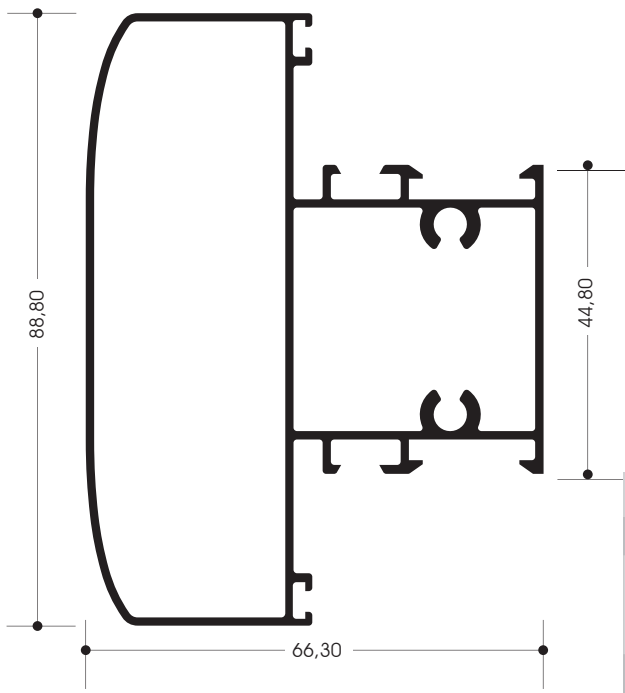

MULLION		
CODE	375 0245	
REL.WEIGHT	(gr/m)	1400
PERIMETER	(mm)	414
I_x	(cm ⁴)	33,20
J_y	(cm ⁴)	23,76

ACCESSORIES	
SCREWS	4 PCS
CONGEST GASKETS	CENTRAL
	OUTER
CAP	GLASS-OUT
	1601

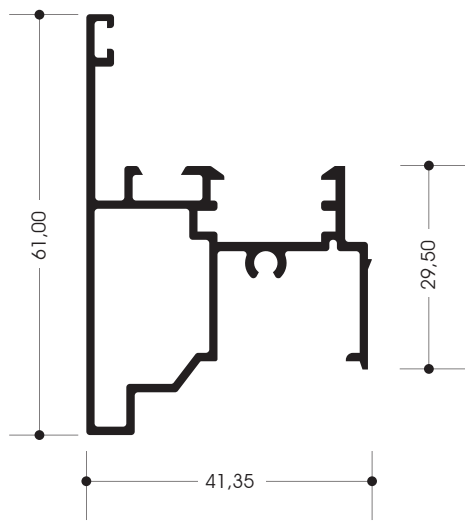

OVERHUNG		
CODE	375 0305	
REL.WEIGHT	(gr/m)	734
PERIMETER	(mm)	332
I_x	(cm ⁴)	5,49
J_y	(cm ⁴)	5,41

ACCESSORIES	
SCREWS	2 PCS
CONGEST GASKETS	CENTRAL
	OUTER
CAP	AP375

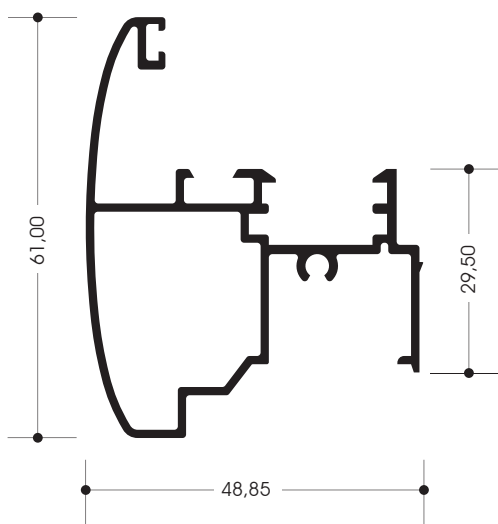

OVERHUNG		
CODE	375 0310	
REL.WEIGHT	(gr/m)	790
PERIMETER	(mm)	359
I_x	(cm ⁴)	6,60
J_y	(cm ⁴)	7,38

ACCESSORIES	
SCREWS	2 PCS
CONGEST GASKETS	CENTRAL
	OUTER
CAP	AP375

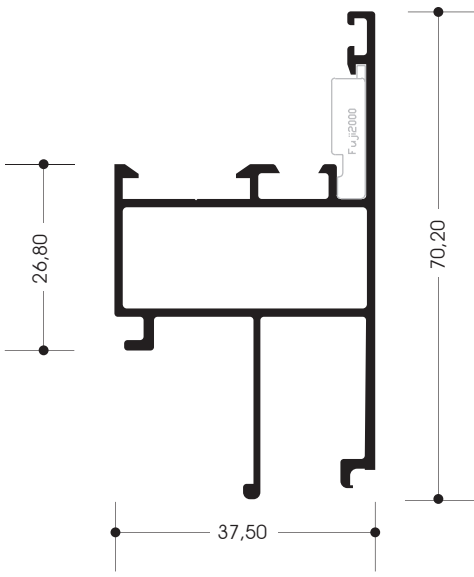

ACCESSORIES	
CONGEST GASKETS	CENTRAL OUTER
ALIGNMENT ANGLE	Fuji2000

PROF. OUTER OPENING		
CODE	375 0315	
REL.WEIGHT	(gr/m)	754
PERIMETER	(mm)	347
I_x	(cm ⁴)	7,80
J_y	(cm ⁴)	4,86

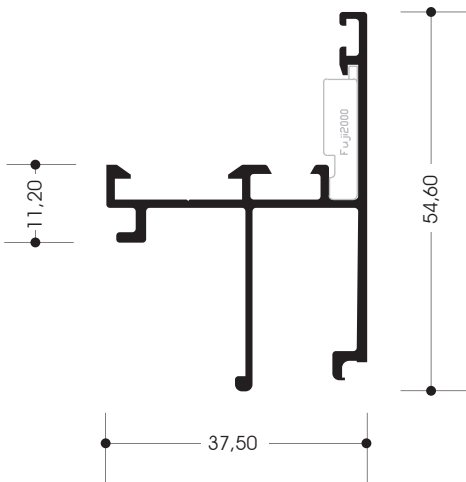

ACCESSORIES	
CONGEST GASKETS	CENTRAL OUTER
ALIGNMENT ANGLE	Fuji2000

PROF. OUTER OPENING		
CODE	375 0320	
REL.WEIGHT	(gr/m)	539
PERIMETER	(mm)	317
I_x	(cm ⁴)	3,33
J_y	(cm ⁴)	2,93

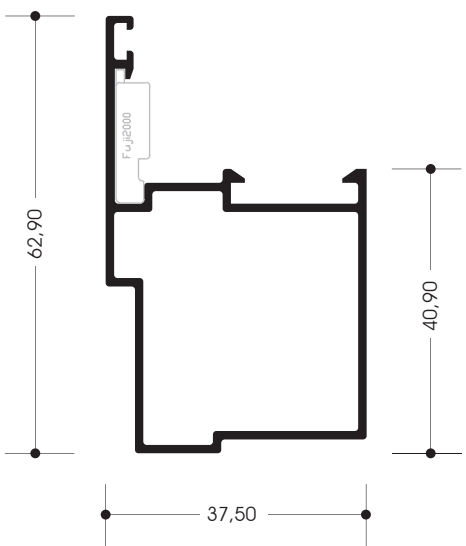

ACCESSORIES	
CONGEST GASKETS	OUTER
ALIGNMENT ANGLE	Fuji2000

ADDITION FOR DOOR		
CODE	375 0325	
REL.WEIGHT	(gr/m)	638
PERIMETER	(mm)	242
I_x	(cm ⁴)	7,50
J_y	(cm ⁴)	4,82

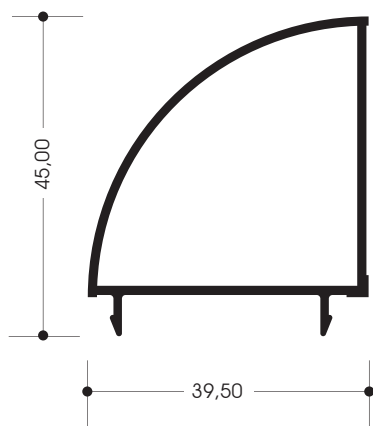

COLUMN FOR ANGLE 90°

CODE	375 0330	
REL.WEIGHT	(gr/m)	519
PERIMETER	(mm)	164
I_x	(cm ⁴)	3,98
J_y	(cm ⁴)	3,82

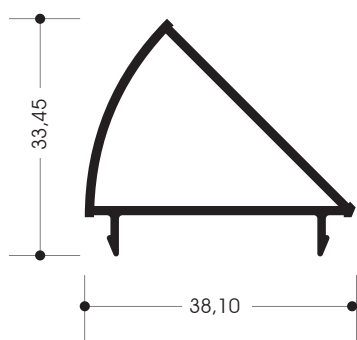

COLUMN FOR ANGLE 135°

CODE	375 0335	
REL.WEIGHT	(gr/m)	398
PERIMETER	(mm)	131
I_x	(cm ⁴)	1,22
J_y	(cm ⁴)	2,03

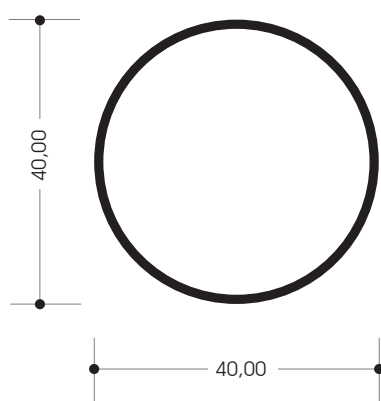

PIPE

CODE	375 0340	
REL.WEIGHT	(gr/m)	427
PERIMETER	(mm)	126
I_x	(cm ⁴)	2,96
J_y	(cm ⁴)	2,96

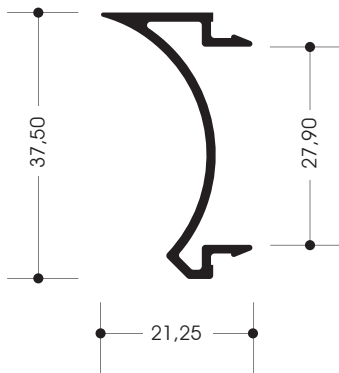

ADDITION FOR PIPE

CODE	375 0345	
REL.WEIGHT	(gr/m)	279
PERIMETER	(mm)	156
I_x	(cm ⁴)	1,92
J_y	(cm ⁴)	0,18

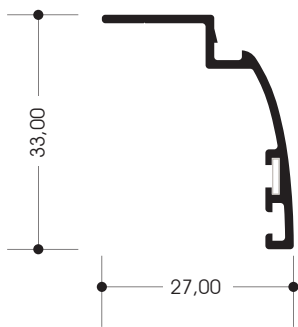

DECORATION PROFILE

CODE	375 0350	
REL.WEIGHT	(gr/m)	222
PERIMETER	(mm)	133
I_x	(cm ⁴)	0,99
J_y	(cm ⁴)	0,44

ACCESSORIES

CONGEST GASKETS	INNER
ALIGNMENT ANGLE	5x1

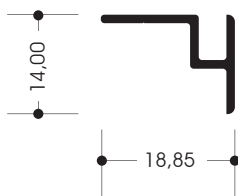

DECORATION PROFILE

CODE	375 0355	
REL.WEIGHT	(gr/m)	122
PERIMETER	(mm)	76
I_x	(cm ⁴)	0,07
J_y	(cm ⁴)	0,14

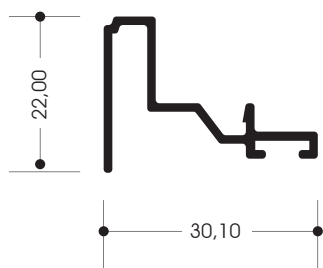

ADDITION FOR DOOR		
CODE	375 0360	
REL.WEIGHT	(gr/m)	254
PERIMETER	(mm)	153
I_x	(cm ⁴)	0,35
J_y	(cm ⁴)	0,89

ACCESSORIES	
SCREWS	N PCS
BRUSH	8 (mm)

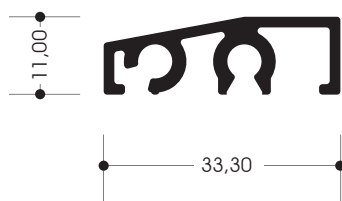

DOOR-SILL		
CODE	375 0365	
REL.WEIGHT	(gr/m)	391
PERIMETER	(mm)	161
I_x	(cm ⁴)	0,15
J_y	(cm ⁴)	1,41

ACCESSORIES	
SCREWS	4 PCS

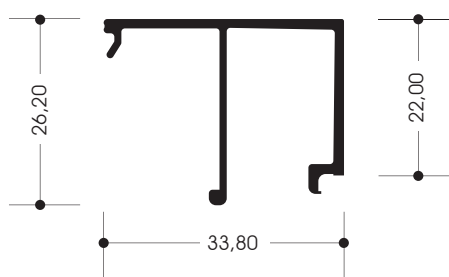

GLASSHOLDER		
CODE	375 0510	
REL.WEIGHT	(gr/m)	314
PERIMETER	(mm)	183
I_x	(cm ⁴)	0,87
J_y	(cm ⁴)	1,26

ACCESSORIES	
CONGEST GASKETS	GLASS INNER

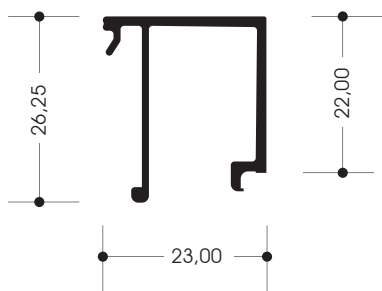

GLASSHOLDER

CODE	375 0520	
REL.WEIGHT	(gr/m)	276
PERIMETER	(mm)	161
I_x	(cm ⁴)	0,77
J_y	(cm ⁴)	0,64

ACCESSORIES

CONGEST GASKETS GLASS INNER

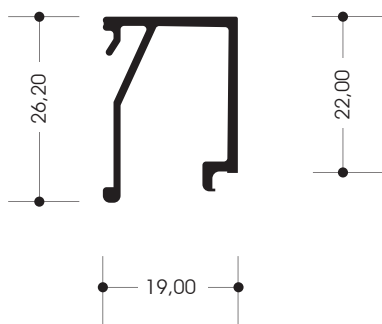

GLASSHOLDER

CODE	375 0530	
REL.WEIGHT	(gr/m)	269
PERIMETER	(mm)	155
I_x	(cm ⁴)	0,73
J_y	(cm ⁴)	0,50

ACCESSORIES

CONGEST GASKETS GLASS INNER

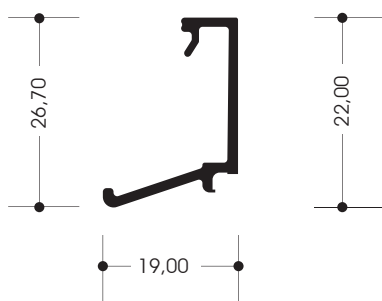

GLASSHOLDER

CODE	375 0540	
REL.WEIGHT	(gr/m)	206
PERIMETER	(mm)	110
I_x	(cm ⁴)	0,66
J_y	(cm ⁴)	0,22

ACCESSORIES

CONGEST GASKETS GLASS INNER

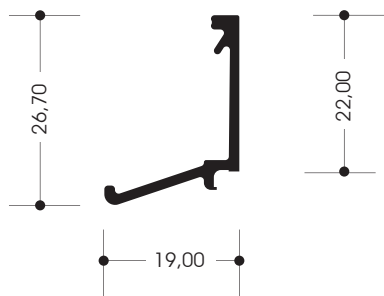

GLASSHOLDER

CODE	375 0550	
REL.WEIGHT	(gr/m)	193
PERIMETER	(mm)	96
I_x	(cm ⁴)	0,56
J_y	(cm ⁴)	0,22

ACCESSORIES

CONGEST GASKETS GLASS INNER

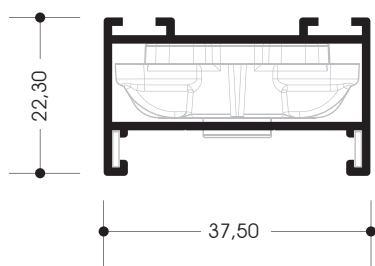

FRAME FOR TWO-SIDE

CODE	375 0405	
REL.WEIGHT	(gr/m)	433
PERIMETER	(mm)	174
I_x	(cm ⁴)	0,76
J_y	(cm ⁴)	3,07

ACCESSORIES

MECHANICAL PUTTING 0484
ALIGNMENT ANGLE 5x1
BRUSH 8 (mm)

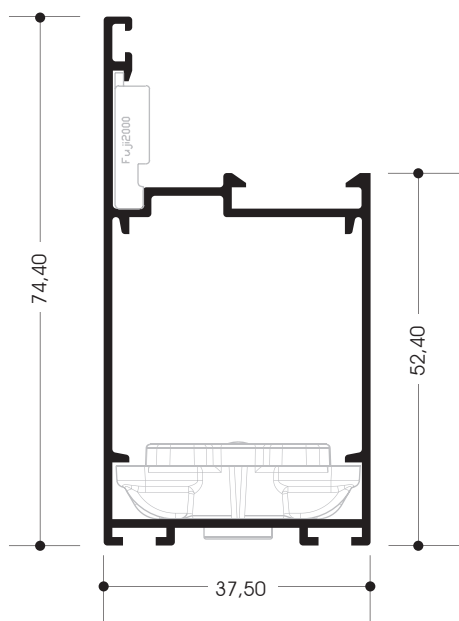

SASH FOR TWO-SIDE

CODE	375 0410	
REL.WEIGHT	(gr/m)	781
PERIMETER	(mm)	292
I_x	(cm ⁴)	14,23
J_y	(cm ⁴)	6,70

ACCESSORIES

MECHANICAL PUTTING 0484
ALIGNMENT ANGLE Fuji2000
BRUSH 8 (mm)
CONGEST GASKETS GLASS OUTER

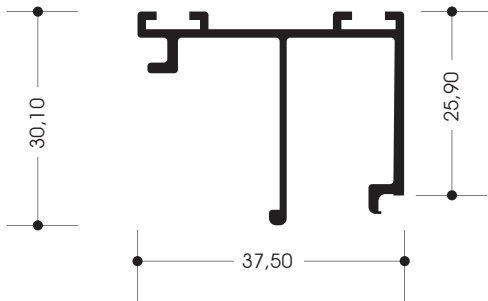

ADDITION FOR TWO-SIDE

CODE	375 0415	
REL.WEIGHT	(gr/m)	392
PERIMETER	(mm)	233
I_x	(cm ⁴)	1,20
J_y	(cm ⁴)	2,17

ACCESSORIES

BRUSH	8 (mm)
-------	--------

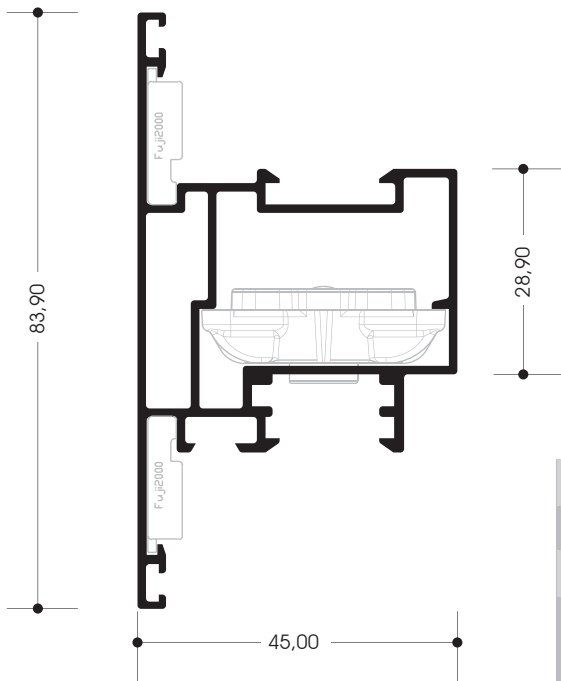

SASH FOR CENTRAL AXIS

CODE	375 0420	
REL.WEIGHT	(gr/m)	1051
PERIMETER	(mm)	379
I_x	(cm ⁴)	13,57
J_y	(cm ⁴)	9,47

ACCESSORIES

MECHANICAL PUTTING	0484
ALIGNMENT ANGLE	Fuji2000
CONGEST GASKETS	CENTRAL OUTER GLASS OUT

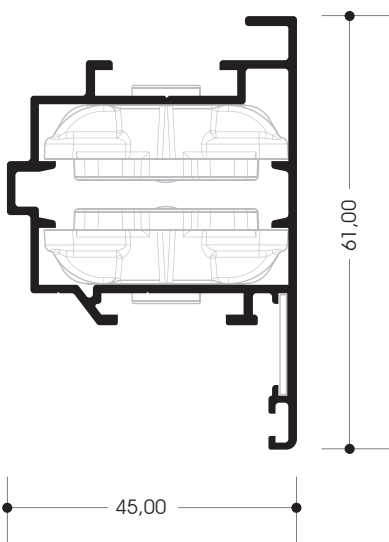

ADDITION FOR CENTRAL AXIS

CODE	375 0425	
REL.WEIGHT	(gr/m)	734
PERIMETER	(mm)	279
I_x	(cm ⁴)	6,83
J_y	(cm ⁴)	5,78

ACCESSORIES

MECHANICAL PUTTING	0484
ALIGNMENT ANGLE	14,1x1,2
CONGEST GASKETS	INNER

GLASSPACKETS

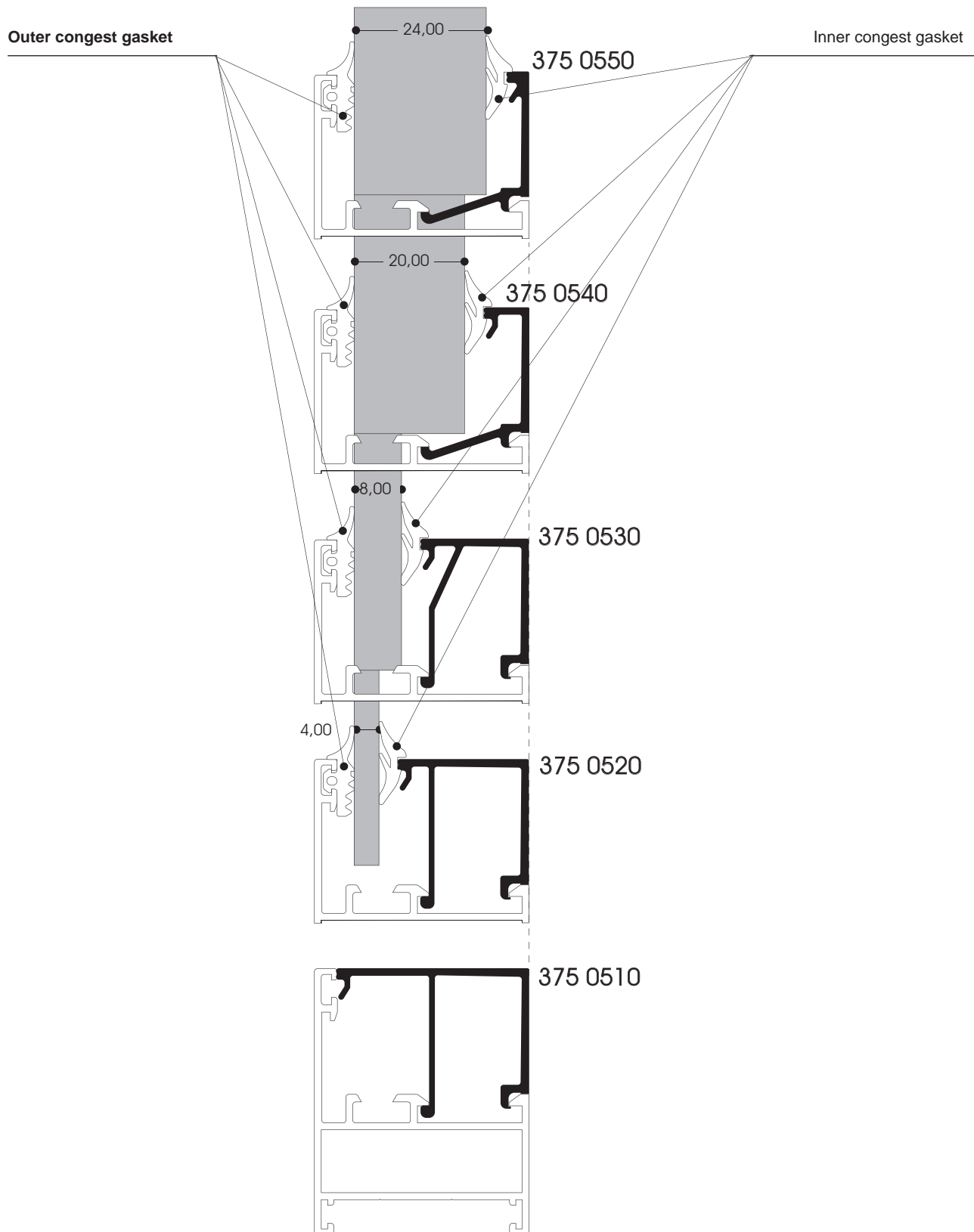

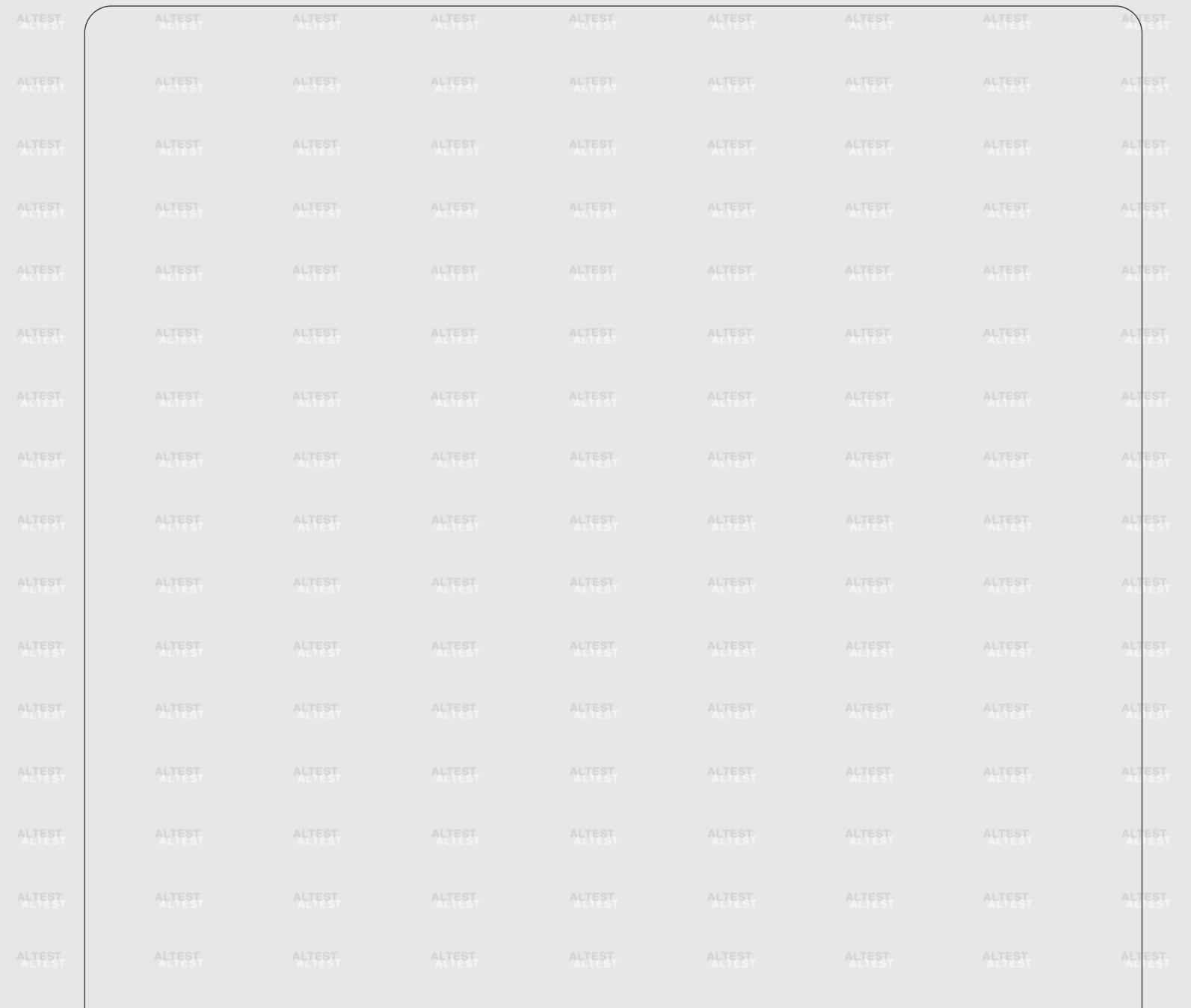

Sections



ASPECT SECTIONS

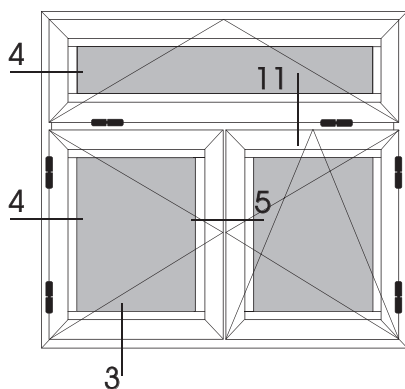
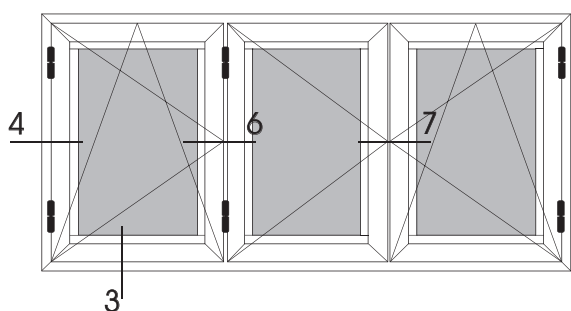
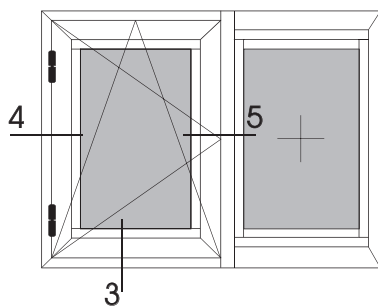
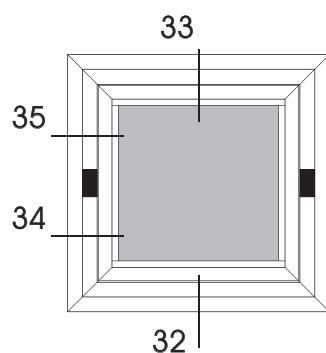
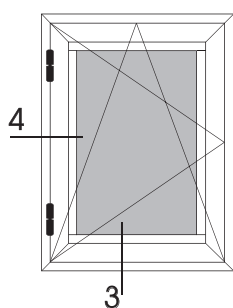
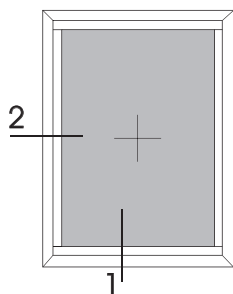

ASPECT SECTIONS

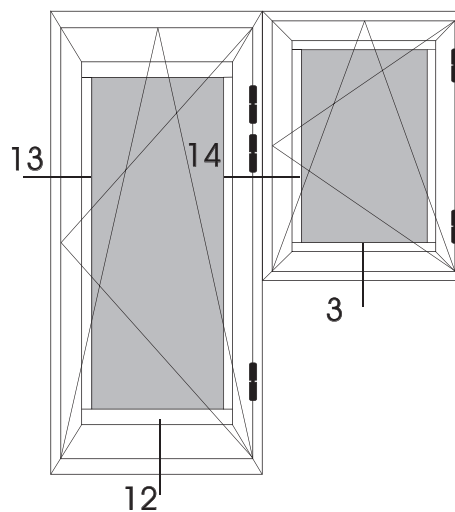
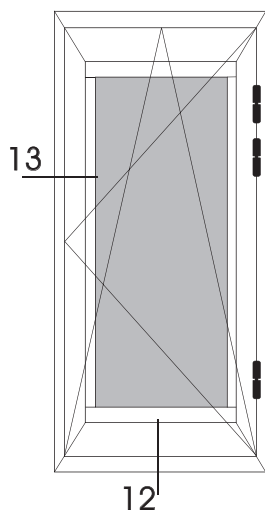
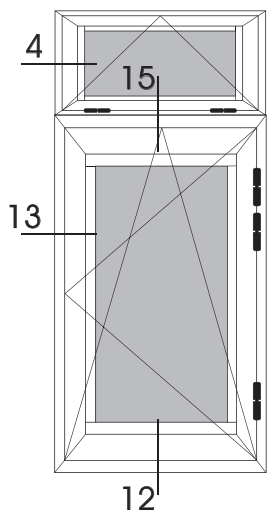
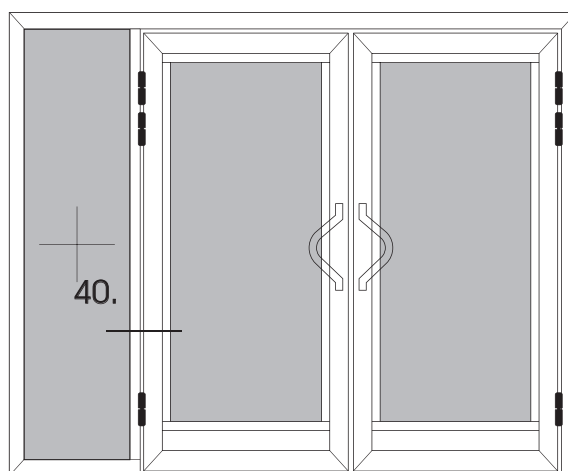
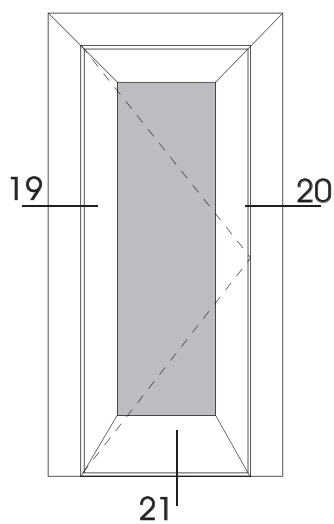
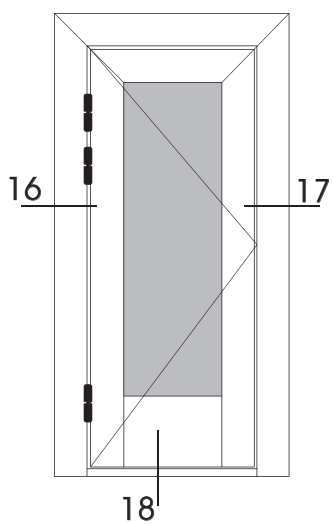
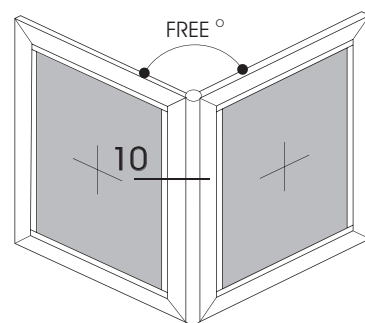
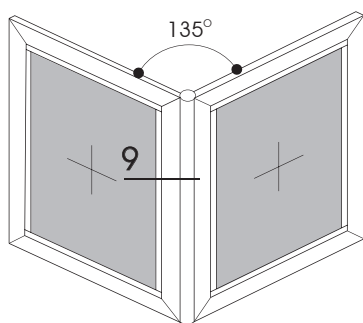
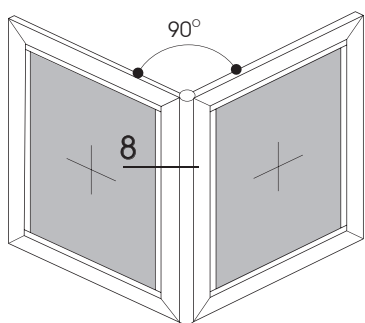

ASPECT SECTIONS

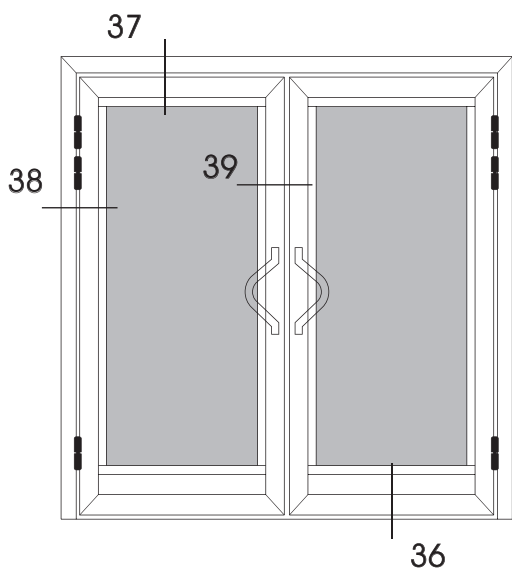
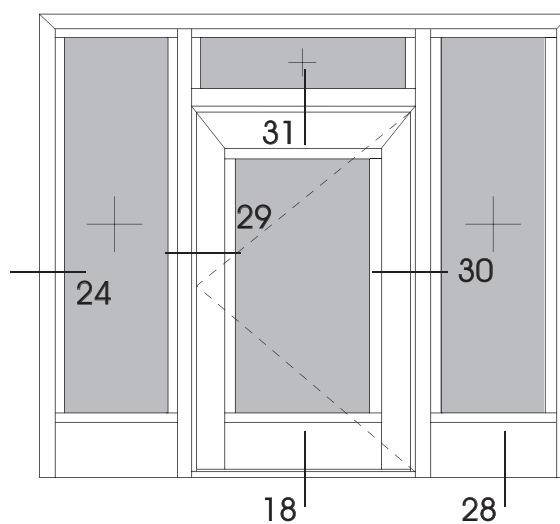
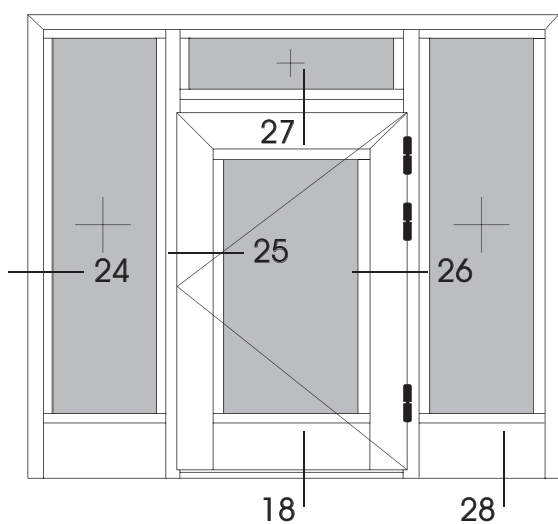
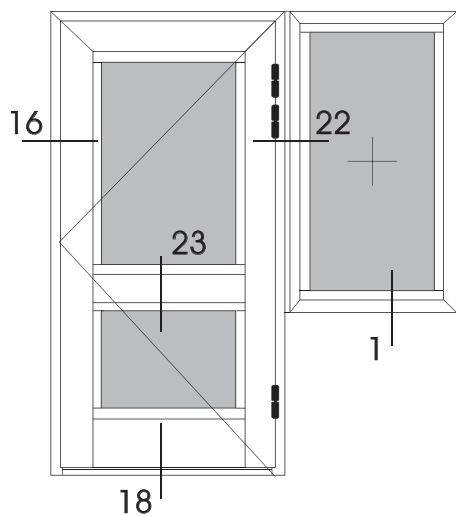

SECTIONS

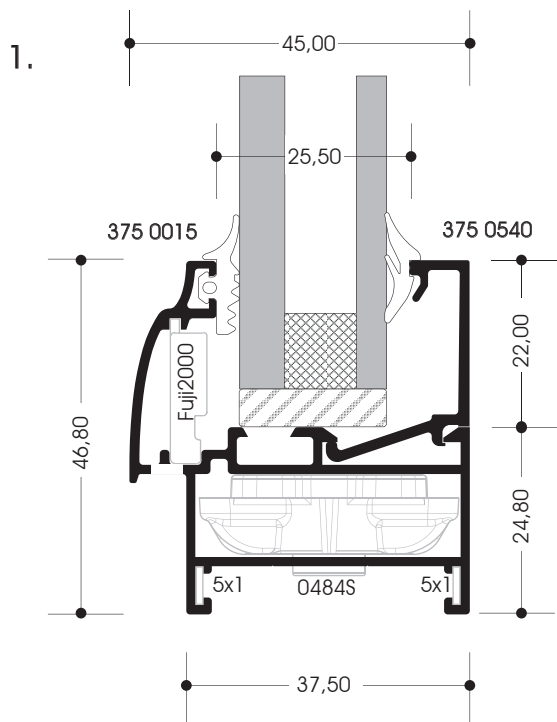
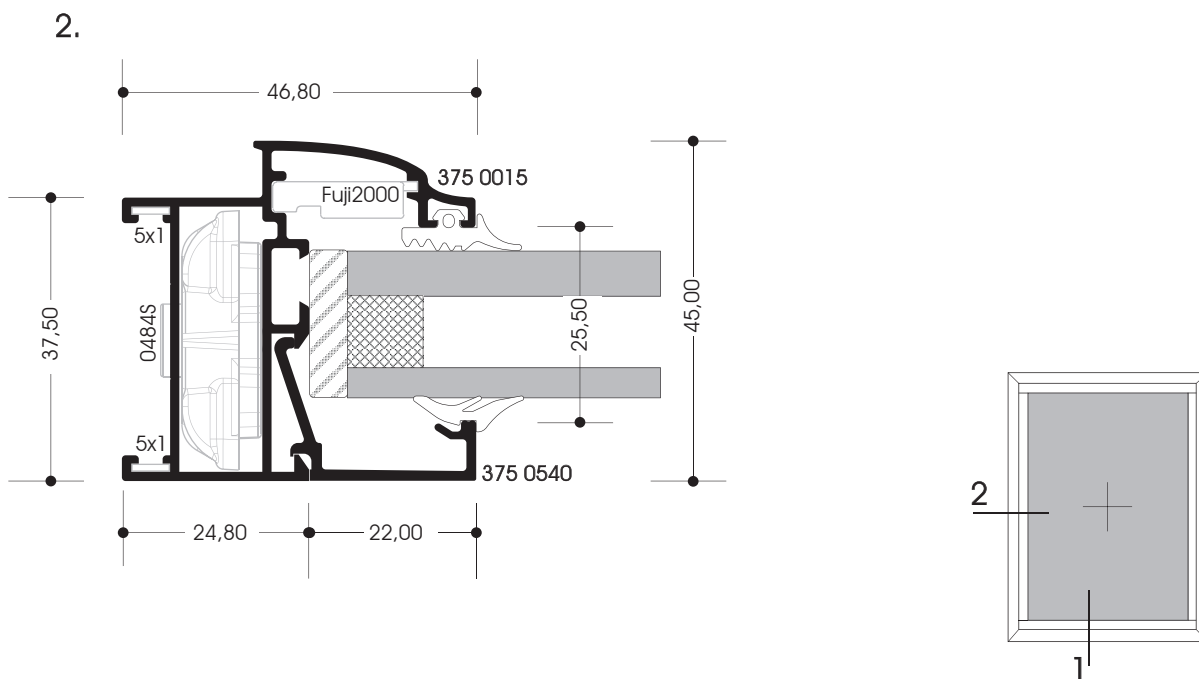

SECTIONS

2a.

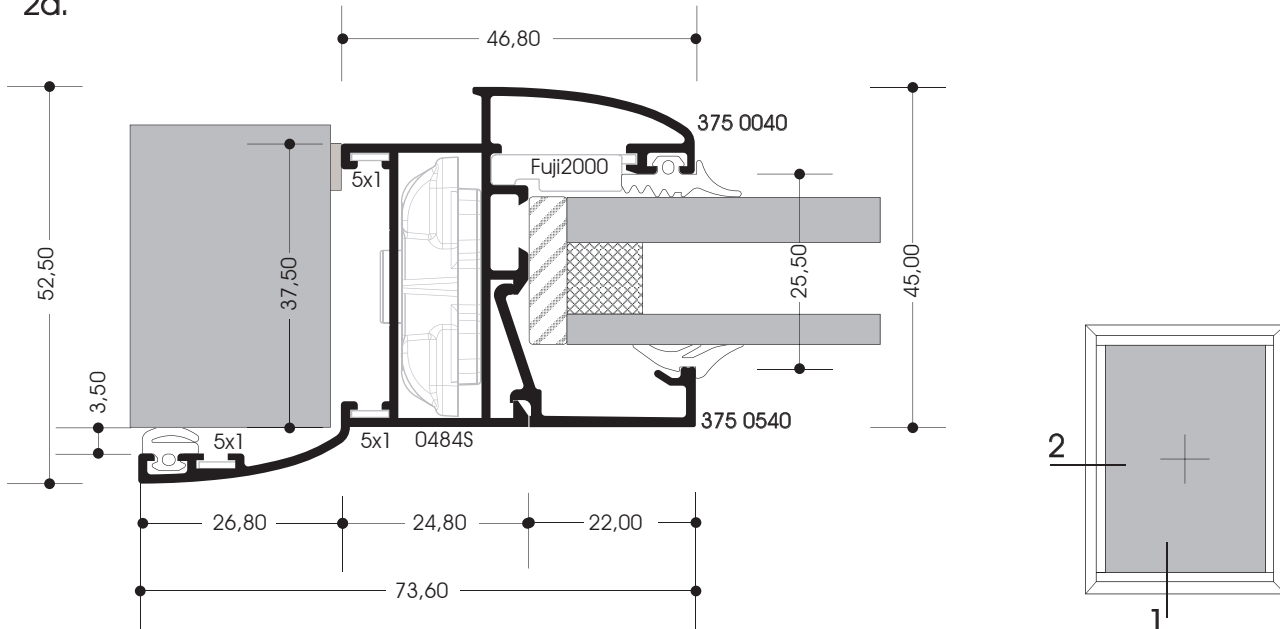

1a.

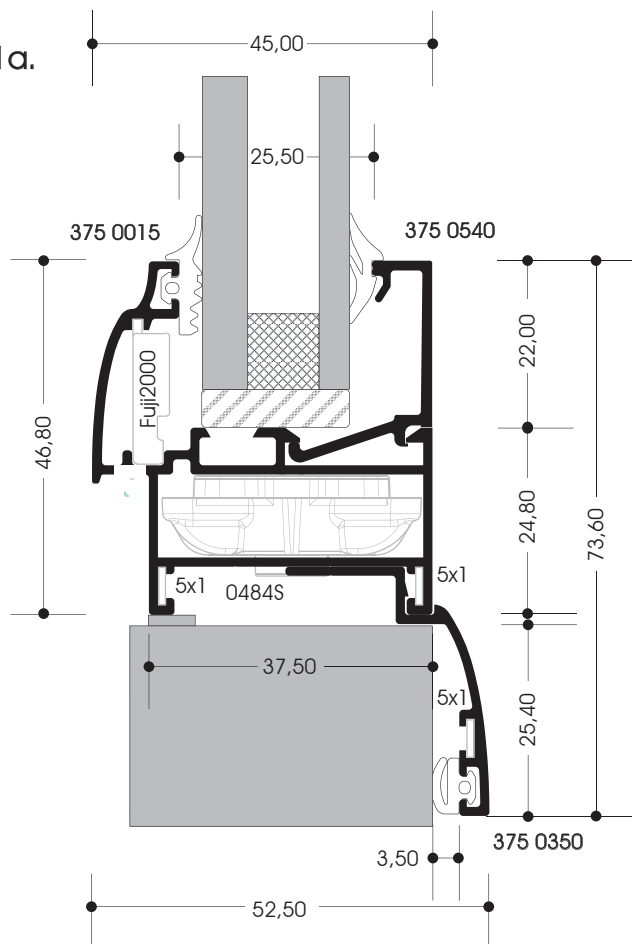

SECTIONS

4.

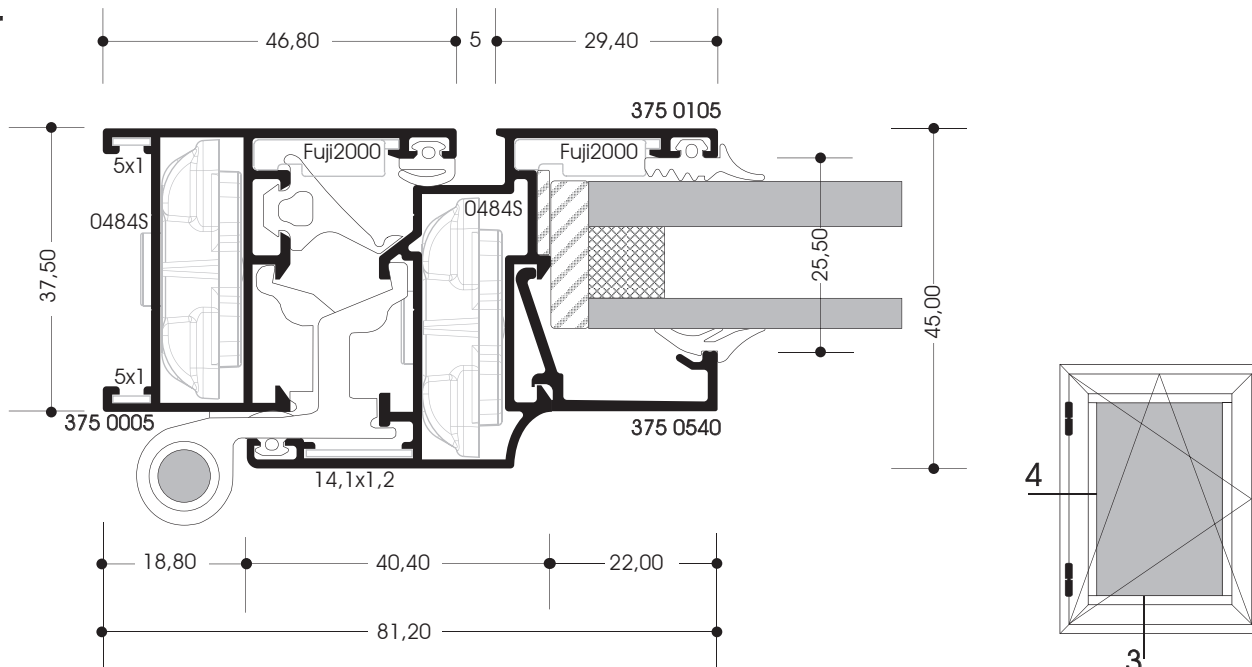

3.

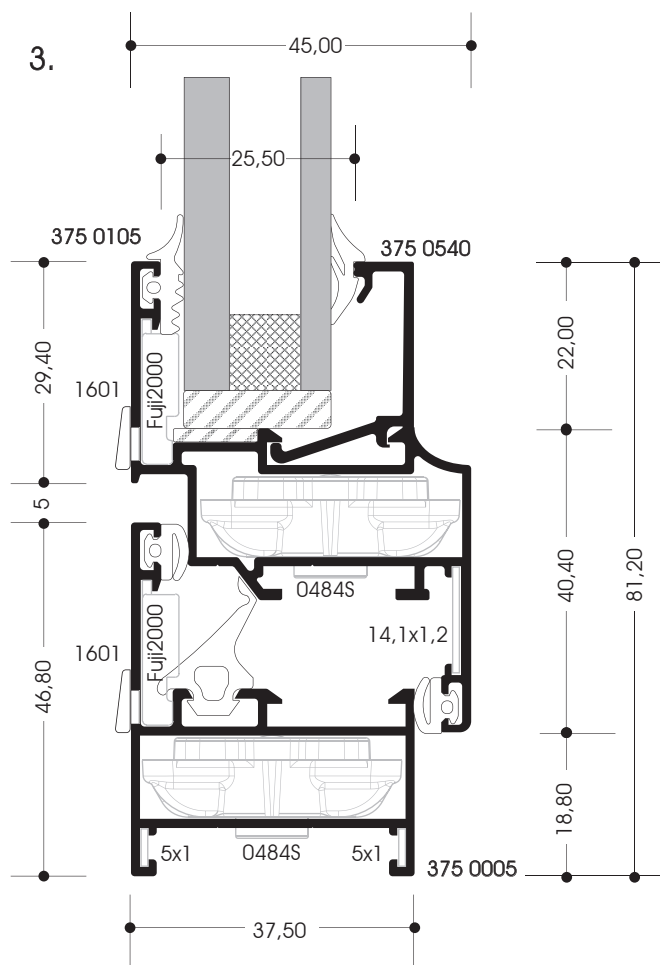

SECTIONS

4a.

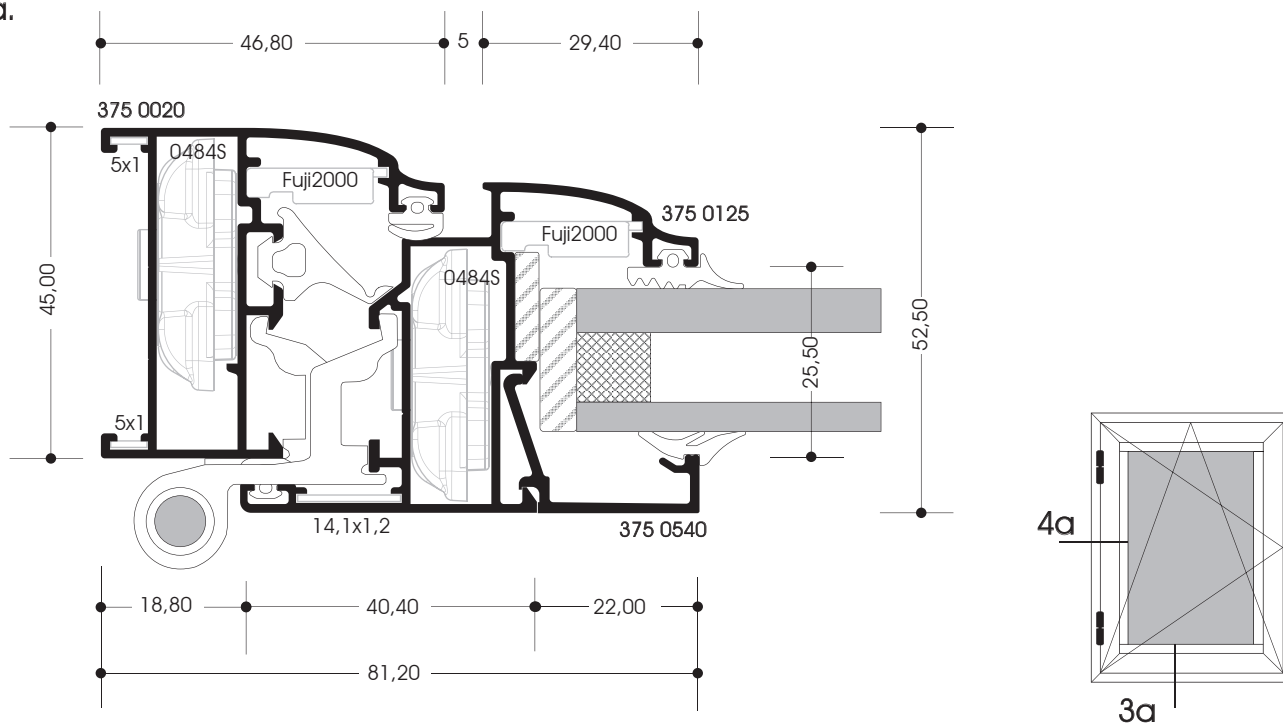

3.

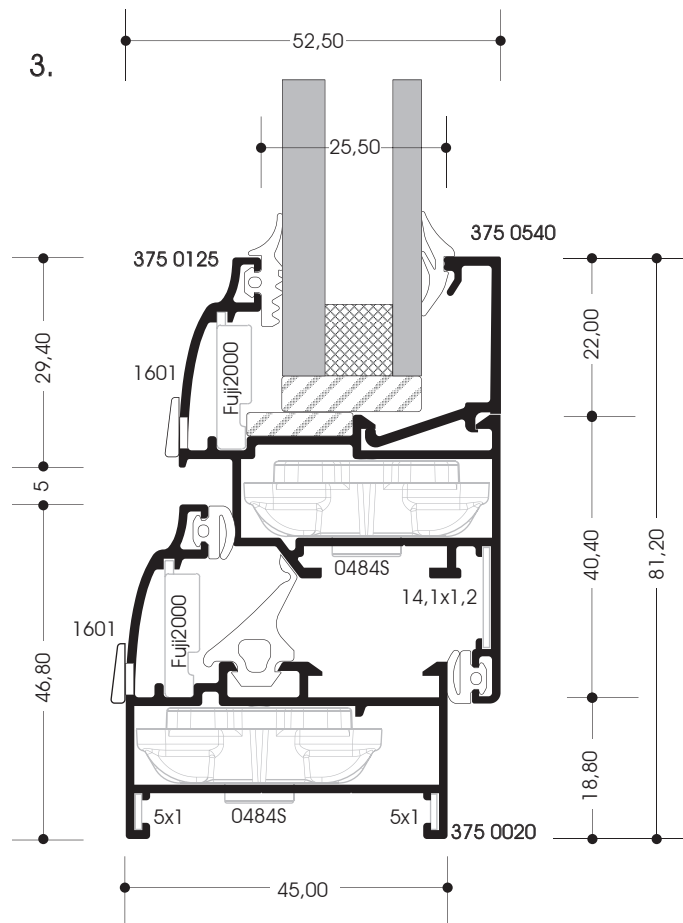

SECTIONS

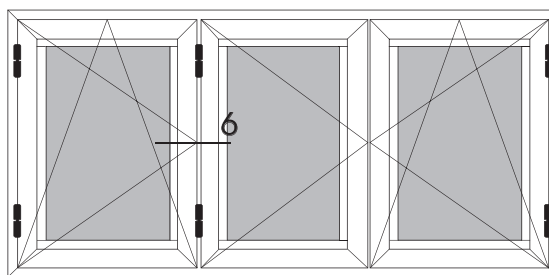
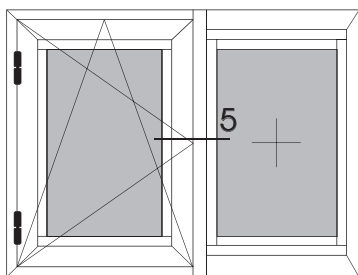
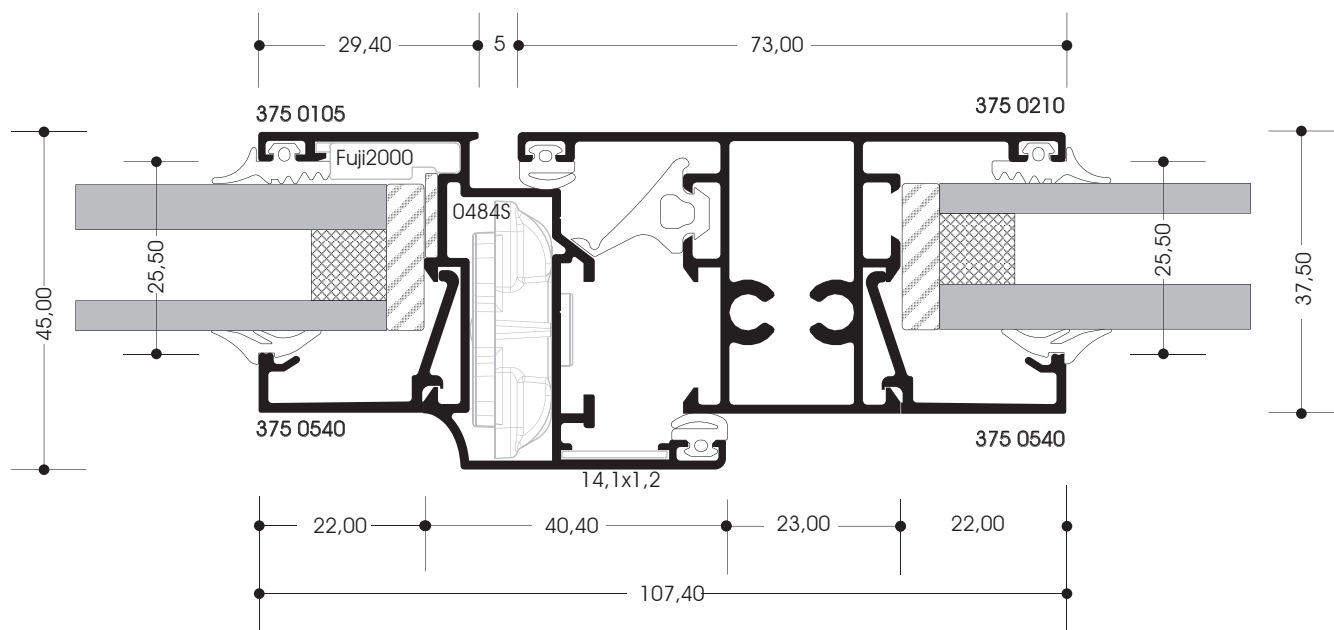

6.

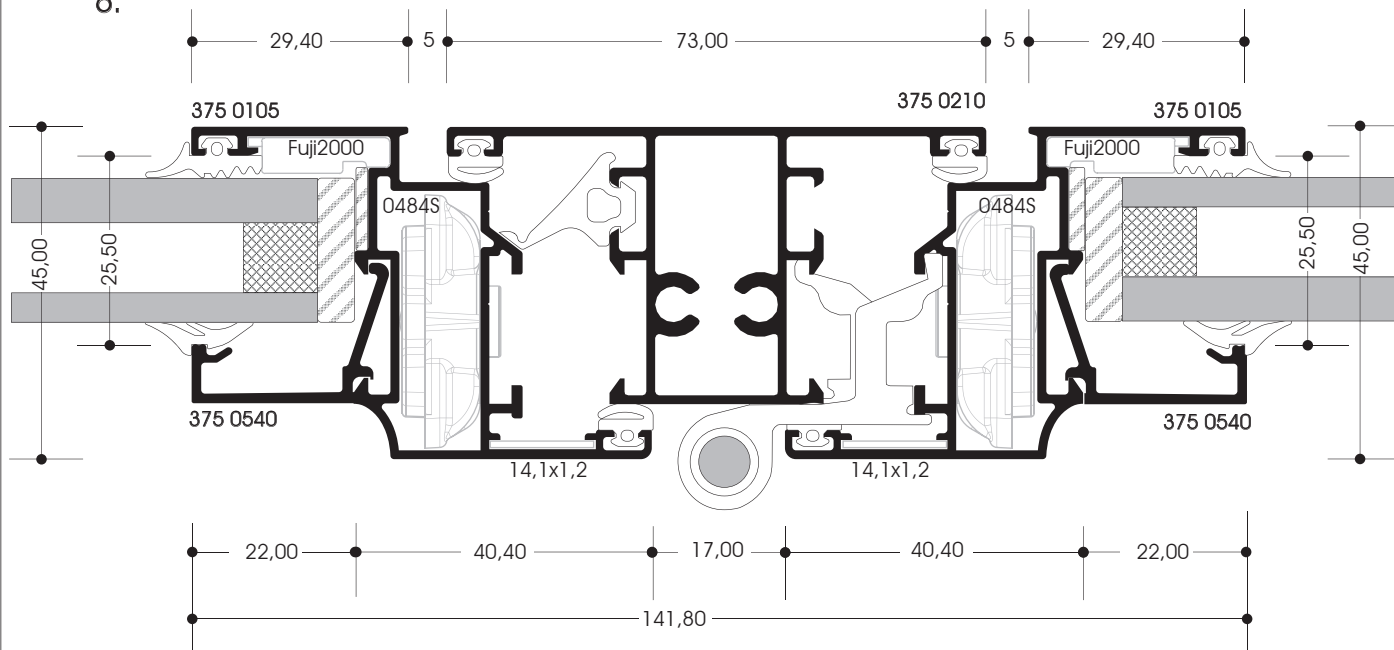

SECTIONS

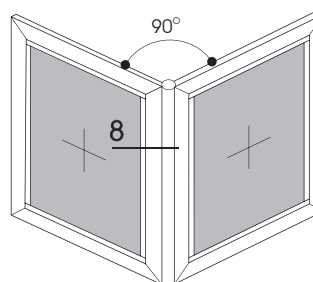
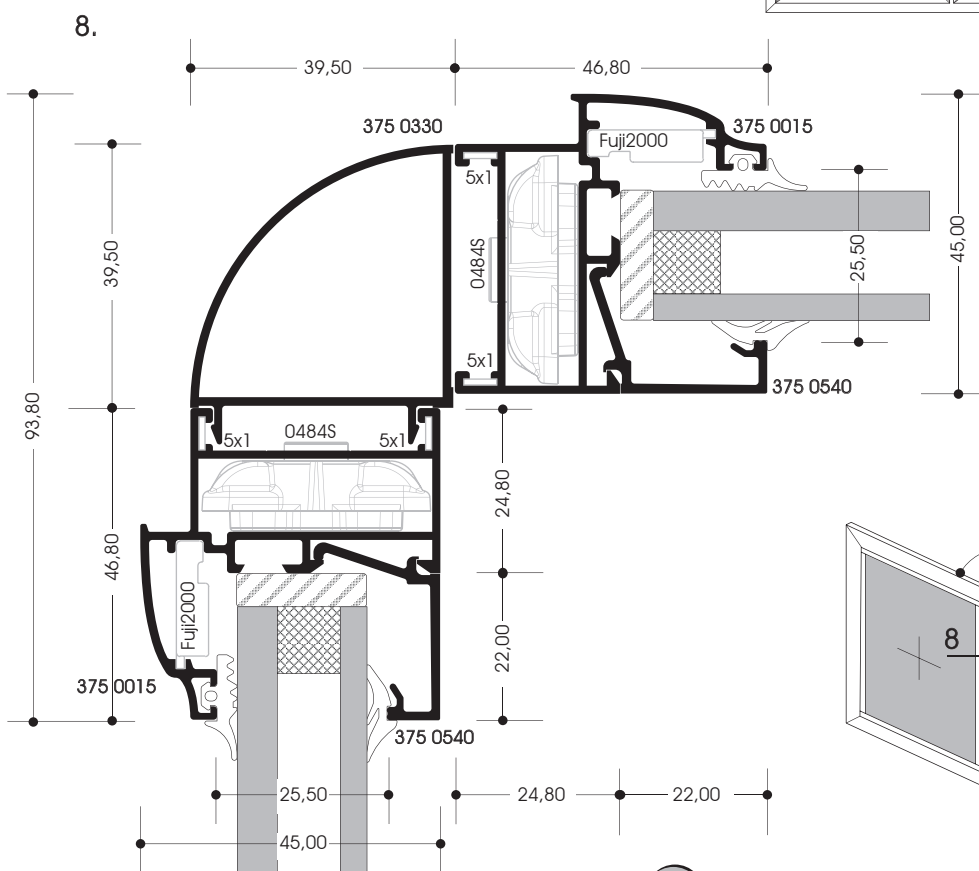
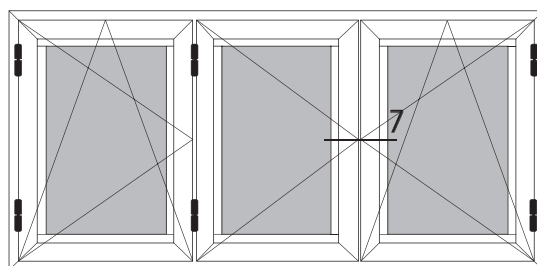
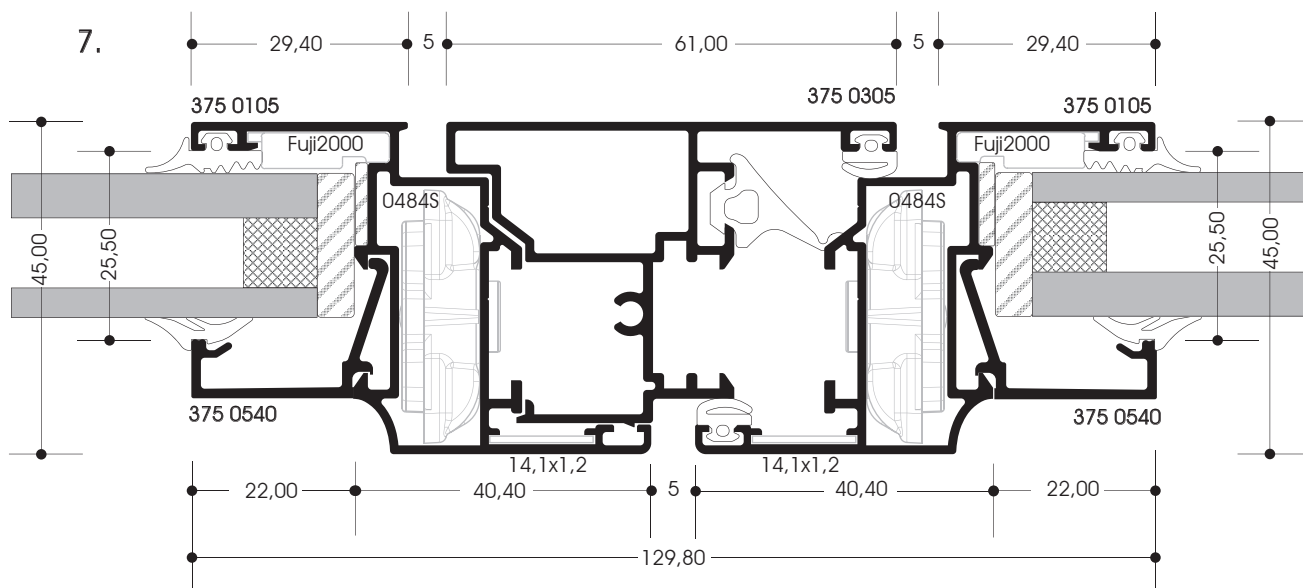

SECTIONS

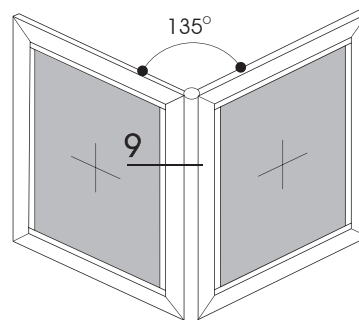
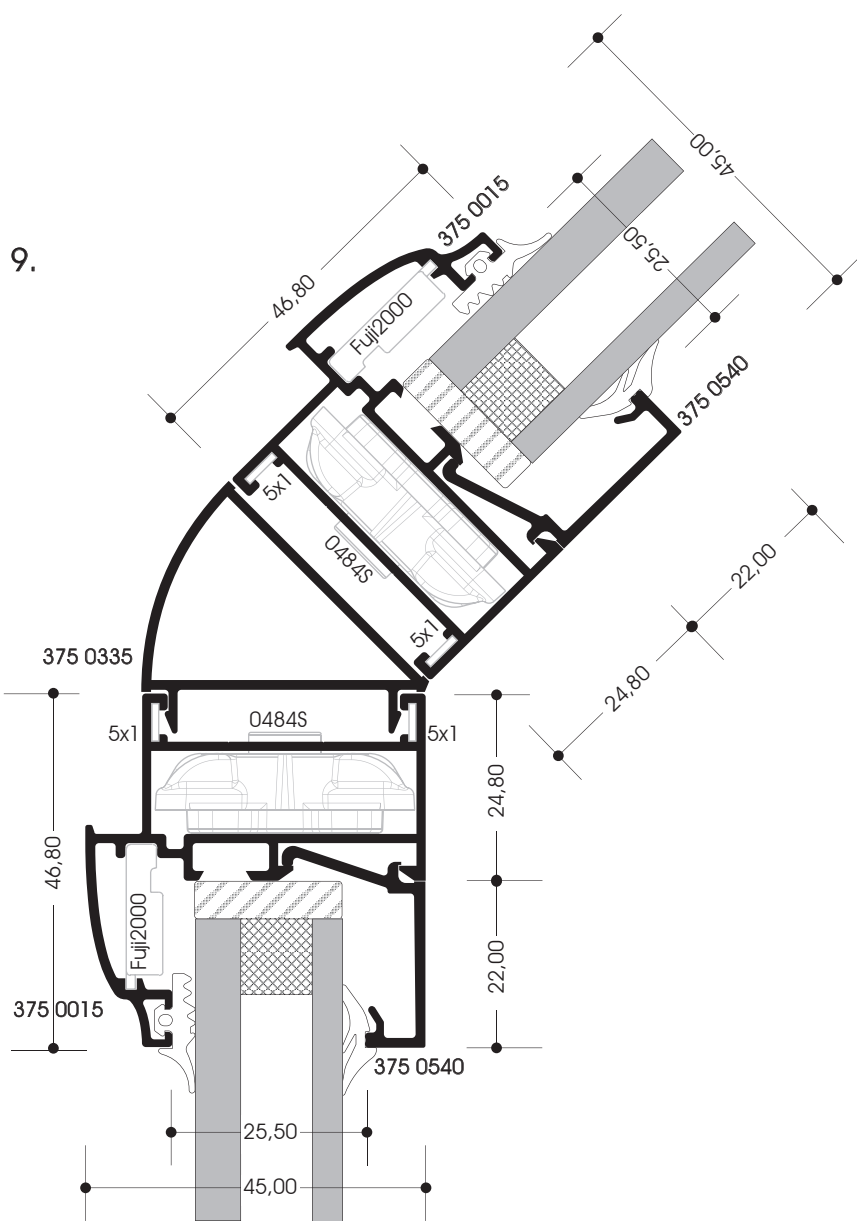

SECTIONS

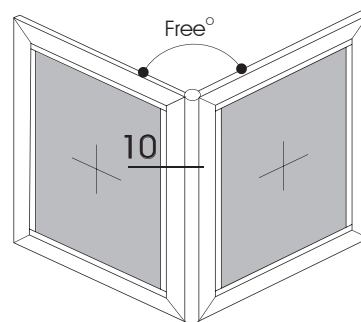
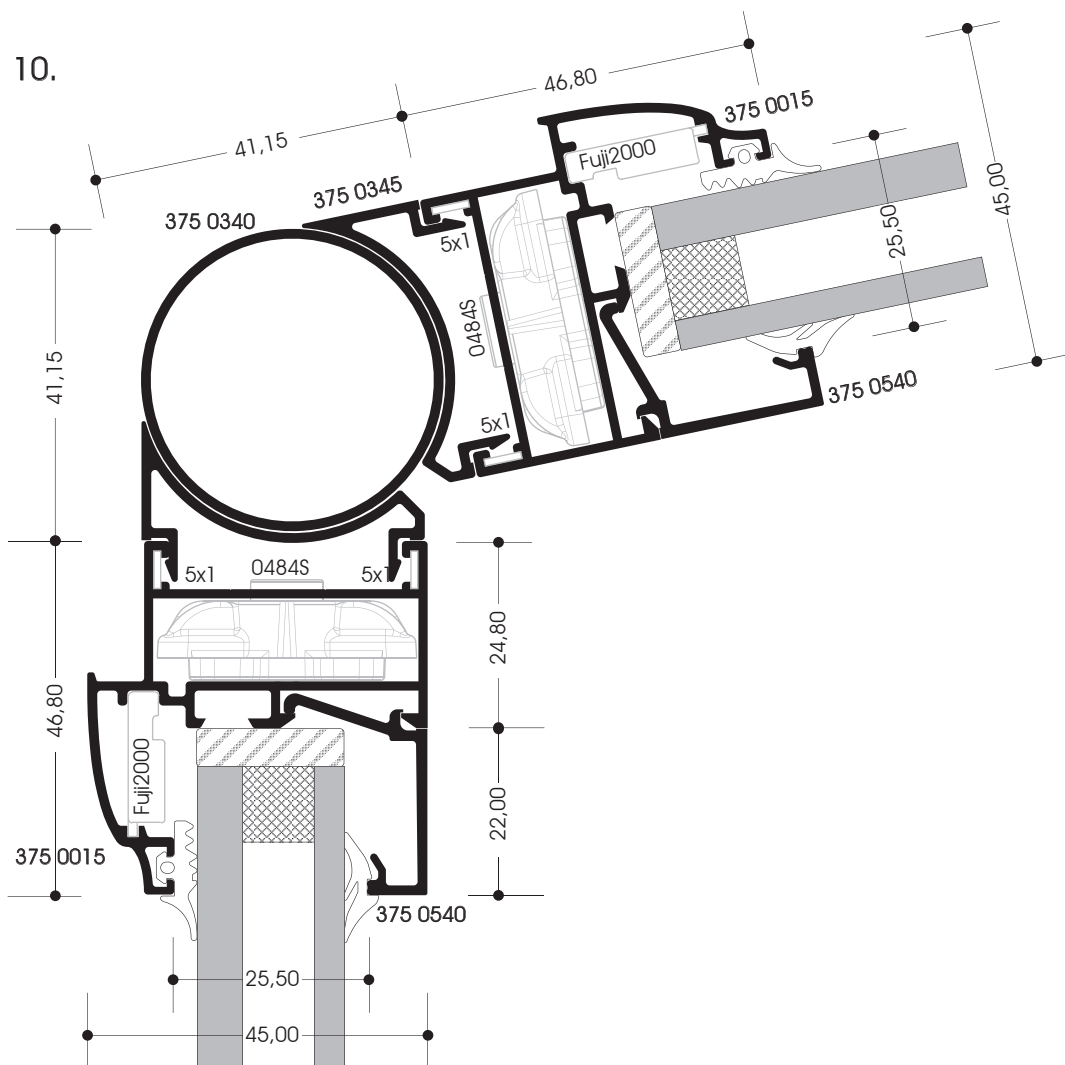

SECTIONS

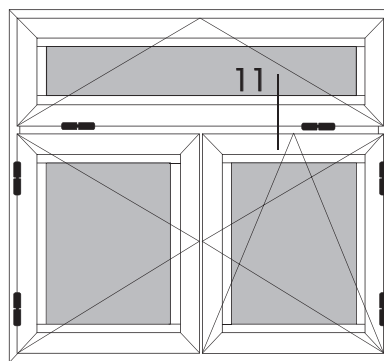
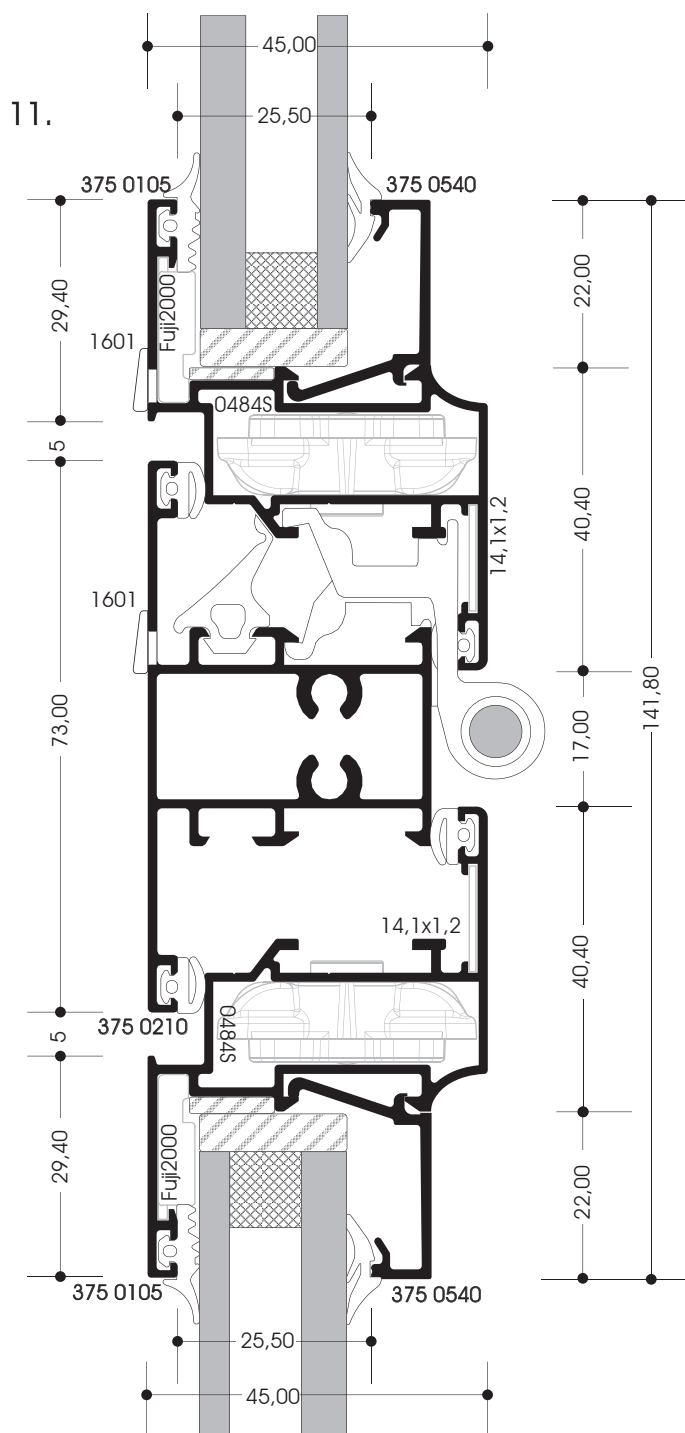

SECTIONS

13.

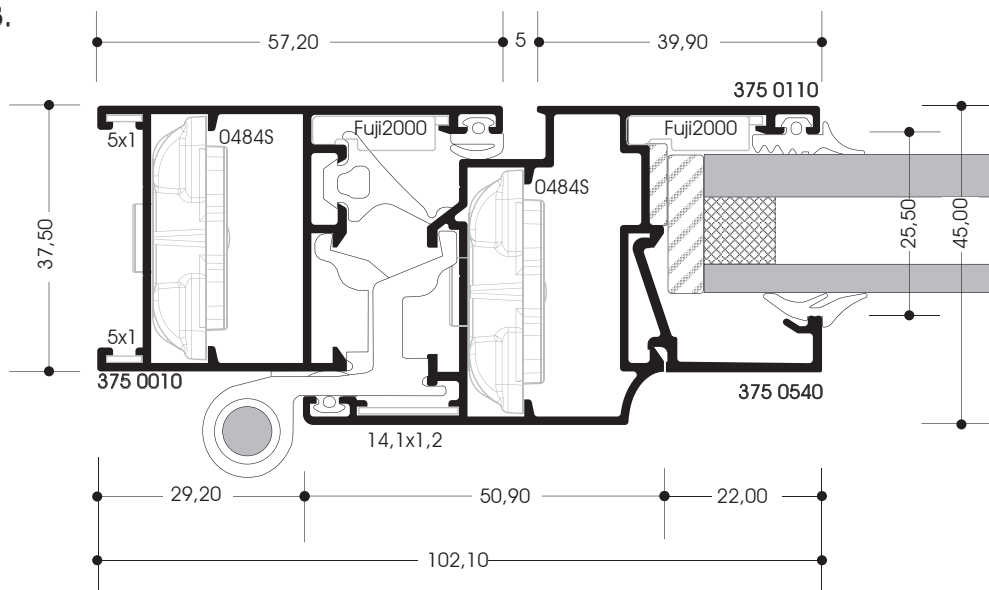

12.

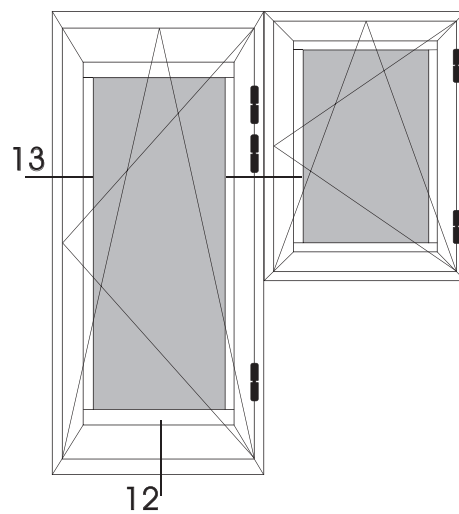
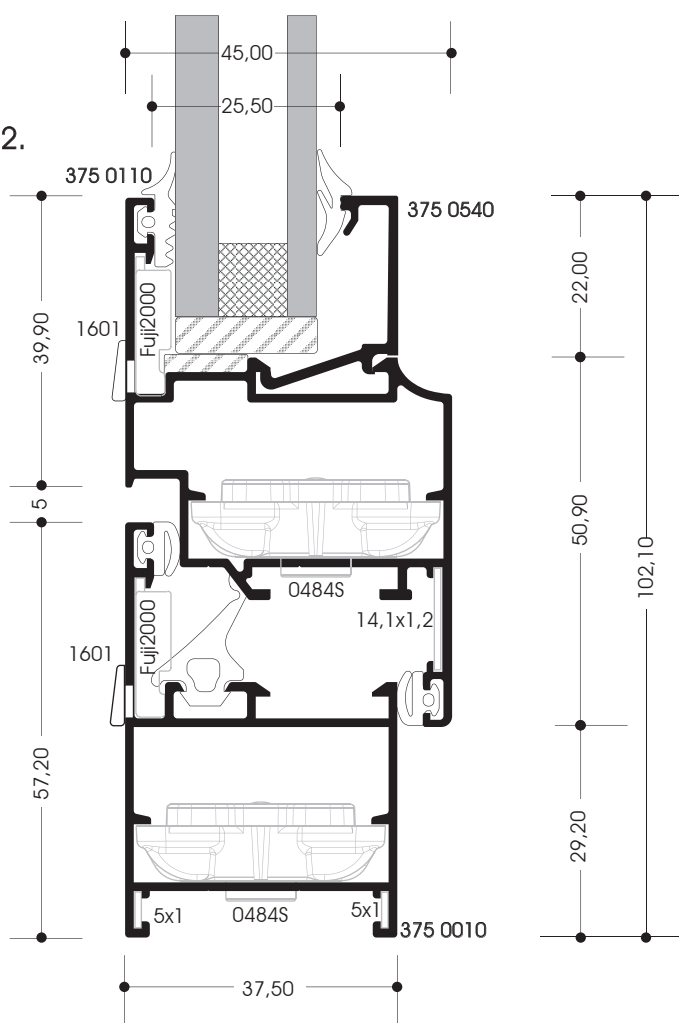

SECTIONS

13a.

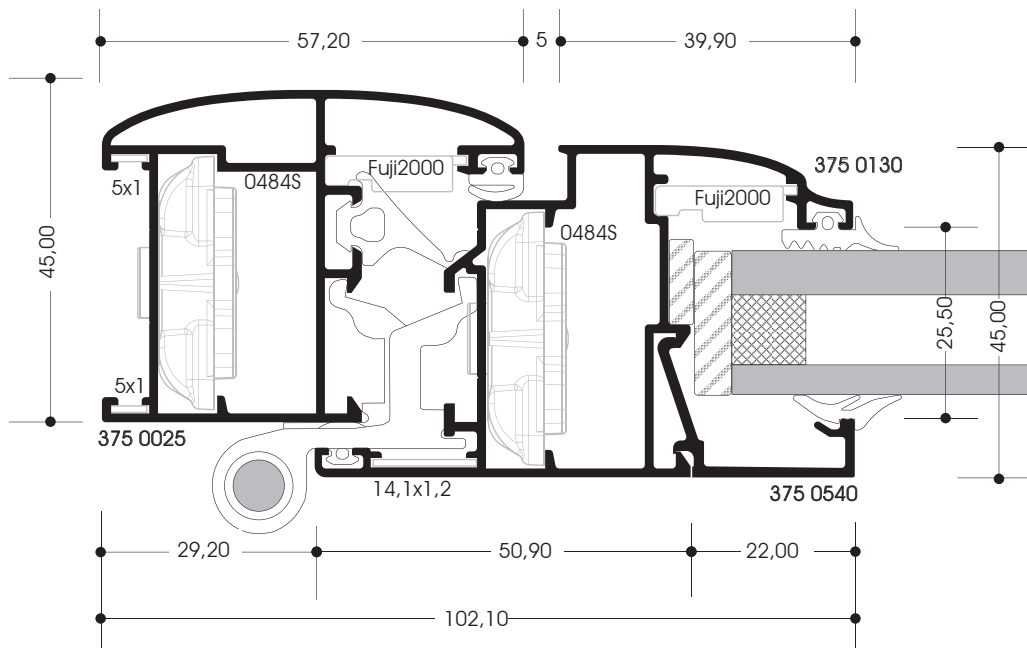

12a.

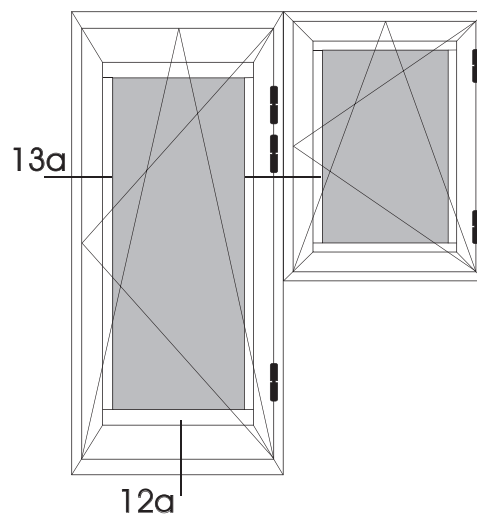
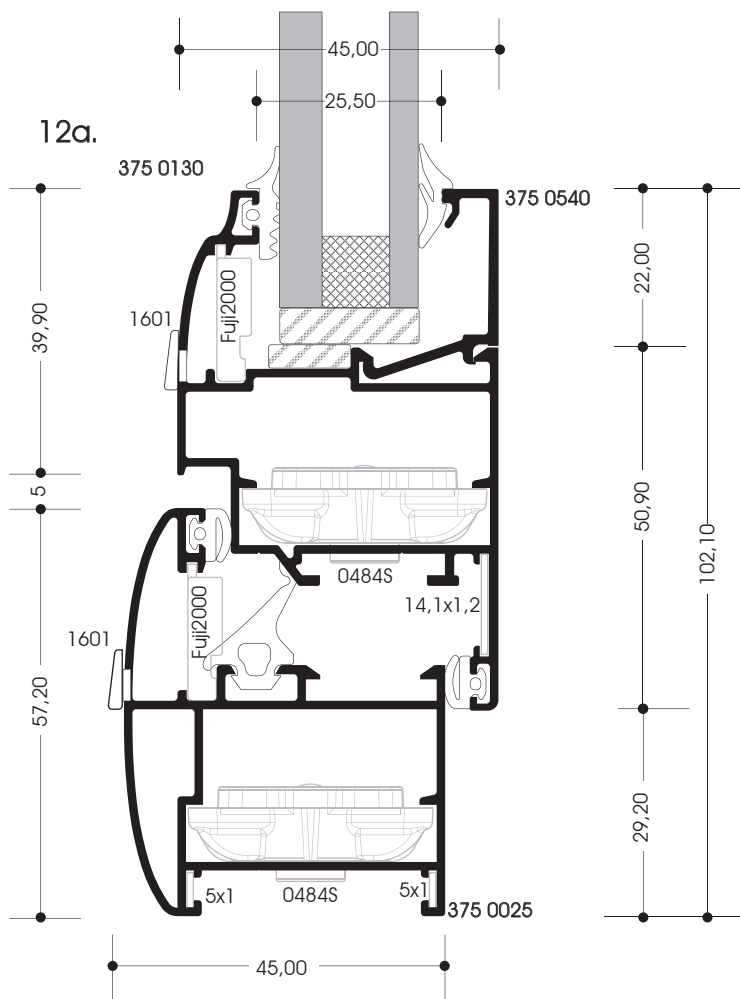

SECTIONS

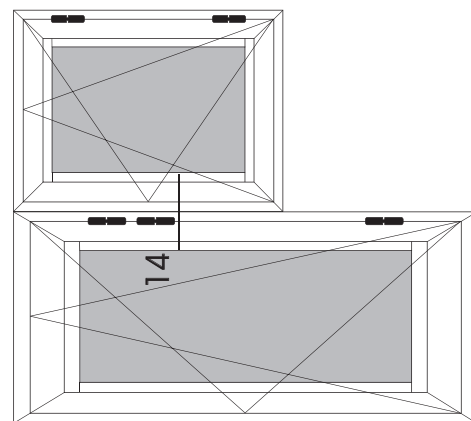
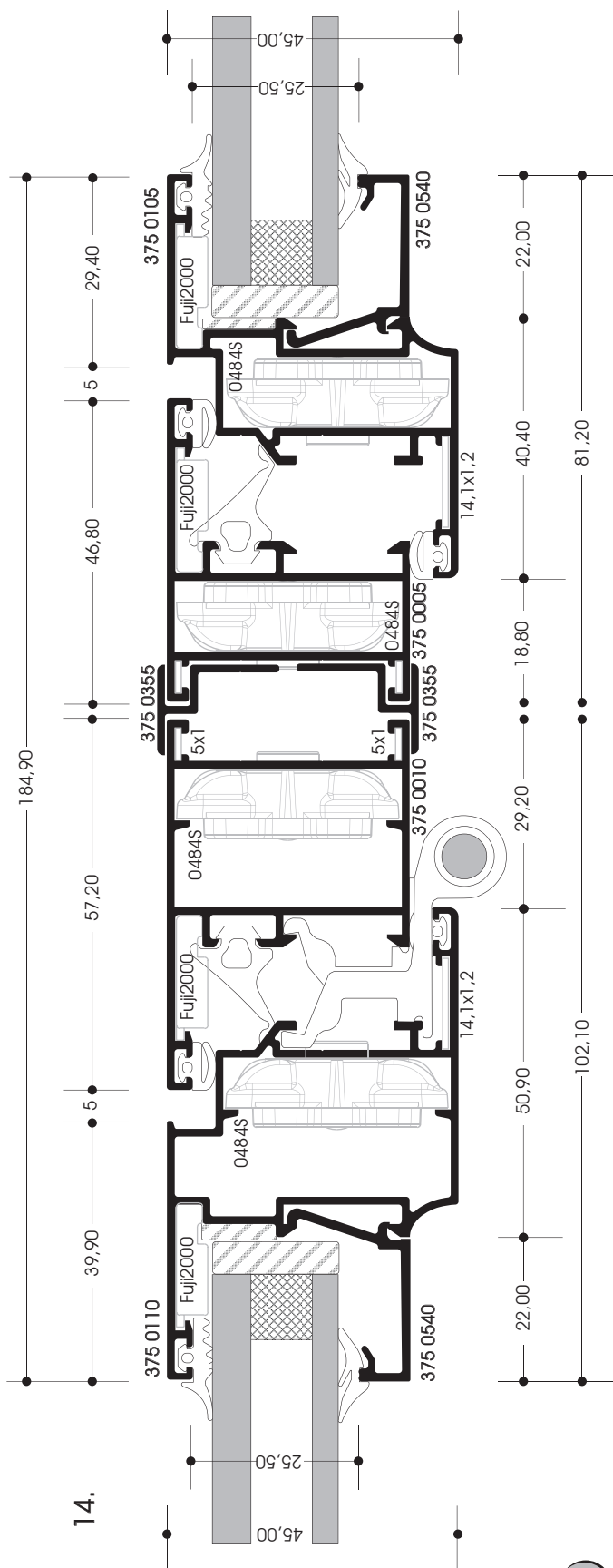

SECTIONS

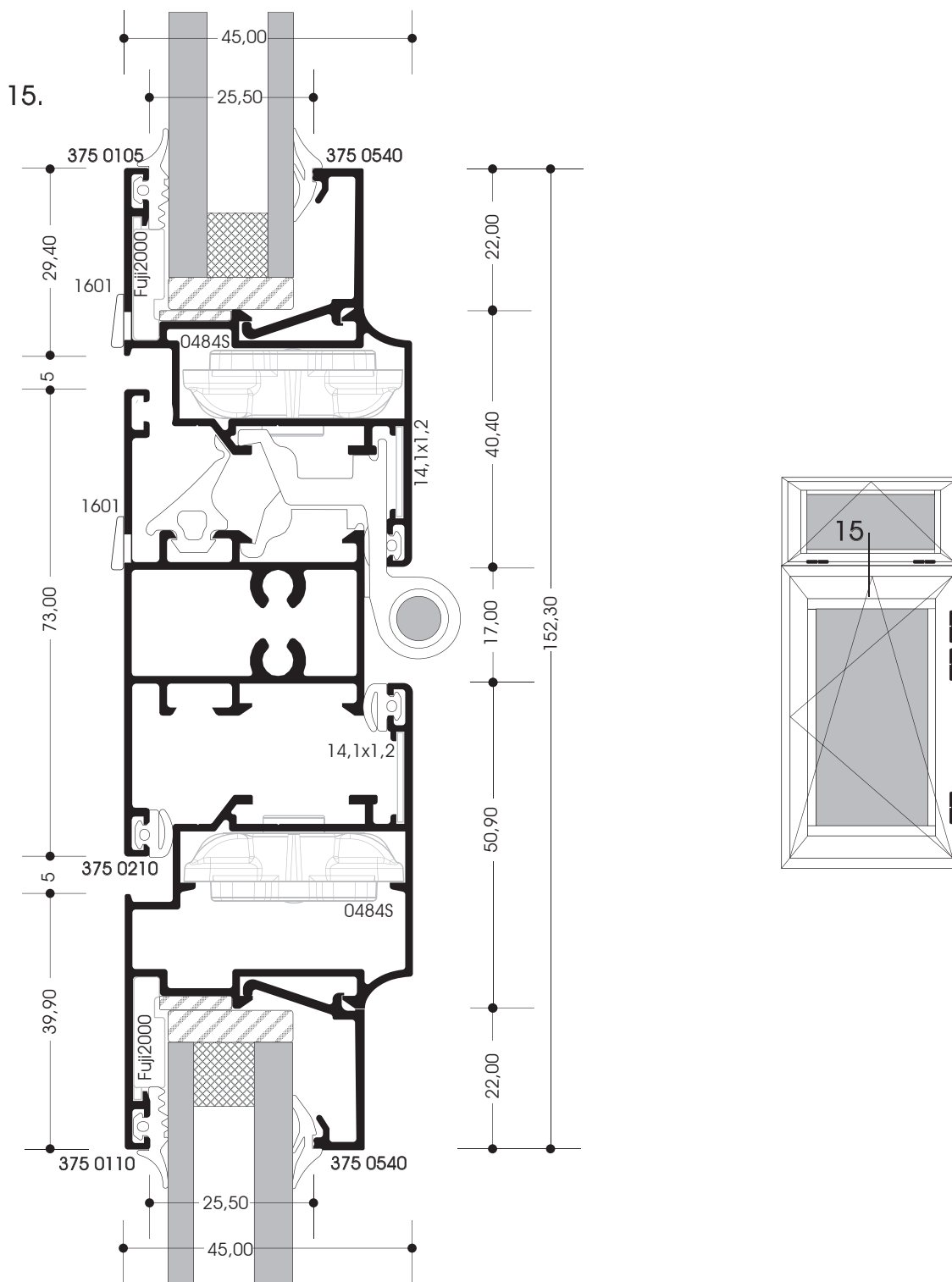

SECTIONS

16.

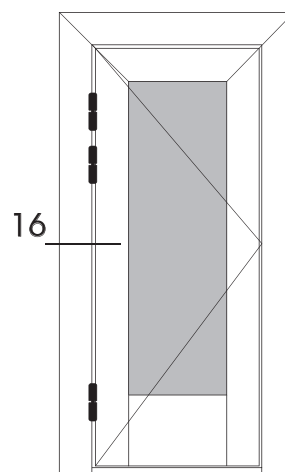
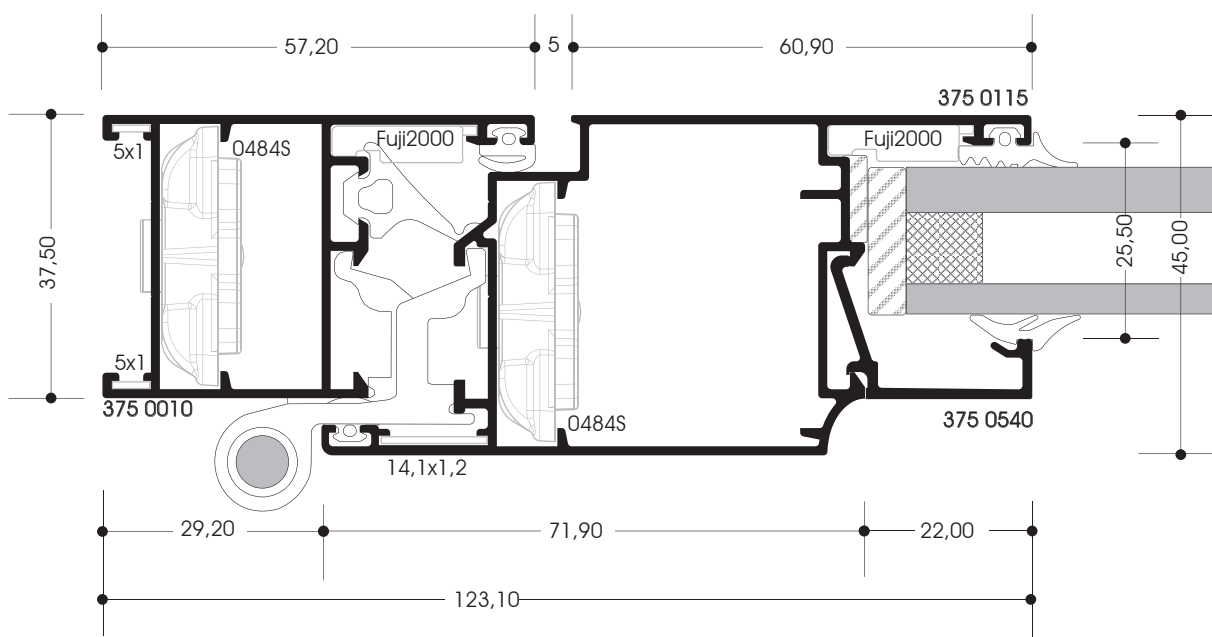

SECTIONS

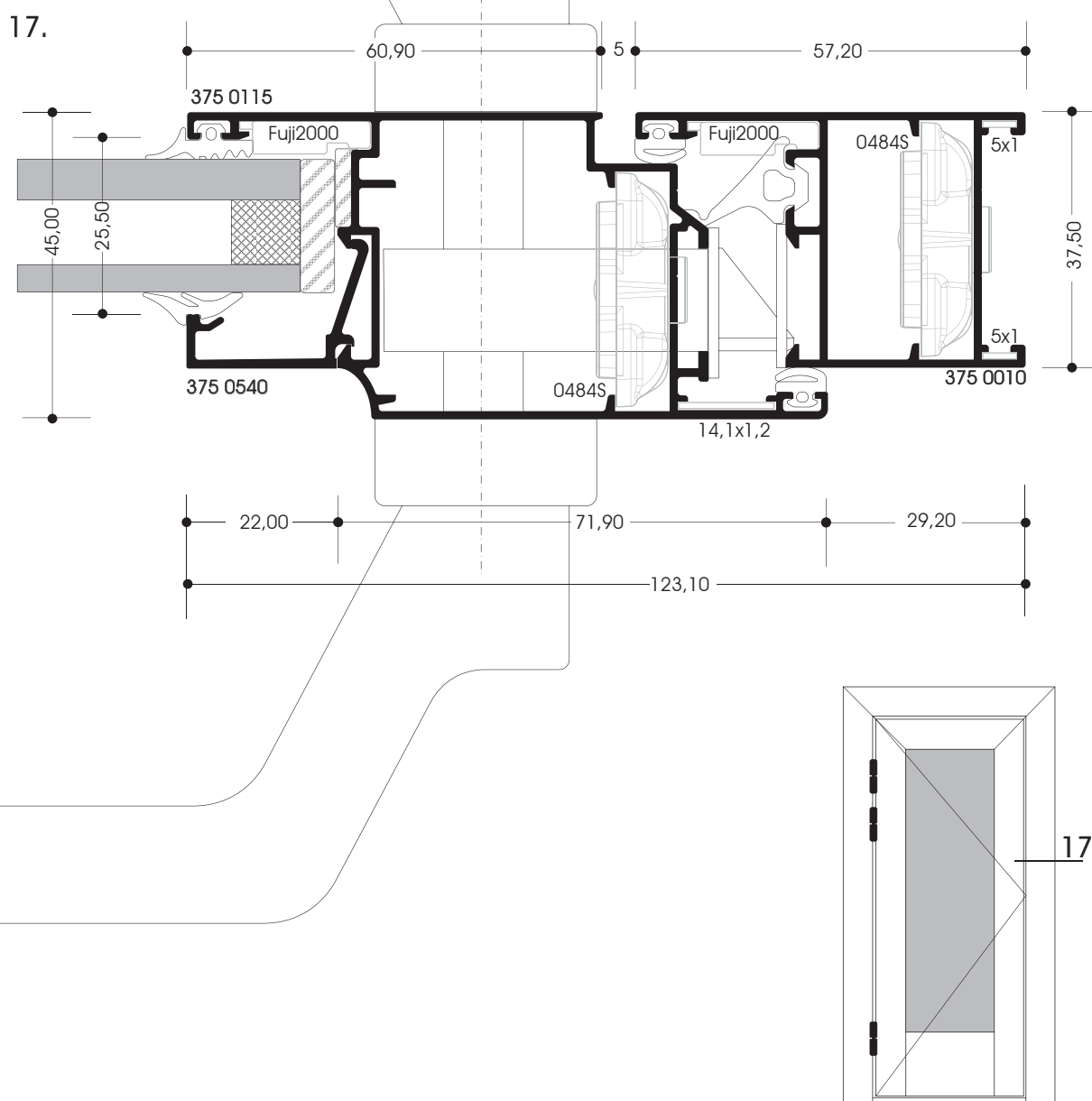

SECTIONS

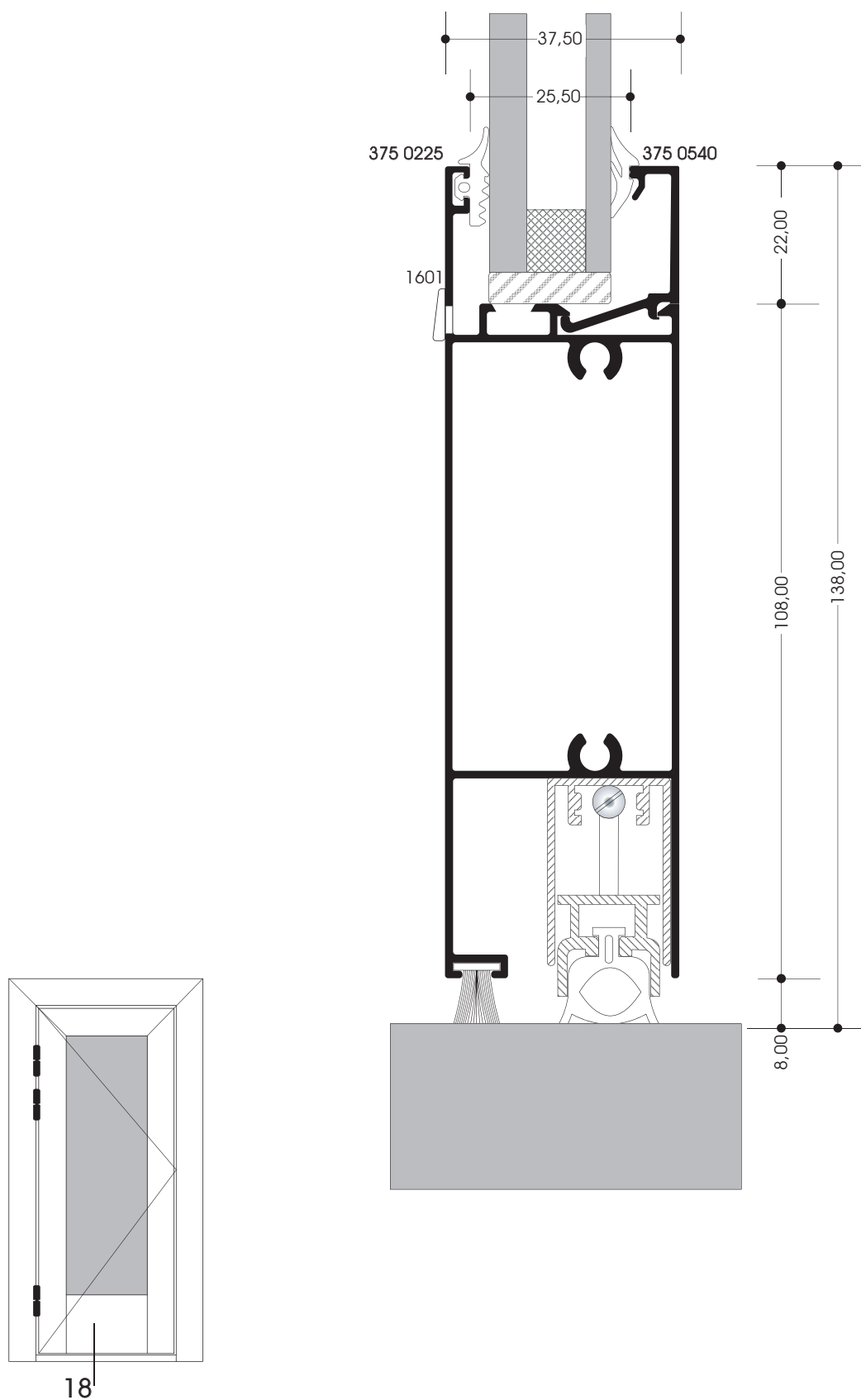

SECTIONS

19.

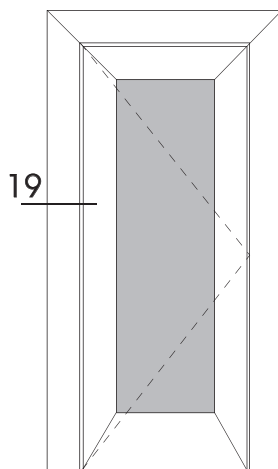
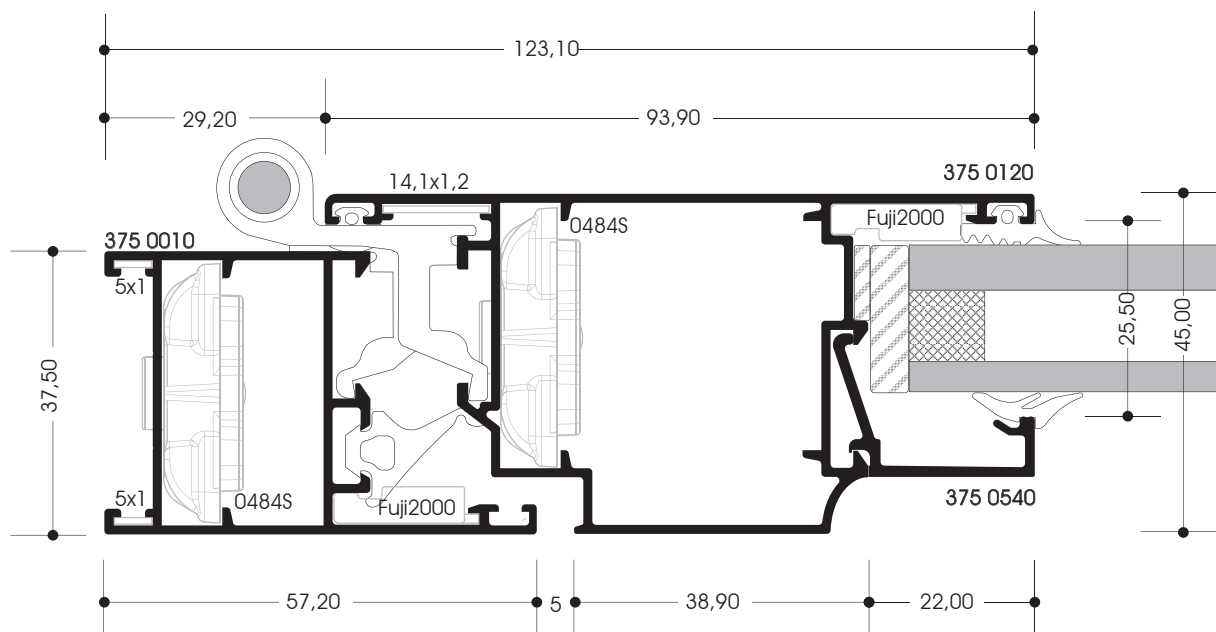

SECTIONS

20.

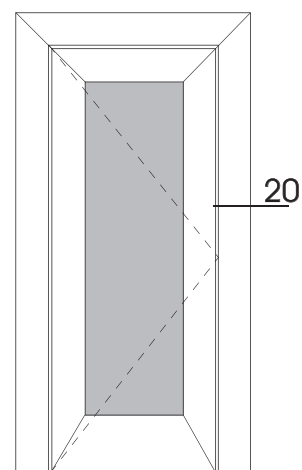
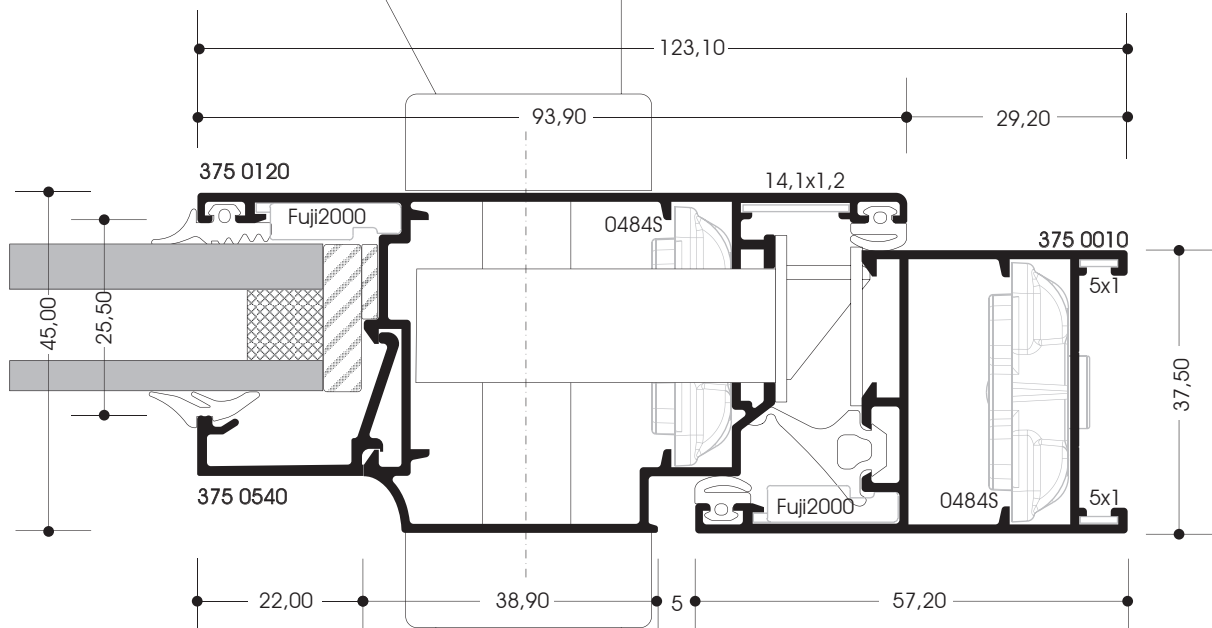

SECTIONS

21.

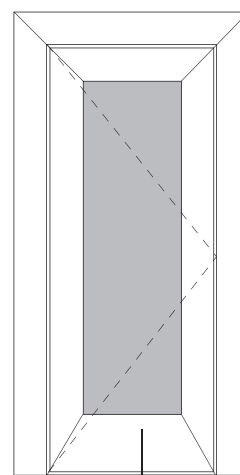
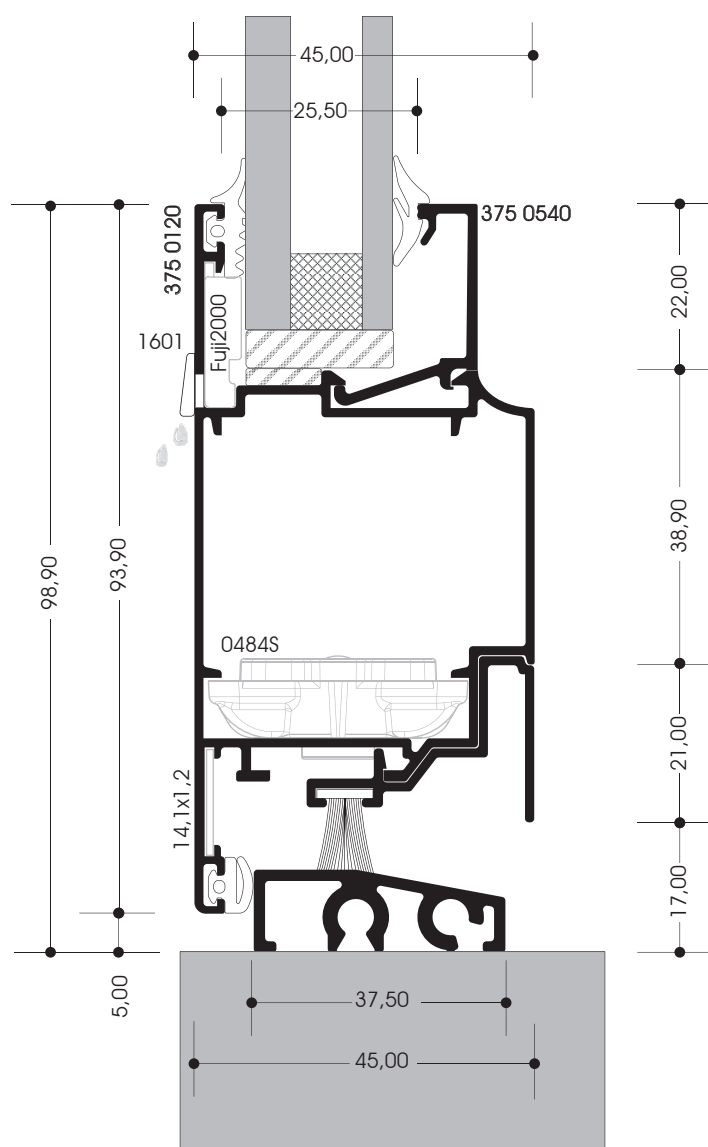

SECTIONS

22.

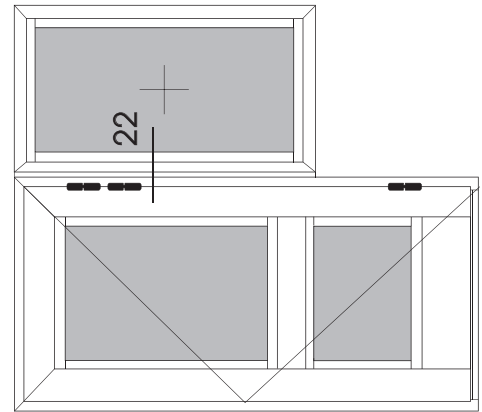
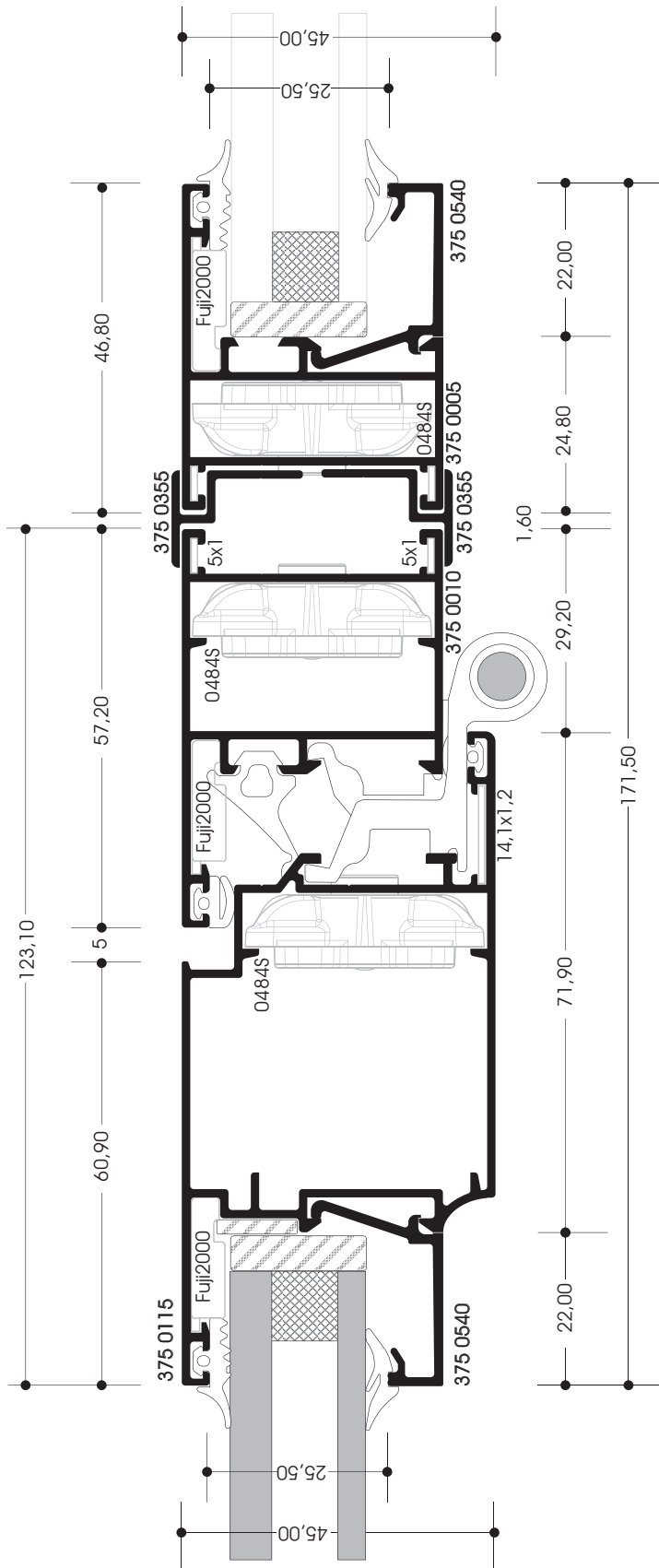

SECTIONS

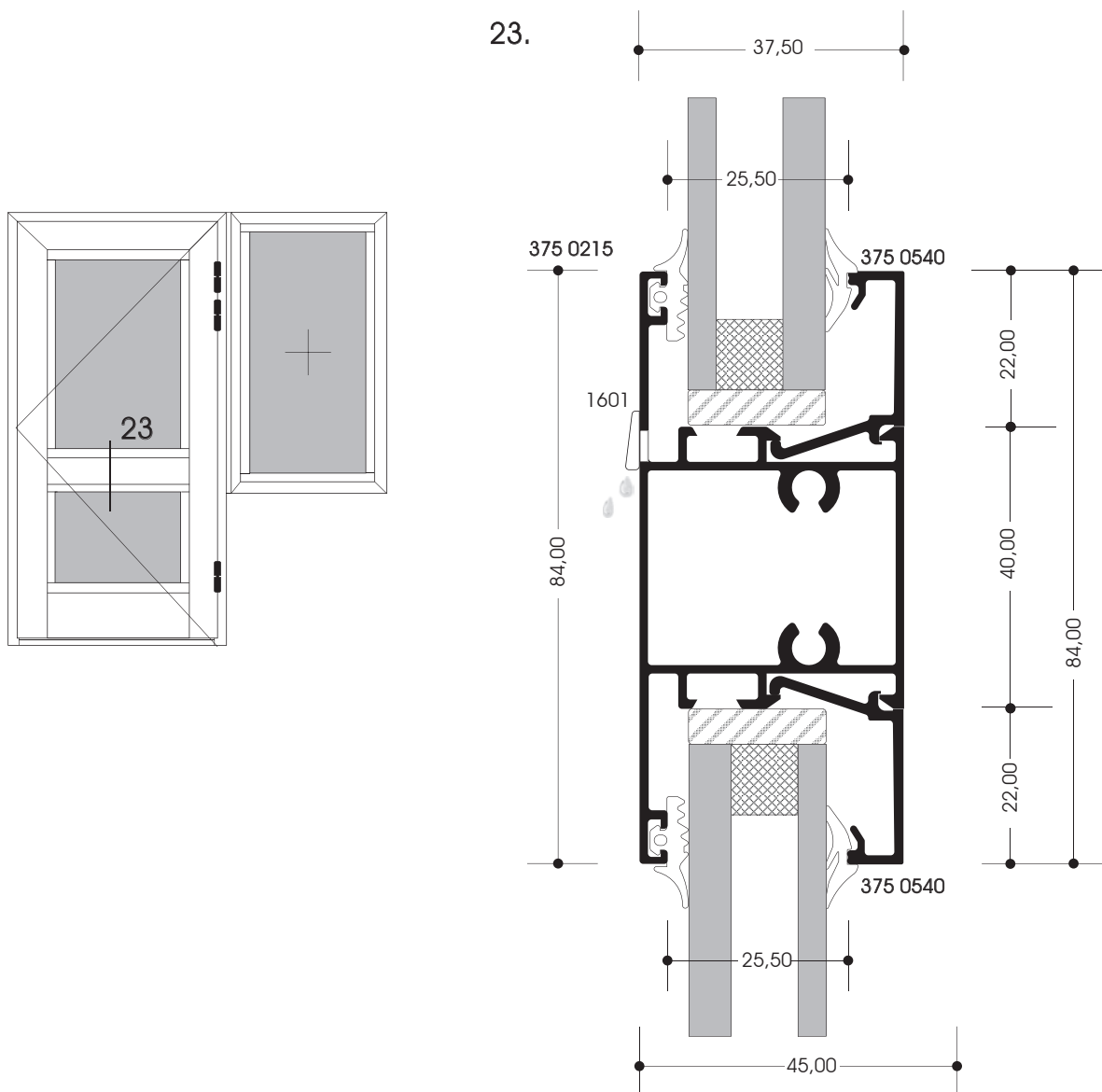

РАЗРЕЗИ

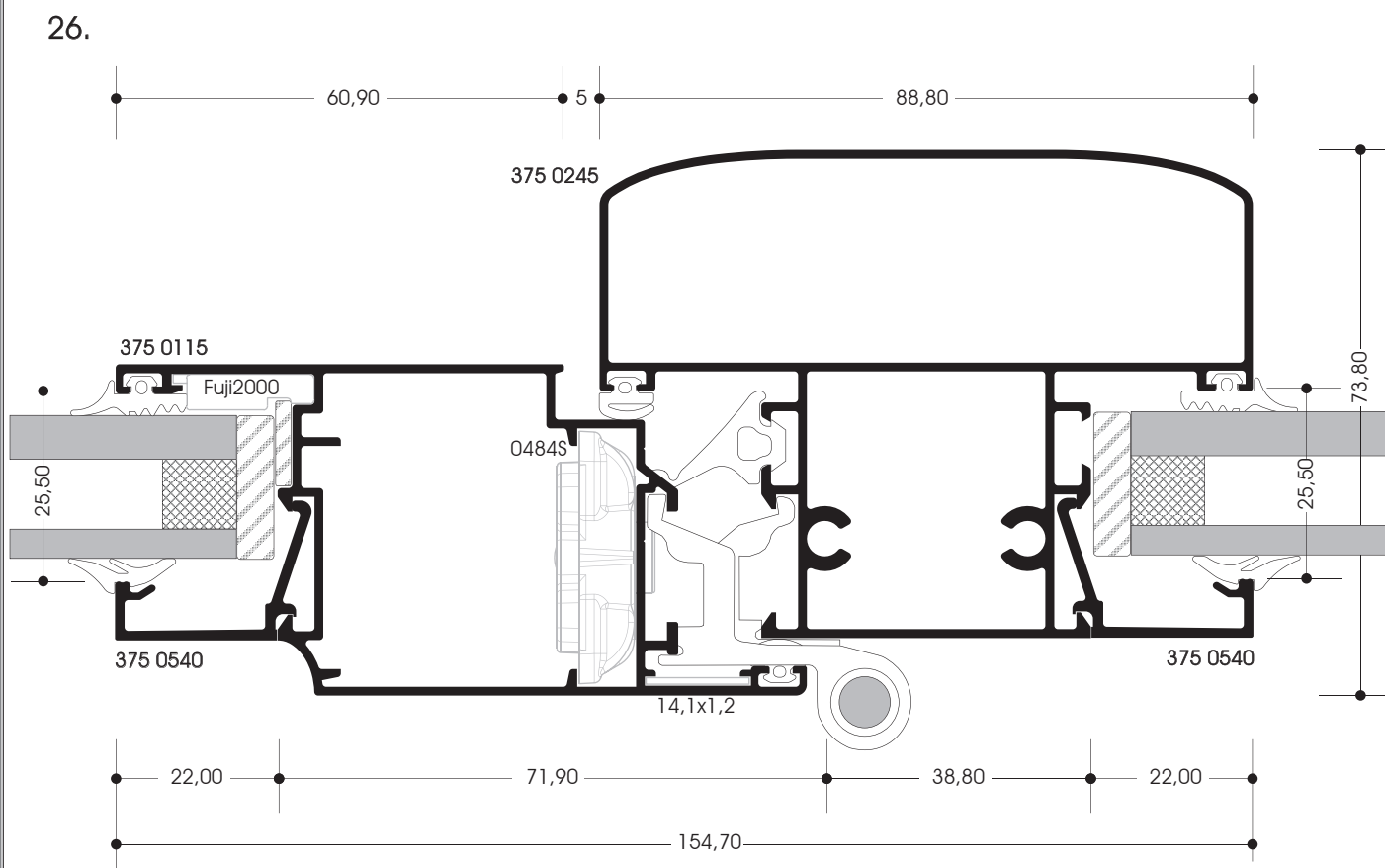
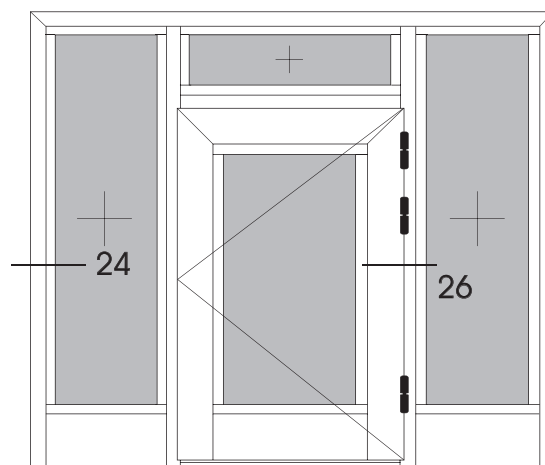
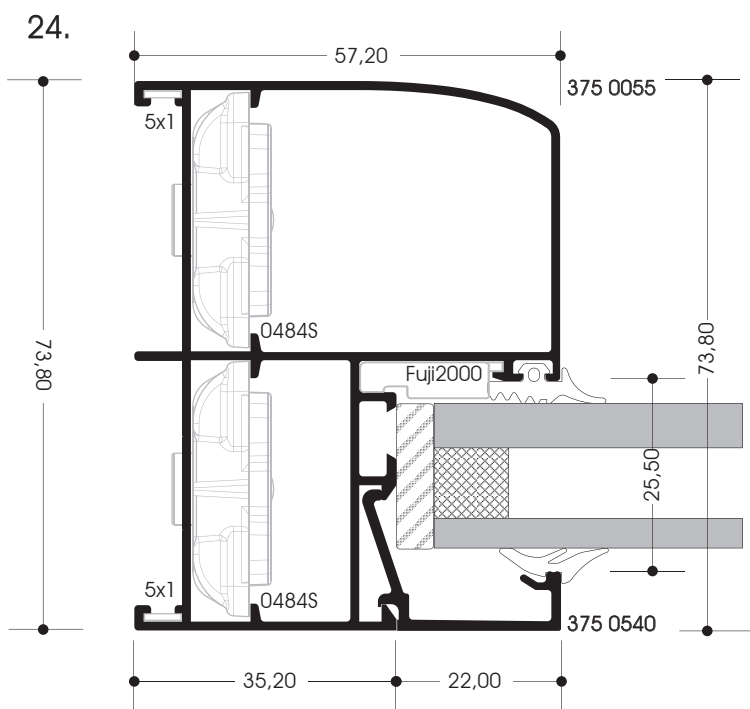

SECTIONS

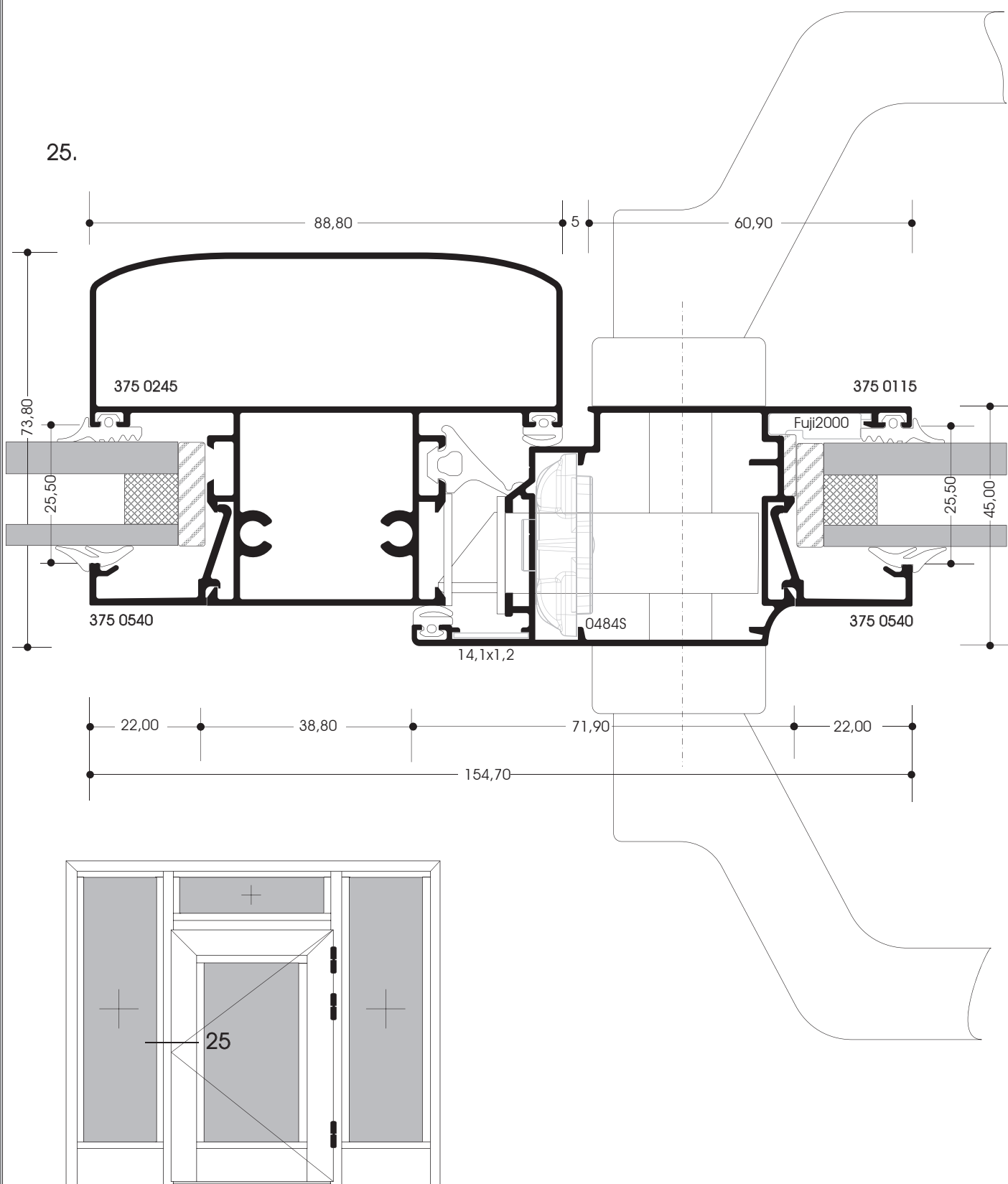

SECTIONS

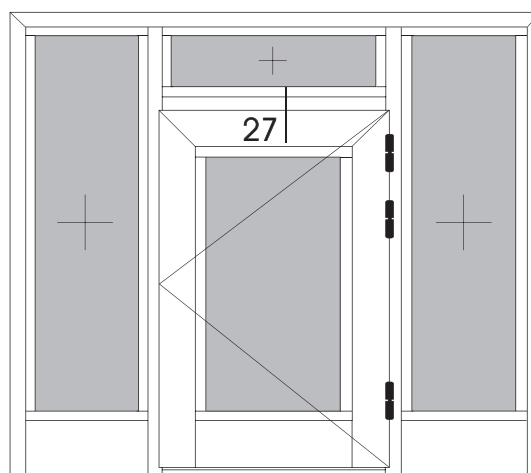
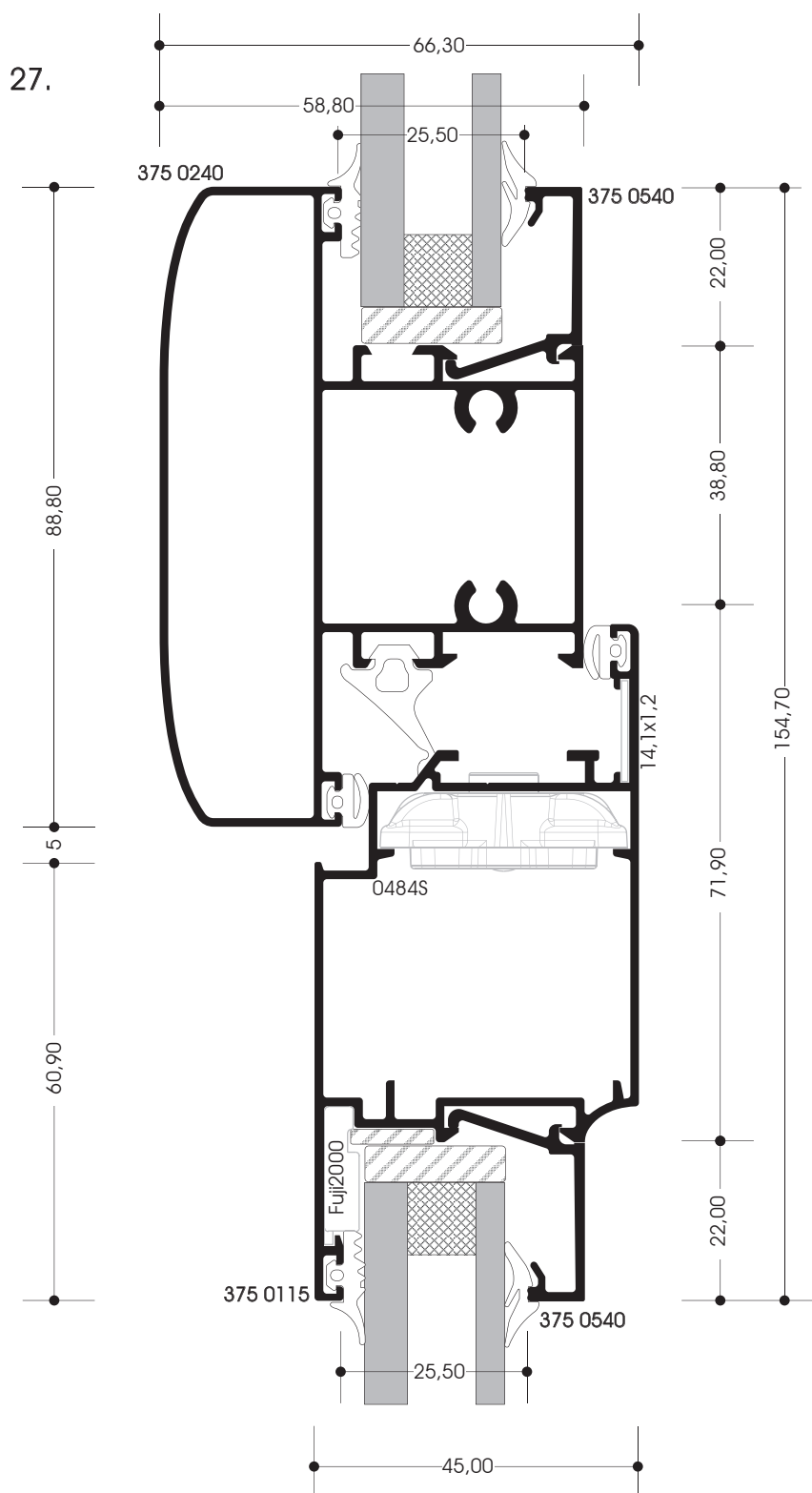

SECTIONS

28.

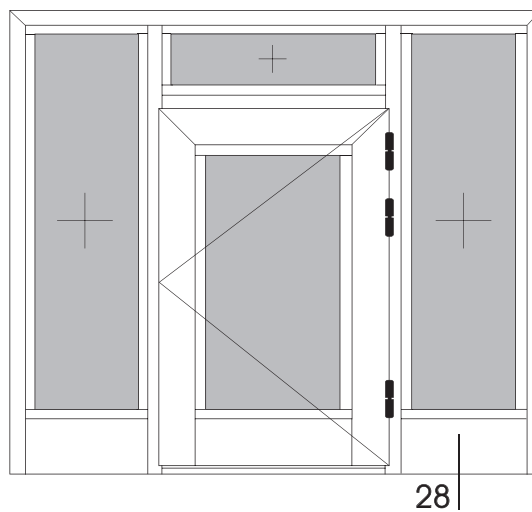
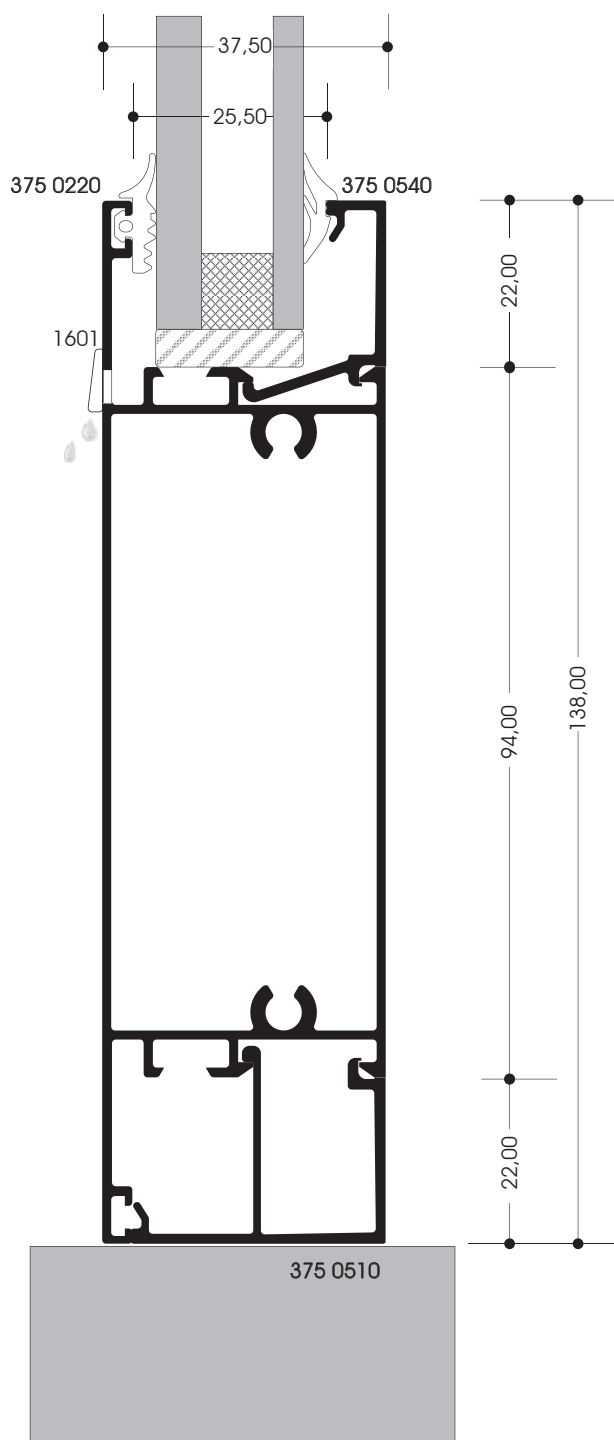

SECTIONS

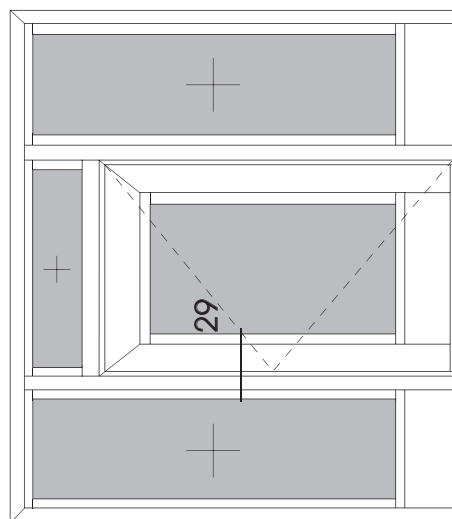
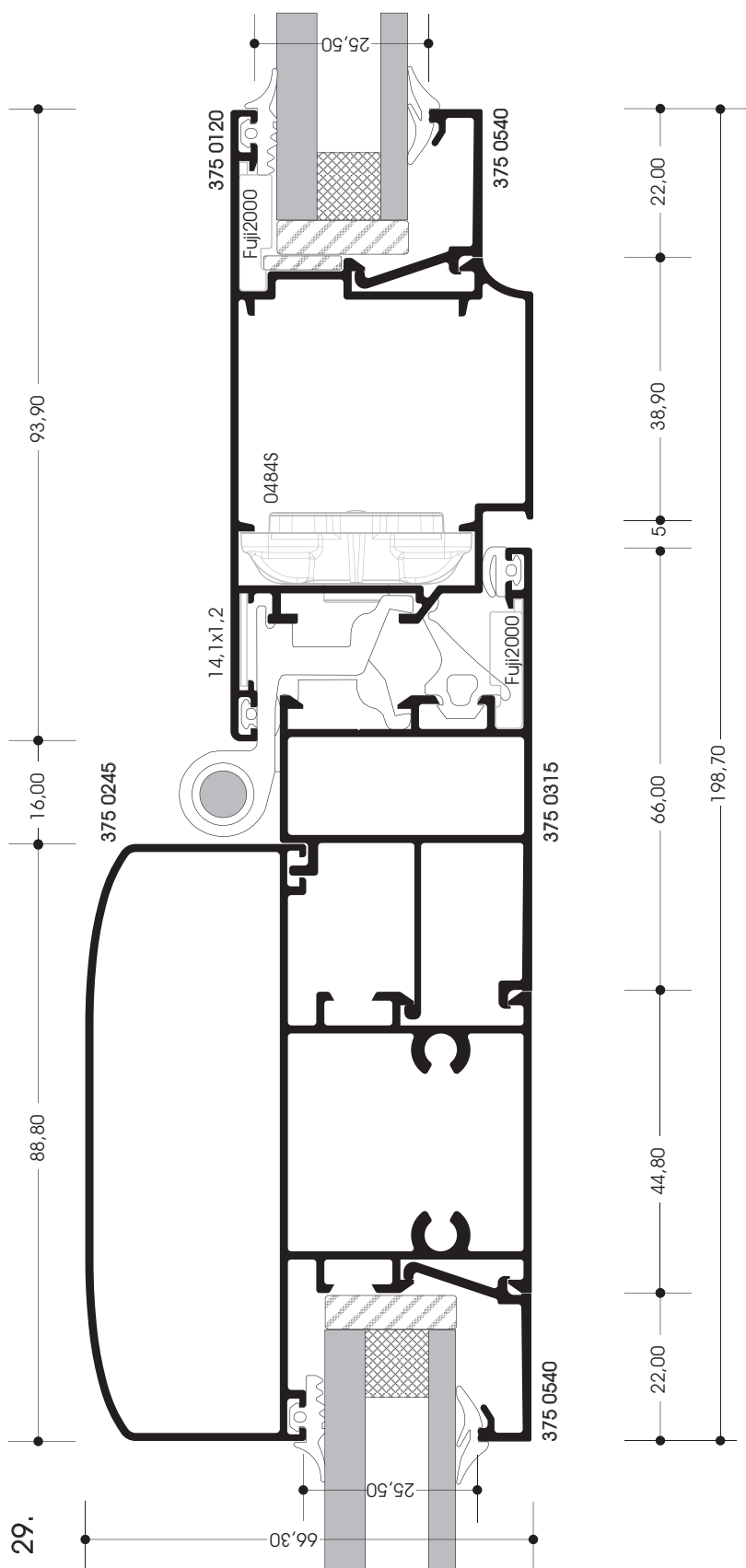

SECTIONS

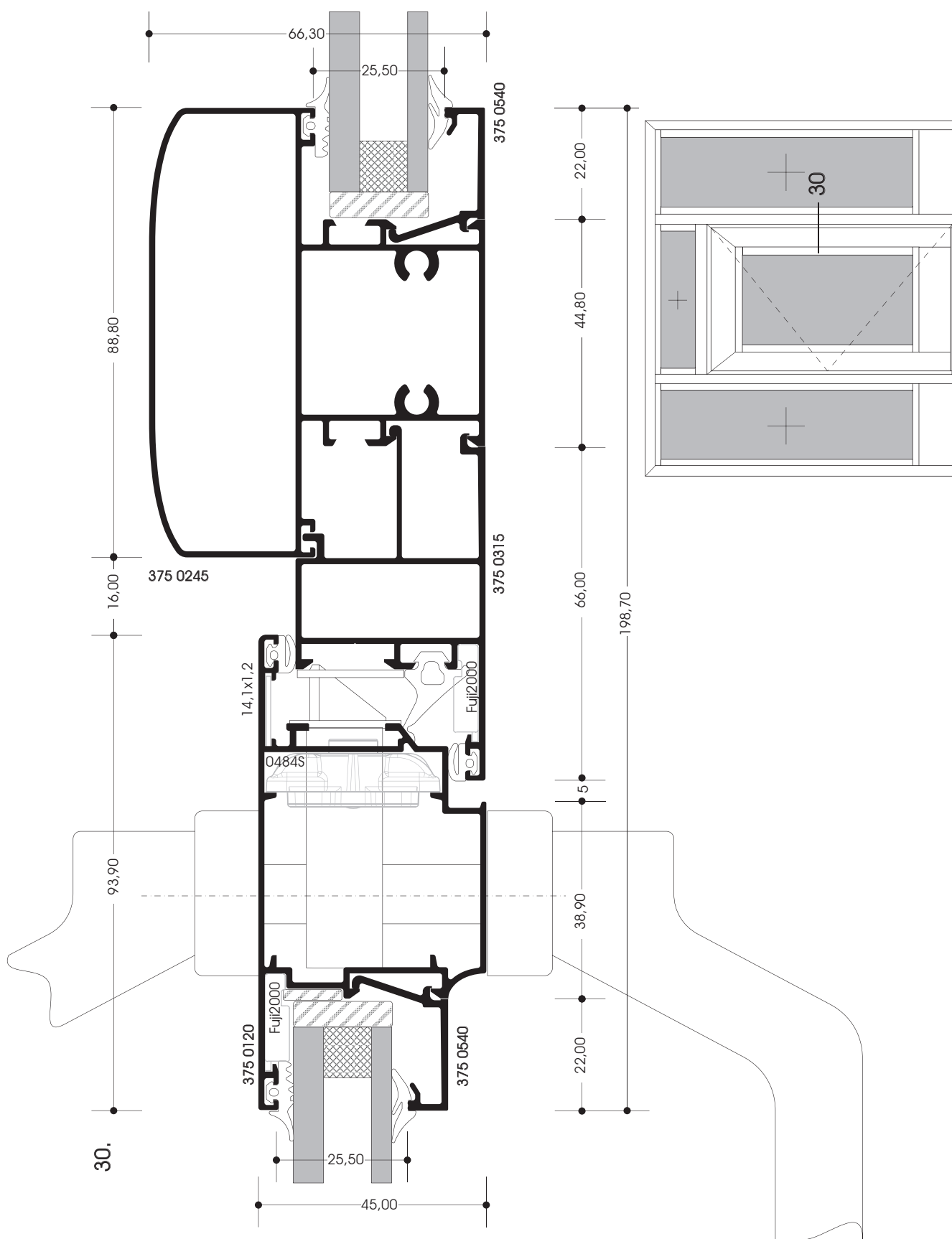

SECTIONS

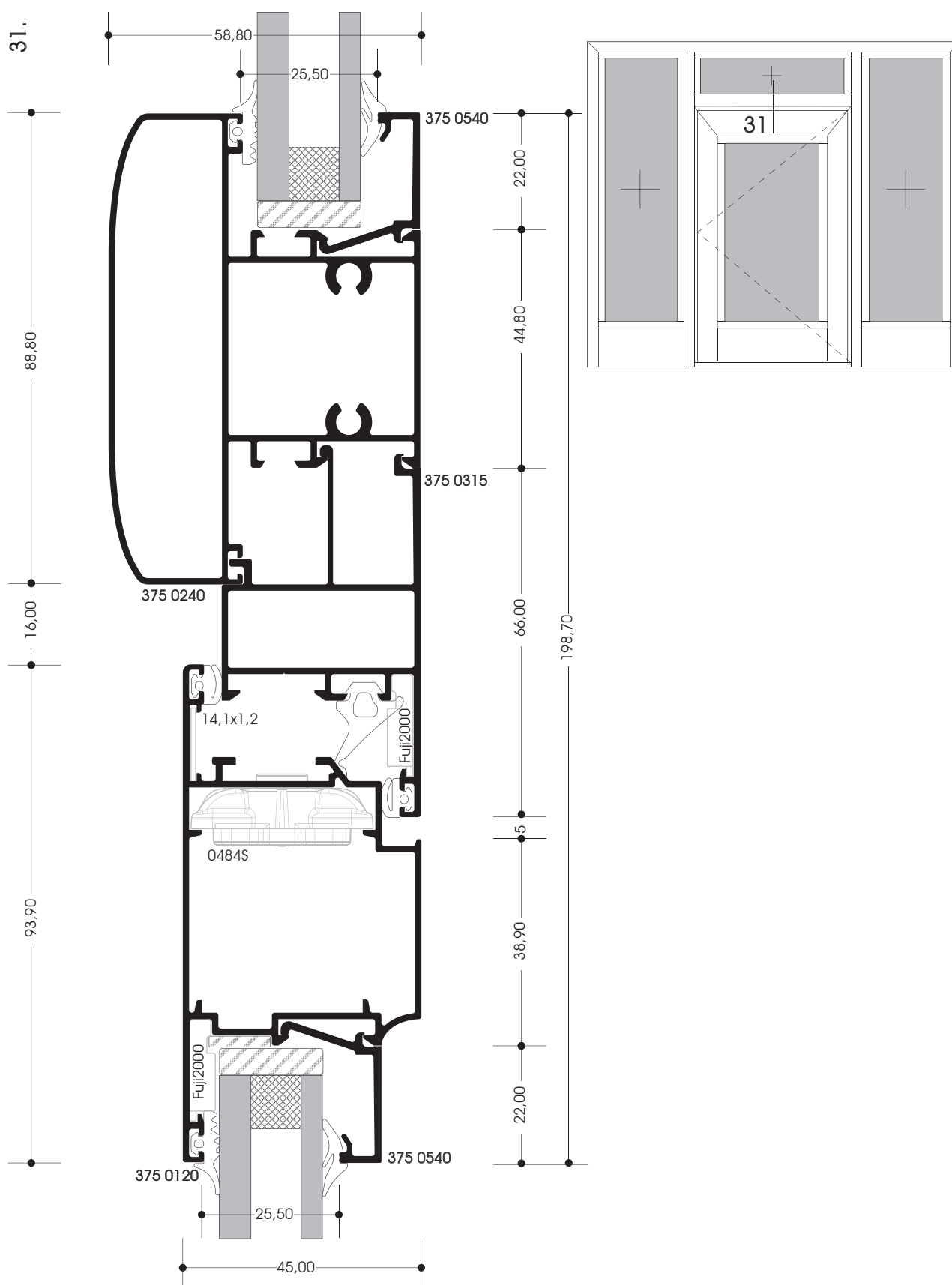

SECTIONS

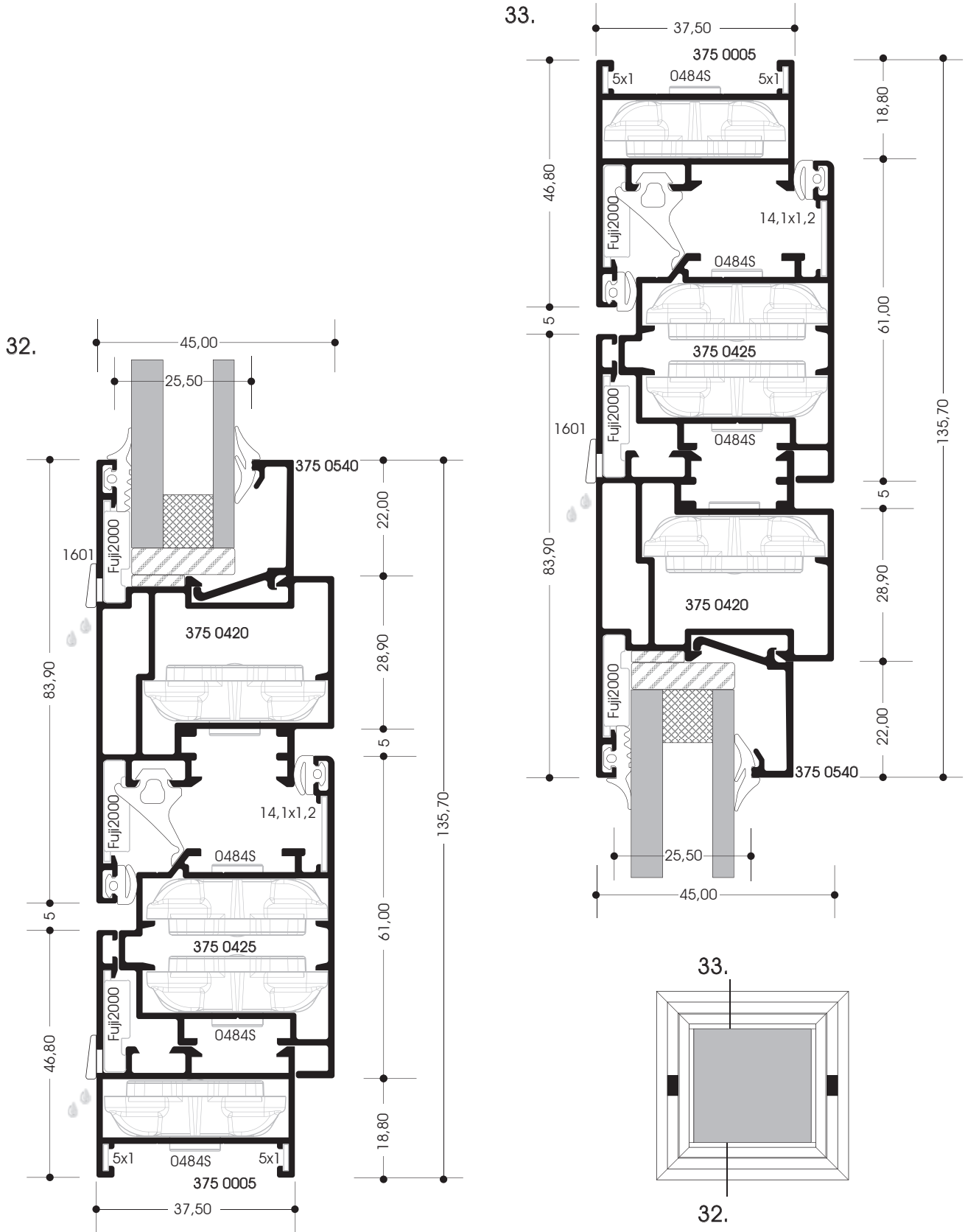

SECTIONS

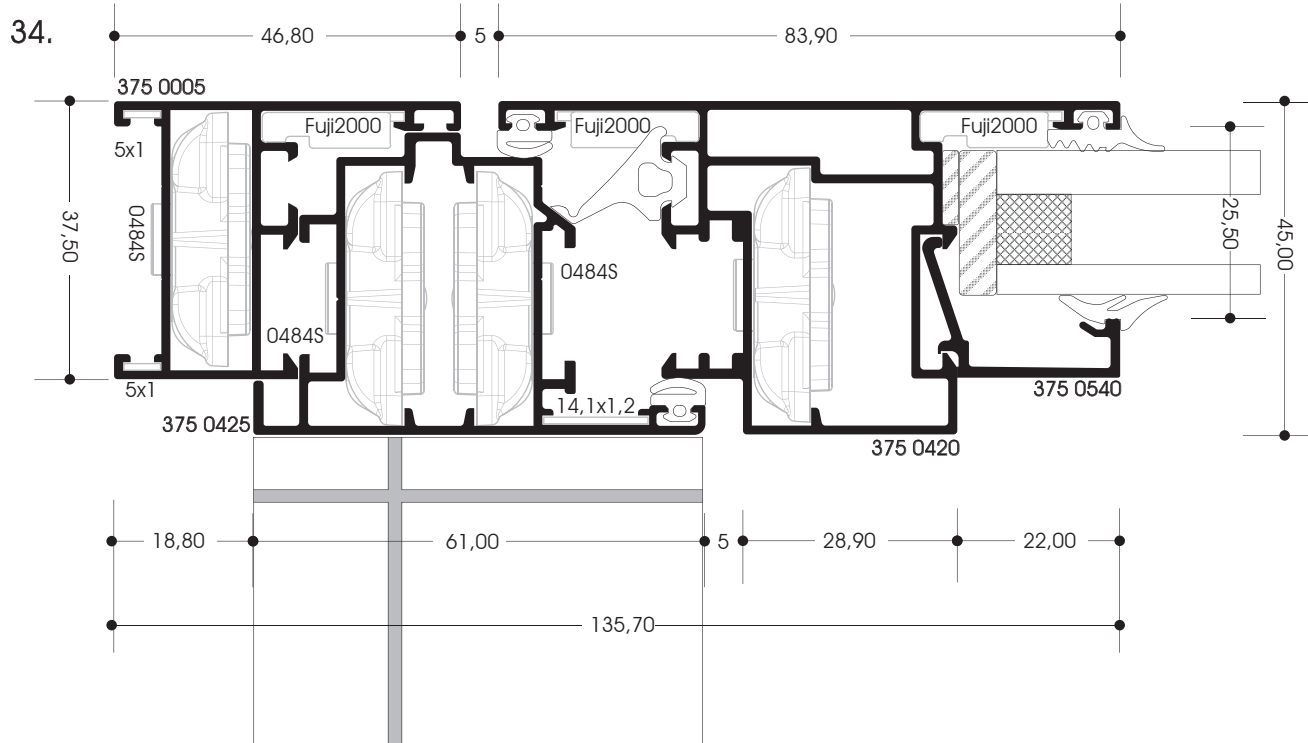
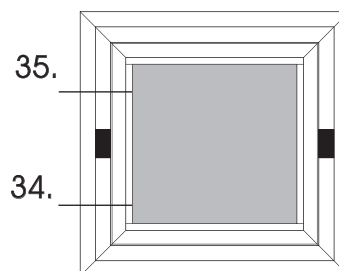
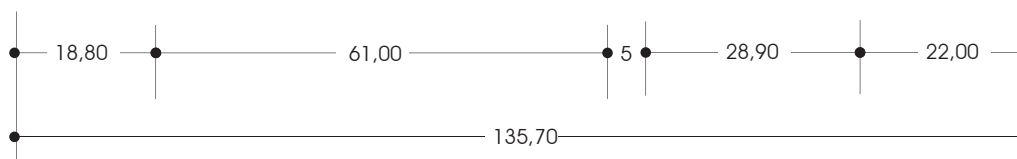
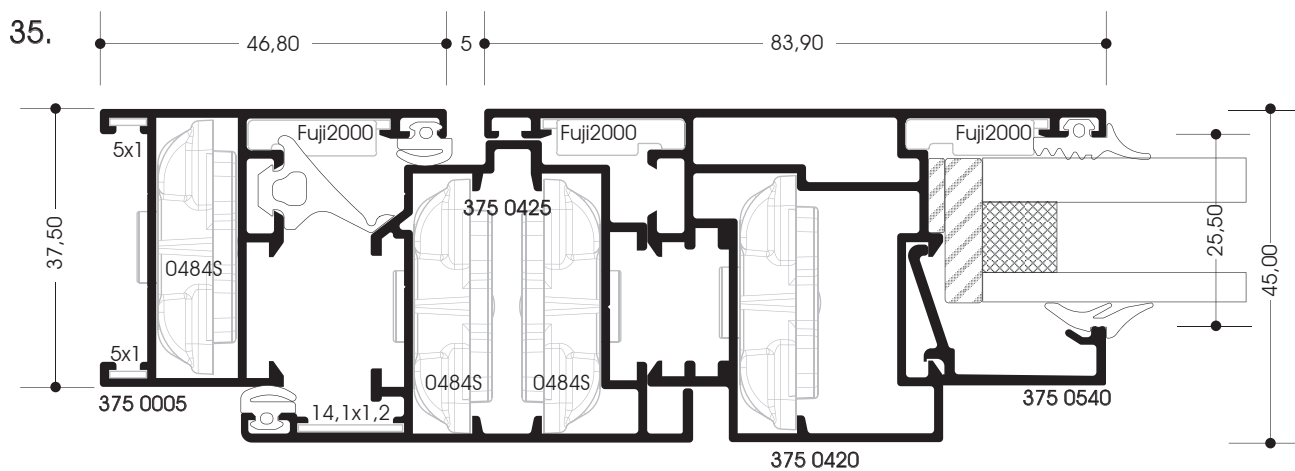

SECTIONS

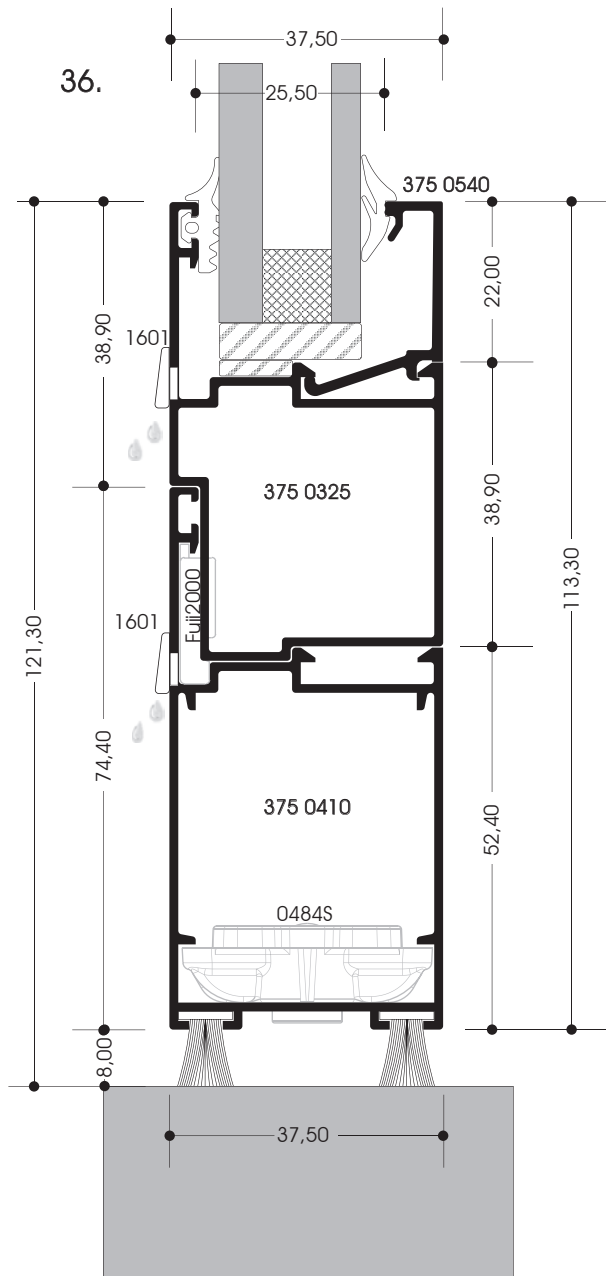
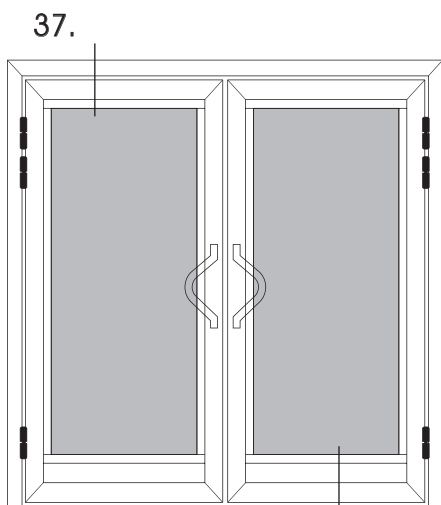
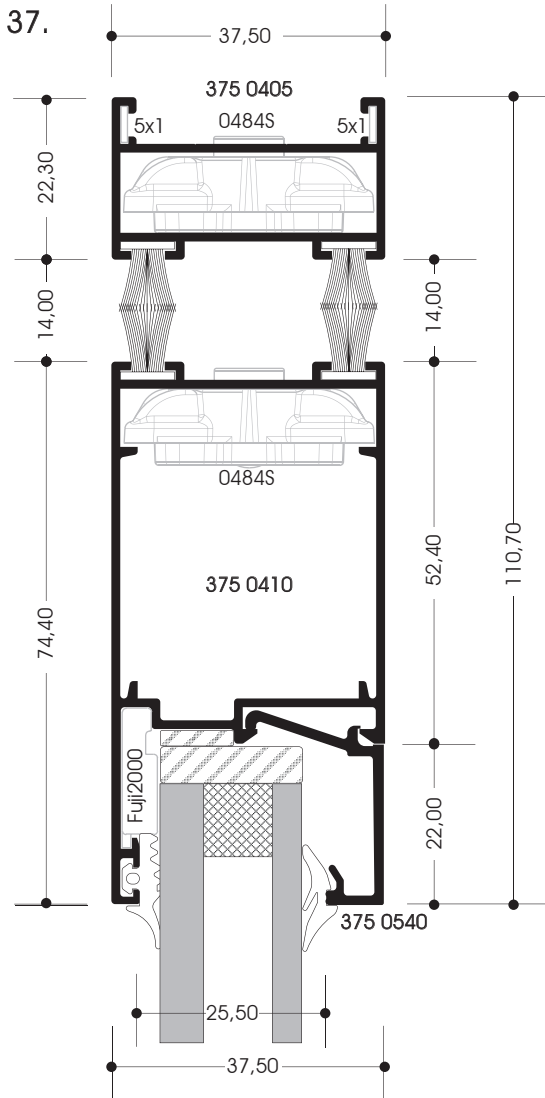

36.

SECTIONS

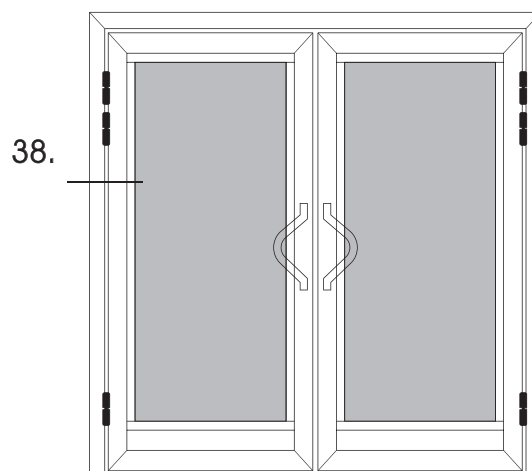
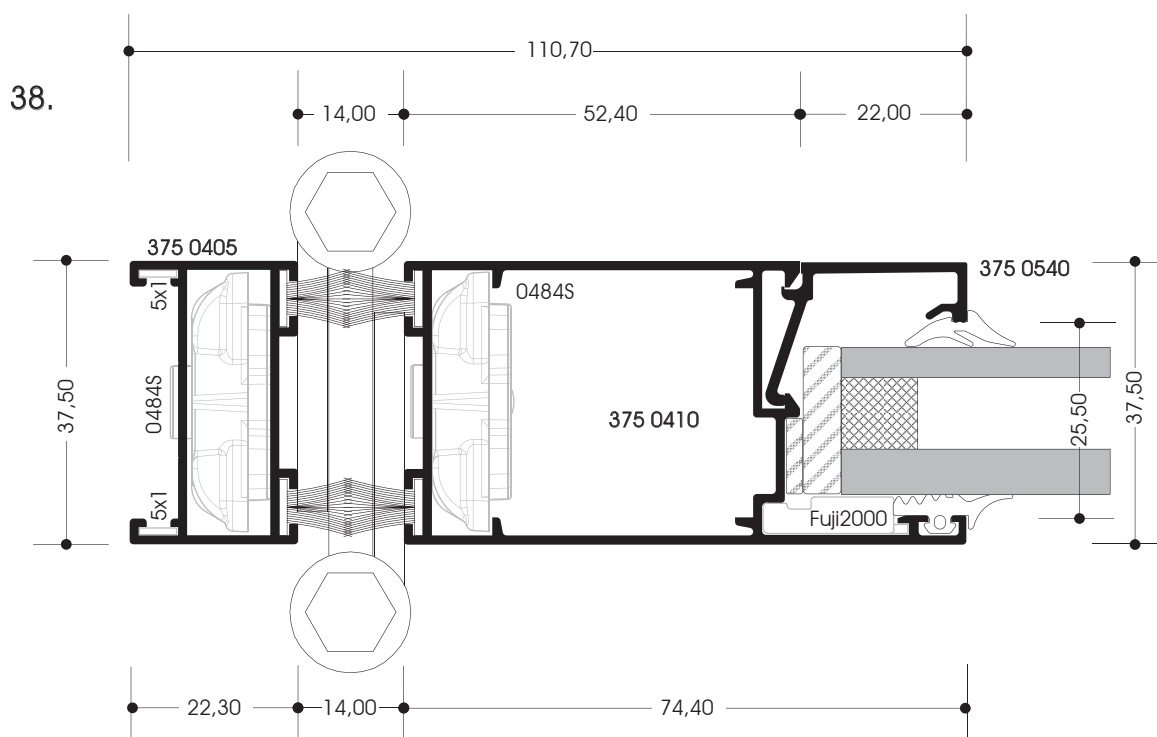

SECTIONS

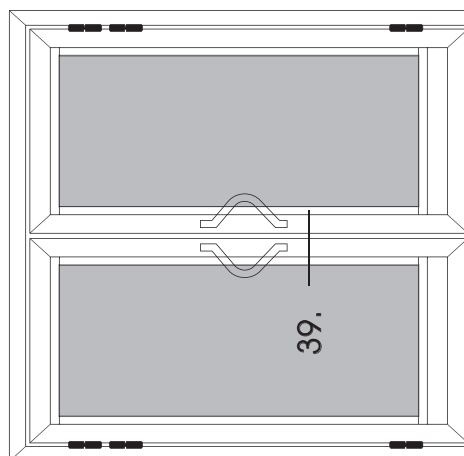
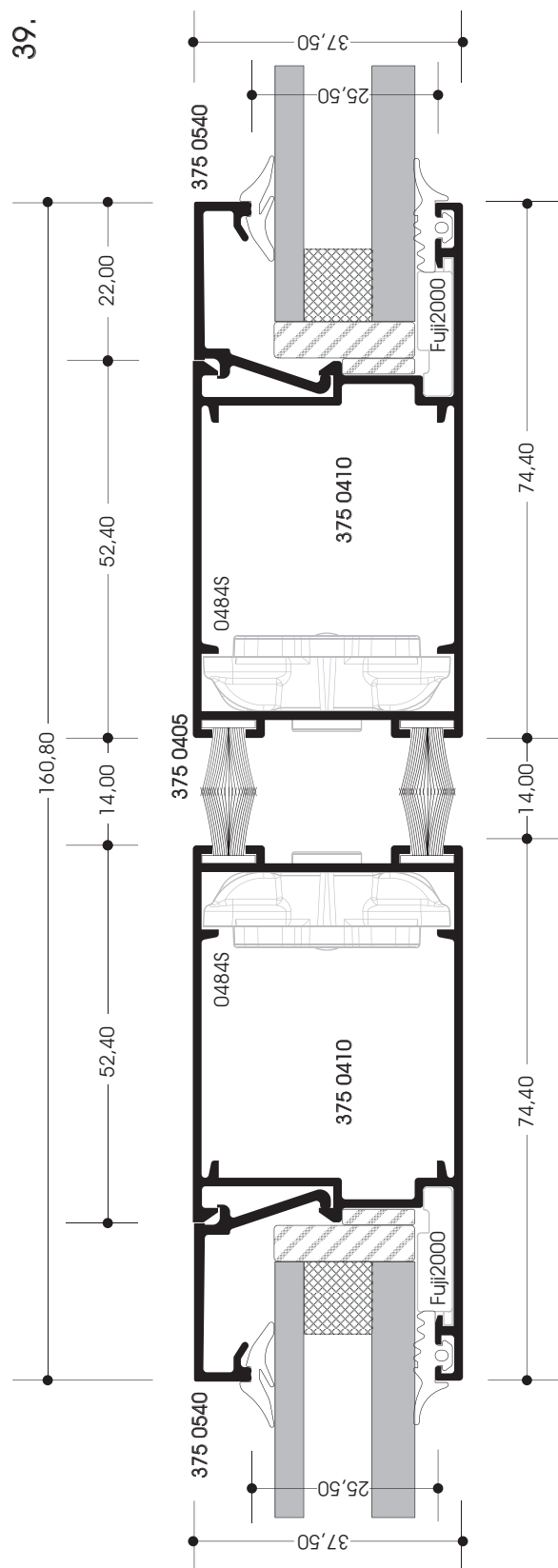

SECTIONS

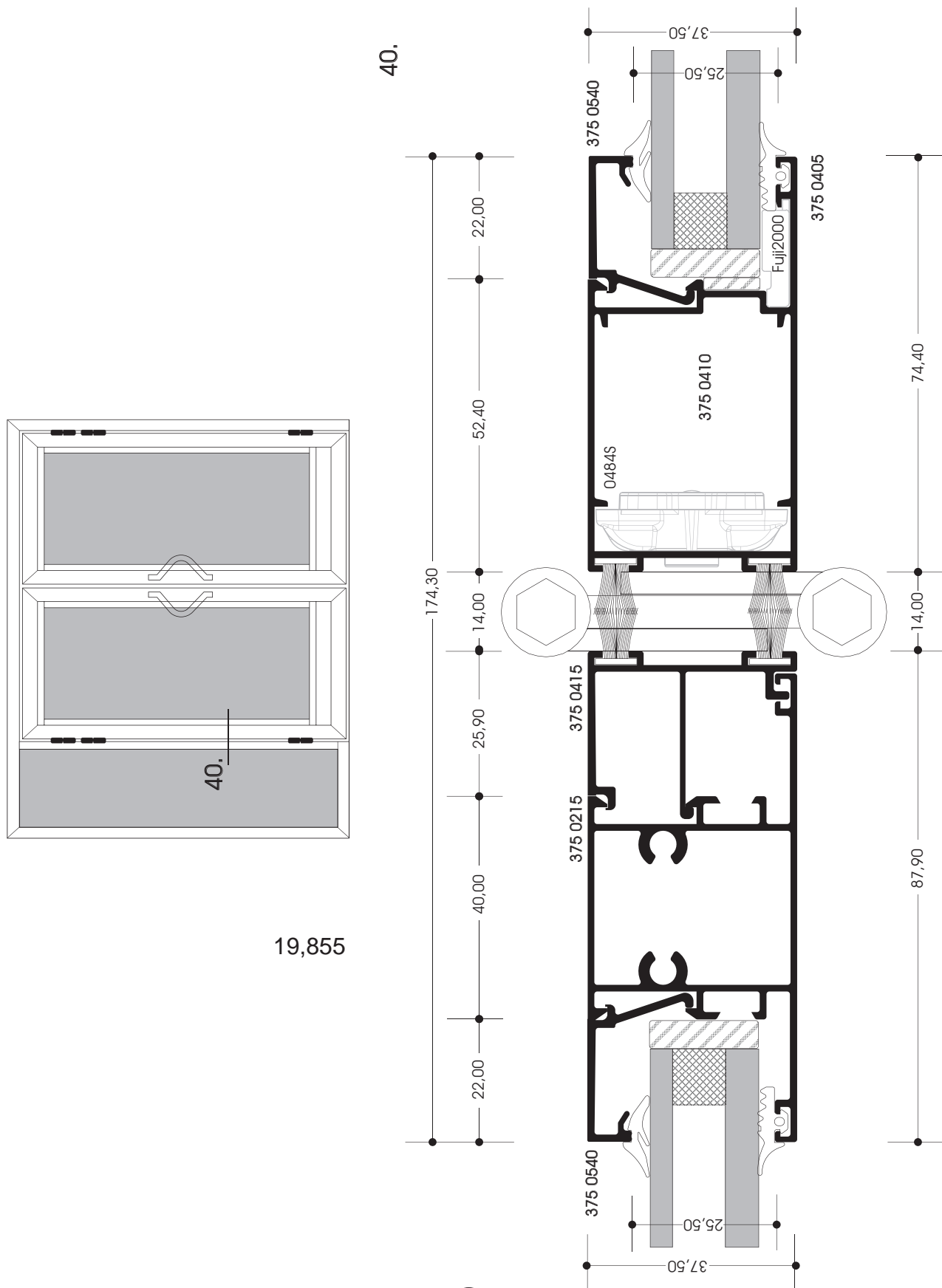

SCHEME

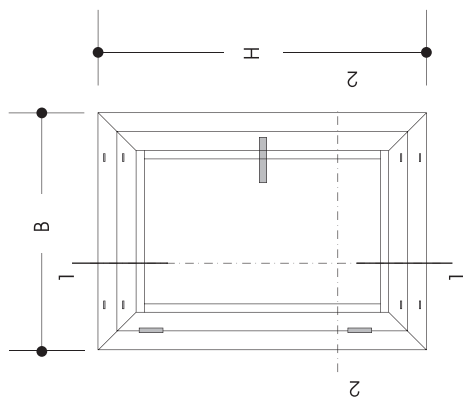

PROFILES	
FRAME	2 pcs = B 2 pcs = H
SASH	2 pcs = B-37,60 mm 2 pcs = H-37,60 mm
For frames : 375 0005, 375 0015, 375 0020, 375 0040, 375 0050	
GLASSHOLDER	2 pcs = B-118,40 mm 2 pcs = H-162,40 mm
For frames : 375 0005, 375 0015, 375 0020, 375 0040, 375 0050 Sash : 375 0105, 375 0125	

CONGEST GASKET	
OUTER	2 pcs = B 2 pcs = H
INNER	2 pcs = B 2 pcs = H
CENTRAL	2 pcs = B 2 pcs = H
GLASS OUTER	2 pcs = B-118mm 2 pcs = H-162mm
GLASS INNER	2 pcs = B-118mm 2 pcs = H-162mm

ACCESSORIES	
MECHANICAL PUTTING	0484 8 pcs
ALIGNMENT ANGLE	14,1x1,2 4 pcs 5x1 8 pcs Fujij2000 8 pcs
DRAINAGE CAP	1601 8 pcs
TWO-WAY MECHANISM	1 set
OR HINGE HANDLE	2 pcs 1 pcs
OR LATCH SCISSORS	2 pcs 1 pcs

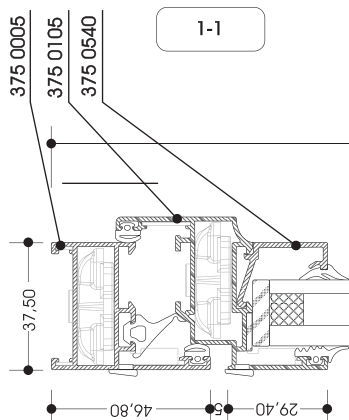

2-2

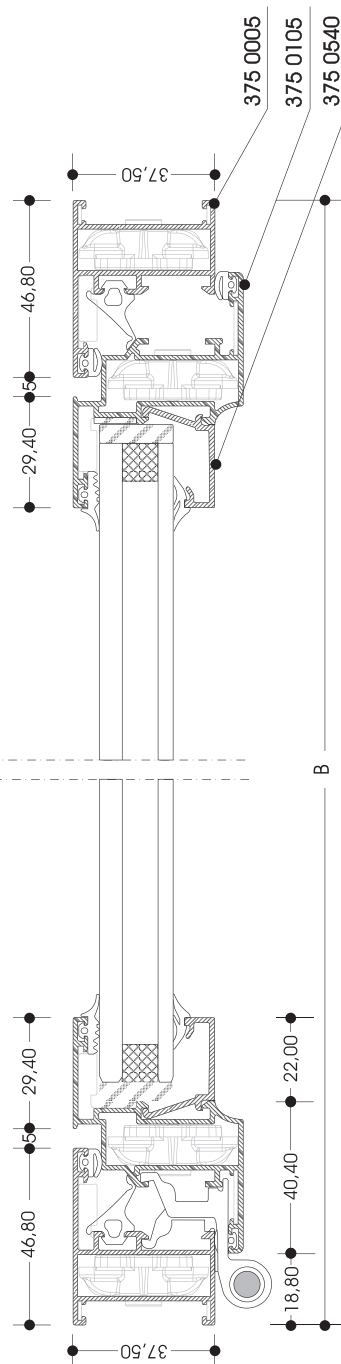

SCHEME

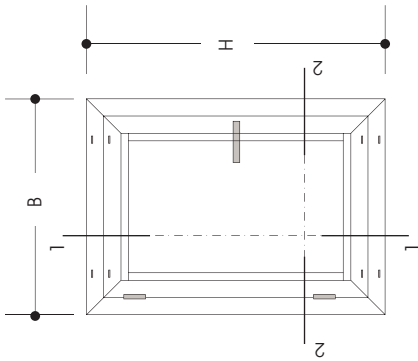

PROFILES	
FRAME	2 pcs = B 2 pcs = H
SASH	2 pcs = B-58,40 mm 2 pcs = H-58,40 mm
For frames : 375 0010, 375 0025, 375 0030, 375 0035, 375 0045 375 0055	
GLASSHOLDER	2 pcs = B-160,20 mm 2 pcs = H-204,20 mm
For frames : 375 0010, 375 0025, 375 0030, 375 0035, 375 0045 Sash : 375 0110, 375 0130	

CONGEST GASKET	
OUTER	2 pcs = B 2 pcs = H
INNER	2 pcs = B 2 pcs = H
CENTRAL	2 pcs = B 2 pcs = H
GLASS OUTER	2 pcs = B-160mm 2 pcs = H-204mm
GLASS INNER	2 pcs = B-160mm 2 pcs = H-204mm

ACCESSORIES	
MECHANICAL PUTTING	0484 8 pcs
ALIGNMENT ANGLE	14,1x1,2 5x1 Fuji2000 8 pcs
DRAINAGE CAP	1601 8 pcs
TWO-WAY MECHANISM	1 set
OR HINGE	2 pcs
HANDLE	1 pcs
OR SCISSORS	2 pcs
LATCH	1 pcs

2-2

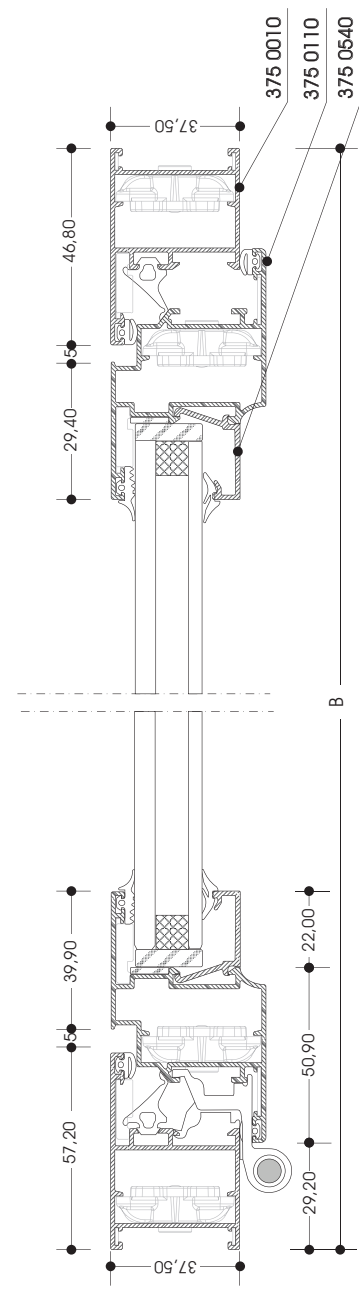

1-1

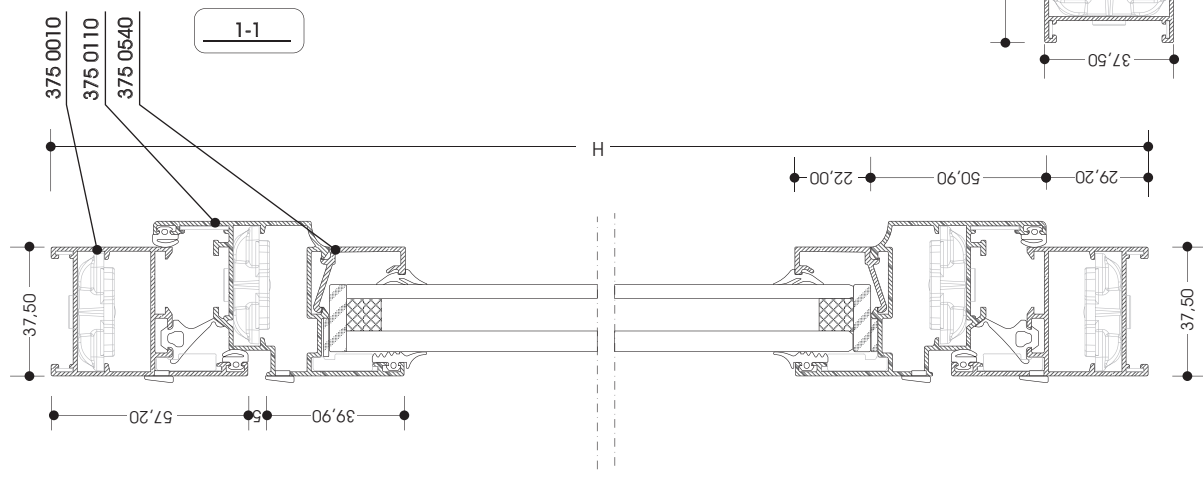

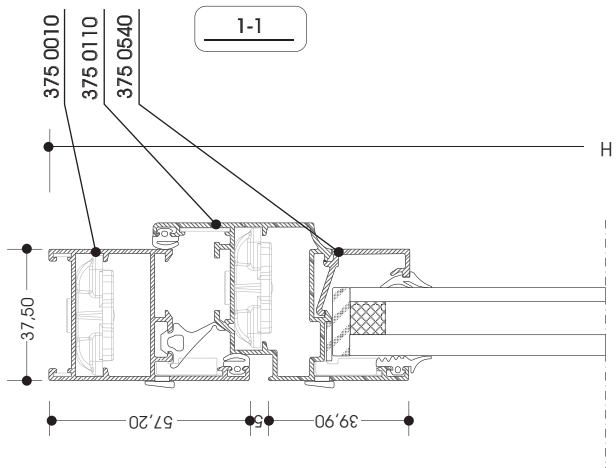
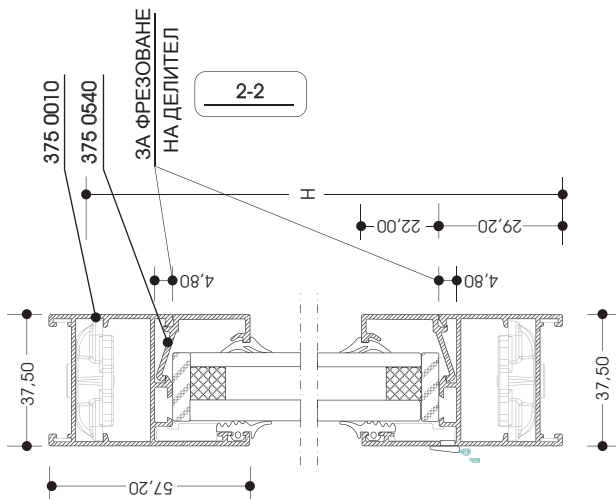
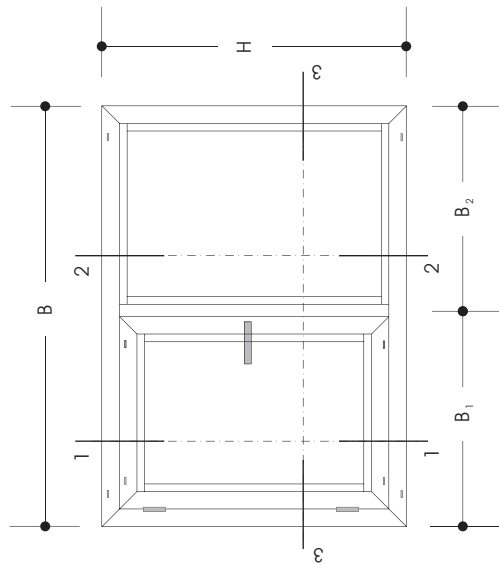

SCHEME



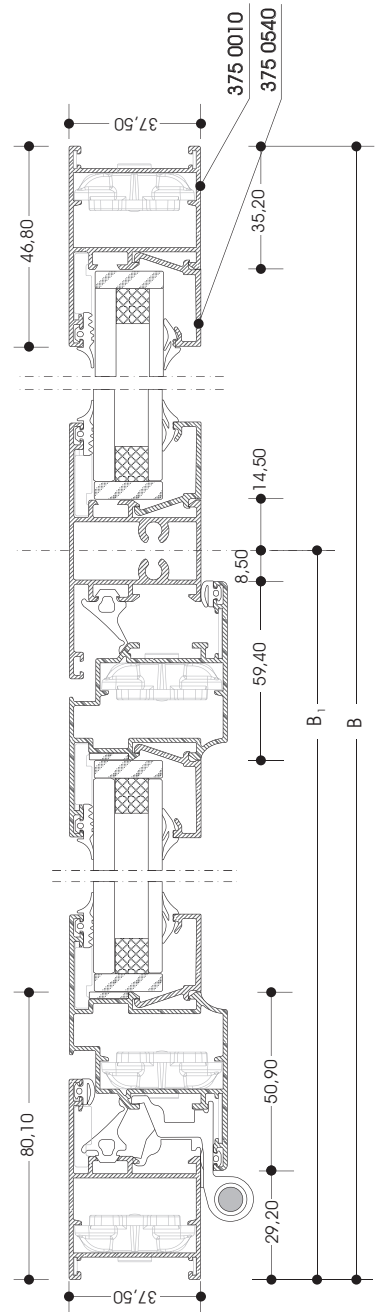

3-3

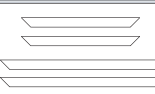
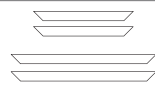
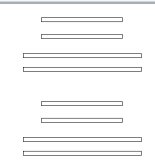

SCHEME

PROFILES			
FRAME	2pcs=B 2pcs=H		
SASH	2pcs=B-37,70 mm* 2pcs=H-58,40 mm	*Only for 375 0210	
For frames : 375 0010,375 0025,375 0030,375 0035,375 0045 375 0055			
GLASSHOLDER	2pcs=B ₁ -139,50 mm* 2pcs=H-204,20 mm 2pcs=B ₂ -49,70 mm* 2pcs=H-114,40 mm		
For frames : 375 0010,375 0025,375 0030,375 0035,375 0045 Sash : 375 0110,375 0130 375 0055			
MULLION	1pcs=H-60,80mm		

ACCESSORIES		
MECHANICAL PUTTING	0484	8pcs
ALIGNMENT ANGLE	14,1x1,2	4pcs
	5x1	8pcs
	Fuji2000	8pcs
DREINAGE CAP	1601	8pcs
TWO-WAY MECHANISM		1 set
OR HINGE HANDLE		2pcs
		1pcs
OR SCISSORS LATCH		2pcs
		1pcs



CONGEST GASKETS	
OUTER	2pcs=B 2pcs=H
INNER	2pcs=B 2pcs=H
CENTRAL	2pcs=B ₁ 2pcs=H
GLASS OUTER	2pcs=B ₁ -139mm* 2pcs=H-204mm 2pcs=B ₂ -49mm* 2pcs=H-114mm
GLASS INNER	2pcs=B ₁ -139mm* 2pcs=H-204mm 2pcs=B ₂ -49mm* 2pcs=H-114mm

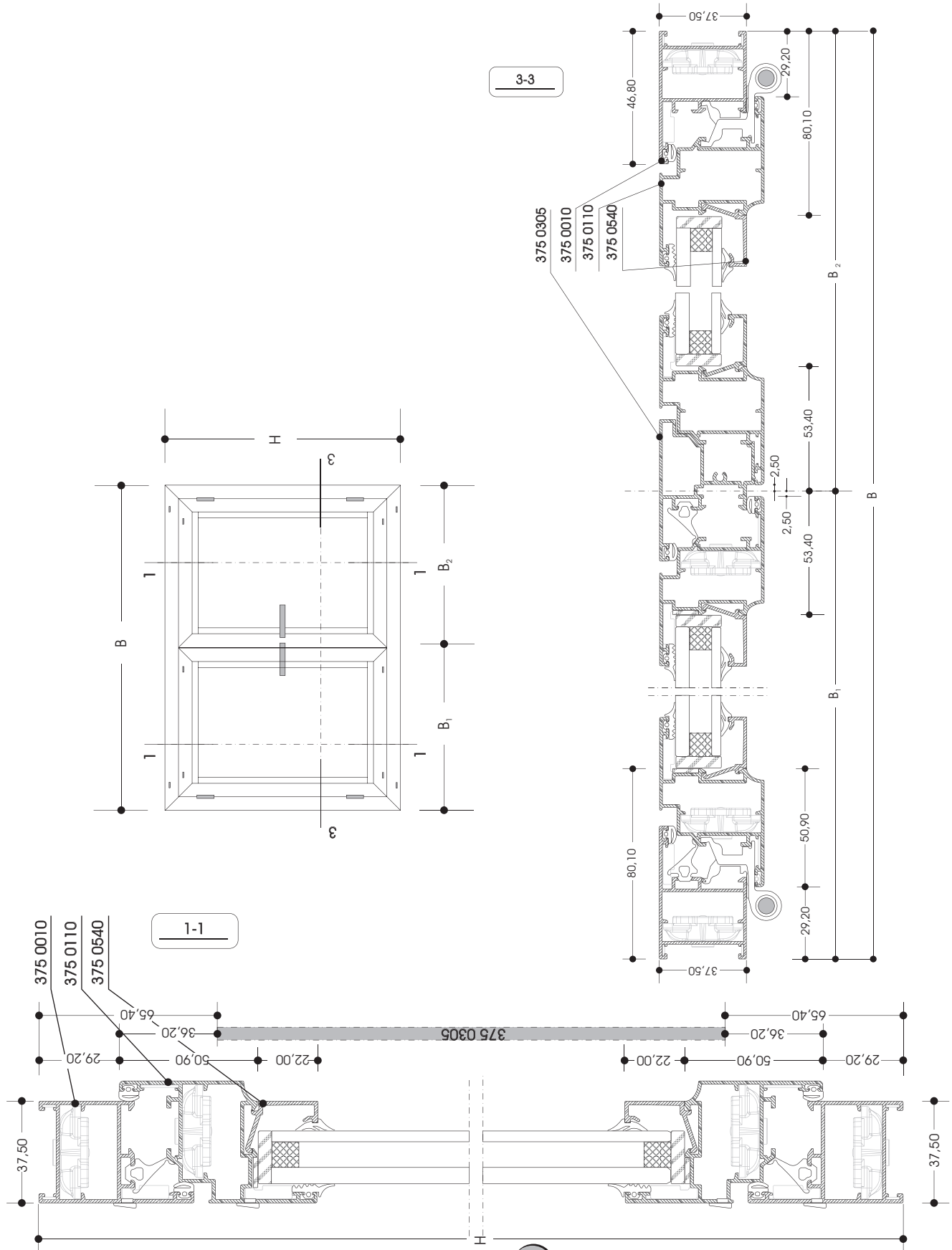

*Only for 375 0210

SCHEME

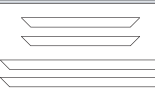
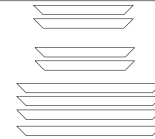
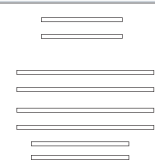





SCHEME

PROFILES			
FRAME	2pcs=B 2pcs=H		
SASH	2pcs=B ₁ -31,70 mm 2pcs=B ₂ -31,70 mm 4pcs=H-58,40 mm		
For frames : 375 0010, 375 0025, 375 0030, 375 0035, 375 0045 375 0055			
GLASSHOLDER	2pcs=B ₁ -133,50 mm* 4pcs=H-204,20 mm 2pcs=B ₂ -133,50 mm*		
For frames : 375 0010, 375 0025, 375 0030, 375 0035, 375 0045 Sash : 375 0110, 375 0130 375 0055			
ADDITION FOR TWO-WING	1pcs=H-130,80mm		
For frames : 375 0010, 375 0025, 375 0030, 375 0035, 375 0045 375 0055			

ACCESSORIES		
MECHANICAL PUTTING	0484	12pcs
ALIGNMENT ANGLE	14,1x1,2	8pcs
	5x1	8pcs
	Fuji2000	12pcs
DREINAGE CAP	1601	12pcs
TWO-WAY MECHANISM		1set
HINGE HANDLE		2pcs
		1pcs
LATCH FOR TWO-WING		1set
CAP FOR TWO-WING		2pcs
OR HINGE HANDLE		4pcs
		2pcs
LATCH FOR TWO-WING		1set

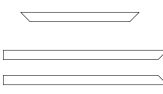
CONGEST CASKETS	
OUTER	2pcs=B 2pcs=H
INNER	2pcs=B 2pcs=H
CENTRAL	2pcs=B ₁ 2pcs=H 1pcs=H-131mm
GLASS OUTER	2pcs=B ₁ -133mm 4pcs=H-204mm 2pcs=B ₂ -133mm
GLASS INNER	2pcs=B ₁ -133mm 4pcs=H-204mm 2pcs=B ₂ -133mm

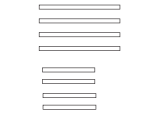
SCHEME

PROFILES			
FRAME	1pcs=B 2pcs=H		
SASH	1pcs=B-58,40 mm 2pcs=H-37,20 mm		
For frames : 375 0010,375 0025,375 0030,375 0035,375 0045 375 0055			
GLASSHOLDER	4pcs=B-202,20 2pcs=H ₁ -174,50 mm* 2pcs=H ₂ -159,80 mm		
For frames :375 0010,375 0025,375 0030,375 0035,375 0045 Sash : 375 0115,375 0120,375 0150,375 0140 375 0055			
MULLION	1pcs=B-192,60mm		
For frames :375 0010,375 0025,375 0030,375 0035,375 0045 Sash : 375 0115,375 0120,375 0150,375 0140 375 0055			
BOARD FOR DOOR	1pcs=B-192,60mm		
For frames :375 0010,375 0025,375 0030,375 0035,375 0045 Sash : 375 0115,375 0120,375 0150,375 0140 375 0055			

ACCESSORIES		
MECHANICAL PUTTING	0484	4pcs
ALIGNMENT ANGLE	14,1x1,2	2pcs
	5x1	4pcs
	Fuji2000	4pcs
DREINAGE CAP	1601	4pcs
CONGEST SYSTEM		1pcs
HINGE HANDLE		3pcs 1set
LOCK 35mm PATRON OPPOSITER		1set

CONGEST GASKETS	
OUTER	2pcs=B 2pcs=H
INNER	2pcs=B 2pcs=H
CENTRAL	2pcs=B 2pcs=H
GLASS OUTER	4pcs=B-202mm 2pcs=H ₁ -174mm* 2pcs=H ₂ -159mm*
GLASS INNER	4pcs=B-202mm 2pcs=H ₁ -174mm* 2pcs=H ₂ -159mm*
BRUSH-8mm	1pcs=H ₂ -58mm

*- Only for mullion 375 0210

SCHEME

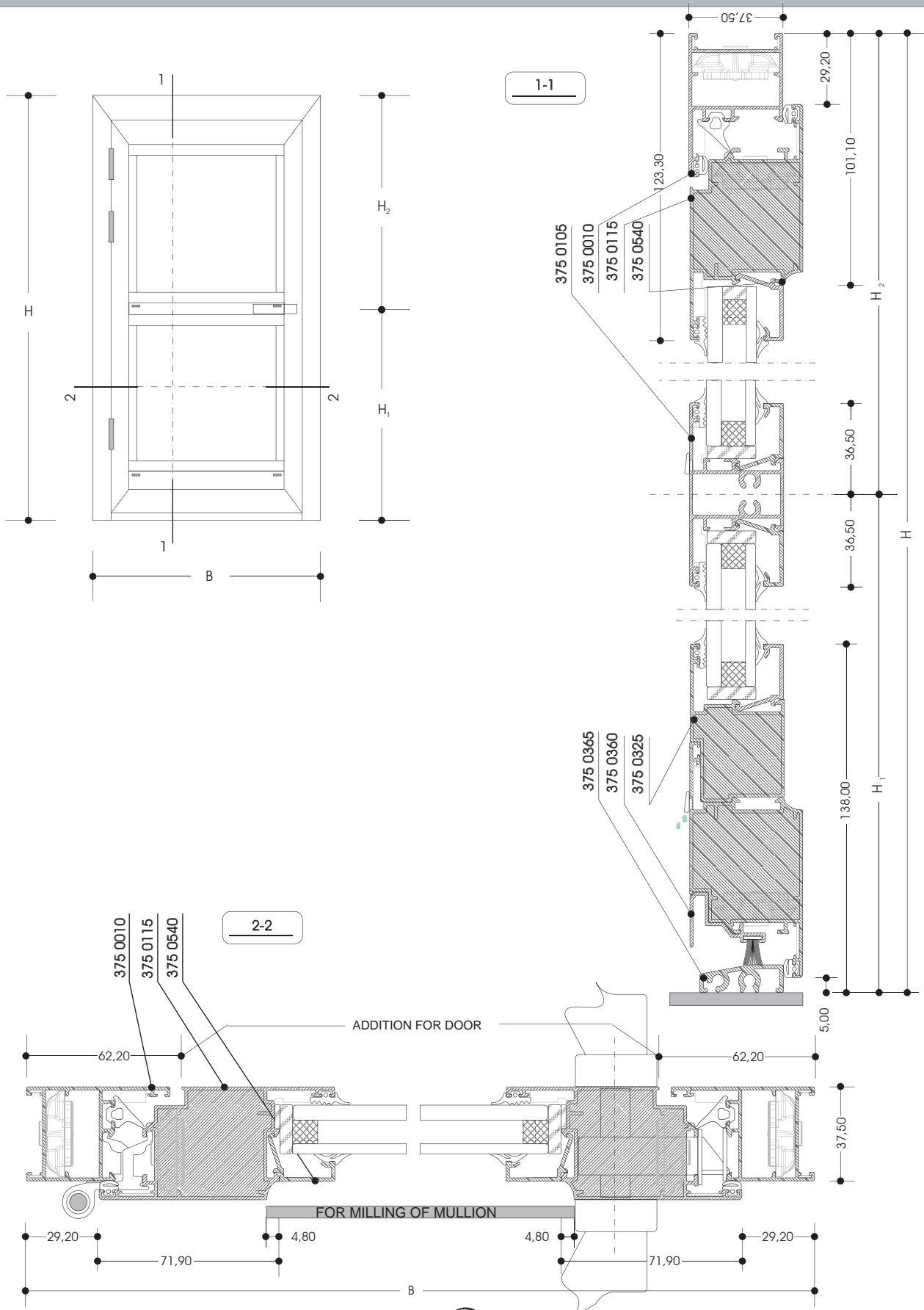

SCHEME

PROFILES			
FRAME	1pcs=B 2pcs=H		
SASH	1pcs=B-58,40 mm 2pcs=H-34,20 mm		
For frames :375 0010,375 0025,375 0030,375 0035,375 0045 375 0055			
GLASSHOLDER	4pcs=B-202,20 2pcs=H ₁ -174,50 mm* 2pcs=H ₂ -159,80 mm	*Само за делител375 0210	
For frames :375 0010,375 0025,375 0030,375 0035,375 0045 Sash :375 0115,375 0120,375 0150,375 0140 375 0055			
MULLION	1pcs=B-192,60mm		
For frames :375 0010,375 0025,375 0030,375 0035,375 0045 Sash :375 0115,375 0120,375 0150,375 0140 375 0055			
ADDITION FOR DOOR	1pcs=B-192,60mm		
For frames :375 0010,375 0025,375 0030,375 0035,375 0045 Sash :375 0115,375 0120,375 0150,375 0140 375 0055			
ADDITION FOR DOOR	1pcs=B-124,40mm	375 0360	
For frames :375 0010,375 0025,375 0030,375 0035,375 0045 Sash :375 0115,375 0120,375 0150,375 0140 375 0055			
DOOR-SILL	1pcs=B-58,40mm**	375 0365	
For frames :375 0010,375 0025,375 0030,375 0035,375 0045 375 0055			

**Without cap

ACCESSORIES		
MECHANICAL PUTTING	0484	6pcs
ALIGNMENT ANGLE	14,1x1,2	4pcs
	5x1	4pcs
	Fuji2000	6pcs
DREINAGE CAP	1601	8pcs
HINGE HANDLE		3pcs
		1set
LOCK35mm PATRON OPPOSITER		1set

CONGEST GASKETS	
OUTER	2pcs=B 2pcs=H
INNER	2pcs=B 2pcs=H
CENTRAL	2pcs=B 2pcs=H
GLASS OUTER	4pcs=B-202mm 2pcs=H ₁ -174mm* 2pcs=H ₂ -159mm*
GLASS INNER	4pcs=B-202mm 2pcs=H ₁ -174mm* 2pcs=H ₂ -159mm*
BRUSH-8mm	1pcs=H ₂ -58mm

*- Only for mullion 375 0210

SCHEME

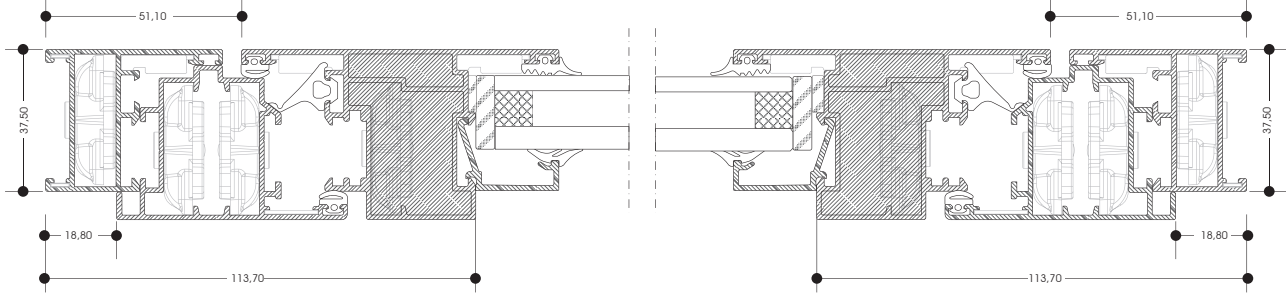

2-2

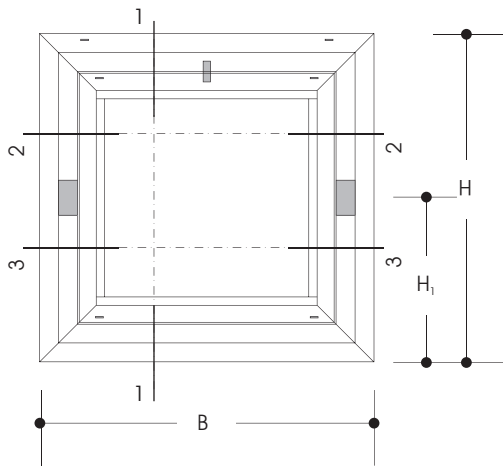

1-1

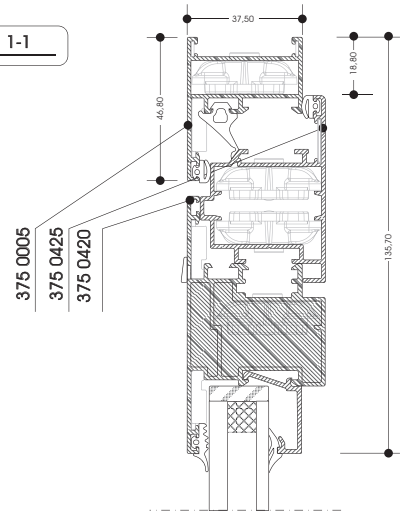

3-3

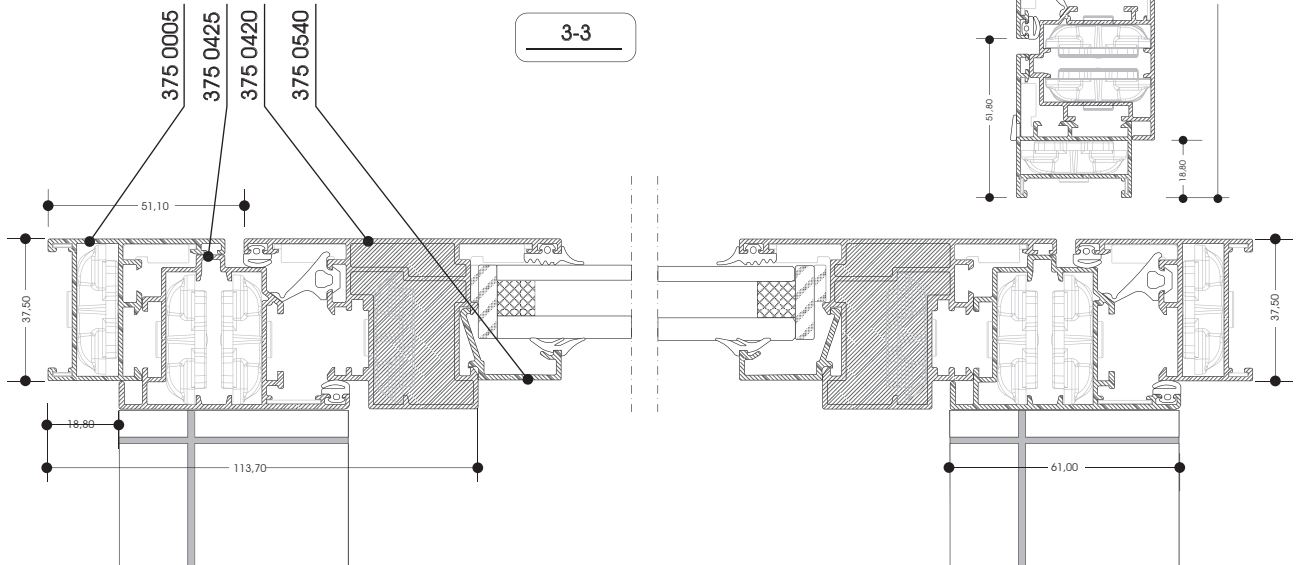

SCHEME

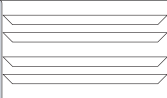
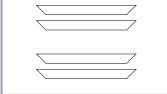
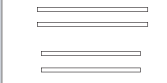
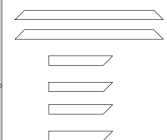
PROFILES			
FRAME	2pcs=B 2pcs=H		
SASH	2pcs=B-103,60 mm 2pcs=H-103,60 mm		
For frames : 375 0005,375 0015,375 0020,375 0040,375 0050			
GLASSHOLDER	2pcs=B-227,40 mm 2pcs=H-271,40 mm		
For frames : 375 0005,375 0015,375 0020,375 0040,375 0050			
ADDITION	2pcs=B-37,60 mm 4pcs=H,-49,30 mm		
For frames : 375 0005,375 0015,375 0020,375 0040,375 0050			

ACCESSORIES		
MECHANICAL PUTTING	0484	12pcs
ALIGNMENT ANGLE	14,1x1,2	4pcs
	5x1	8pcs
	Fuji2000	12pcs
DREINAGE CAP	1601	8pcs
REVOLVING MECHANISM		2pcs
HANDLE OR LATCH		1pcs

CONGEST GASKETS	
OUTER	2pcs=B 2pcs=H
INNER	2pcs=B 2pcs=H
CENTRAL	2pcs=B 2pcs=H
GLASS OUTER	2pcs=B-118mm 2pcs=H-162mm
GLASS INNER	2pcs=B-118mm 2pcs=H-162mm

SCHEME

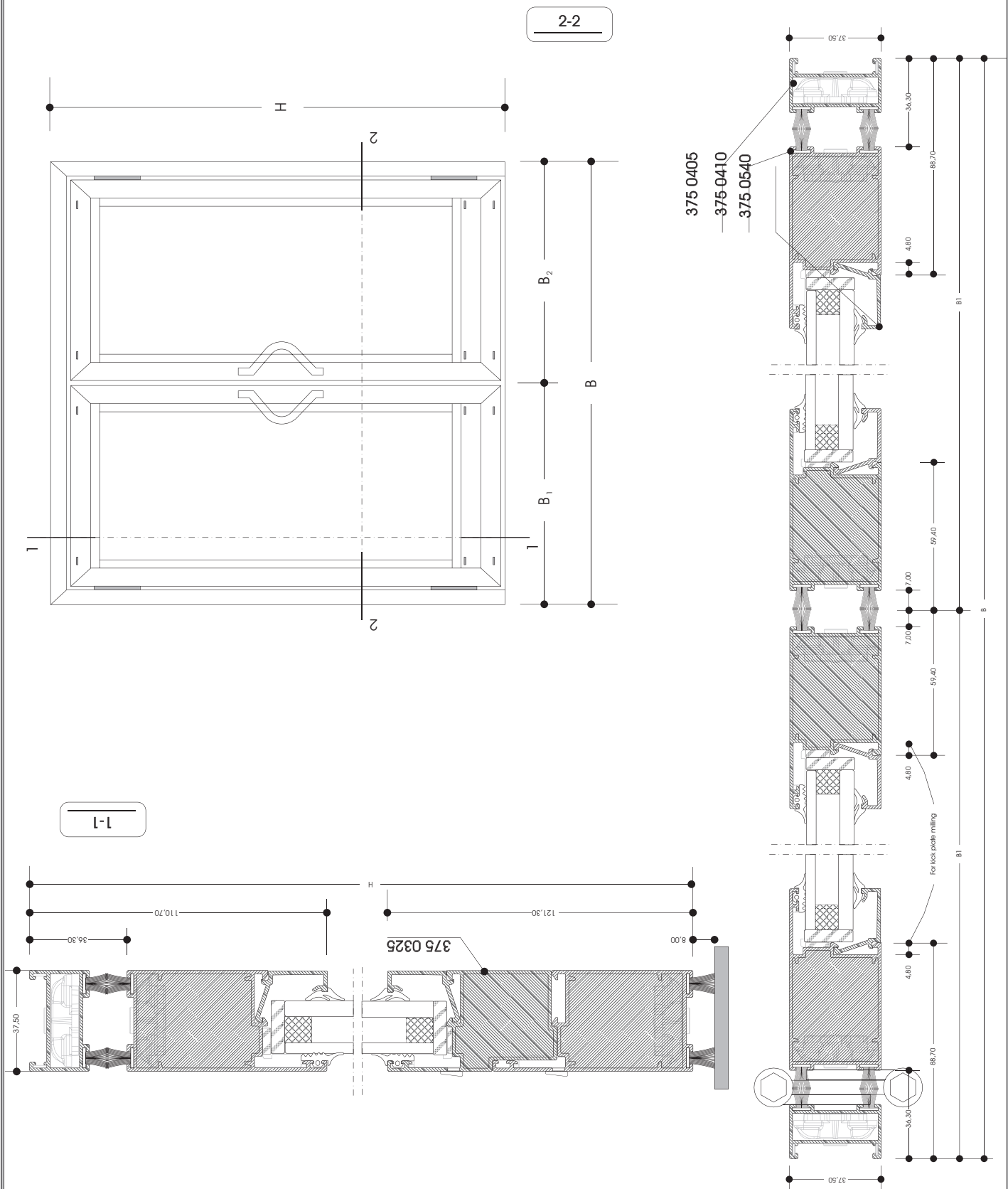

SCHEME

PROFILES			
FRAME	1pcs=B 2pcs=H		
SASH	2pcs=B ₁ -43,30 mm 2pcs=B ₂ -43,30 mm 4pcs=H-44,30 mm		
ADDITION	1pcs=B ₁ -138,50 mm 1pcs=B ₂ -138,50 mm		
GLASSHOLDER	2pcs=B ₁ -148,10 mm 2pcs=B ₂ -148,10 mm 4pcs=H-232,00 mm		

ACCESSORIES		
MECHANICAL PUTTING	0484	10pcs
ALIGNMENT ANGLE	5x1	4pcs
	Fuji2000	8pcs
DREINAGE CAP	1601	12pcs
HINGES FOR TWO-SIDE		4pcs
HANDLES FOR DOOR		4pcs

CONGEST GASKETS	
OUTER	2pcs=B ₁ -148 2pcs=B ₂ -148 4pcs=H - 232
INNER	2pcs=B ₁ -148 2pcs=B ₂ -148 4pcs=H - 232
BRUSH	4pcs=B 8pcs=H

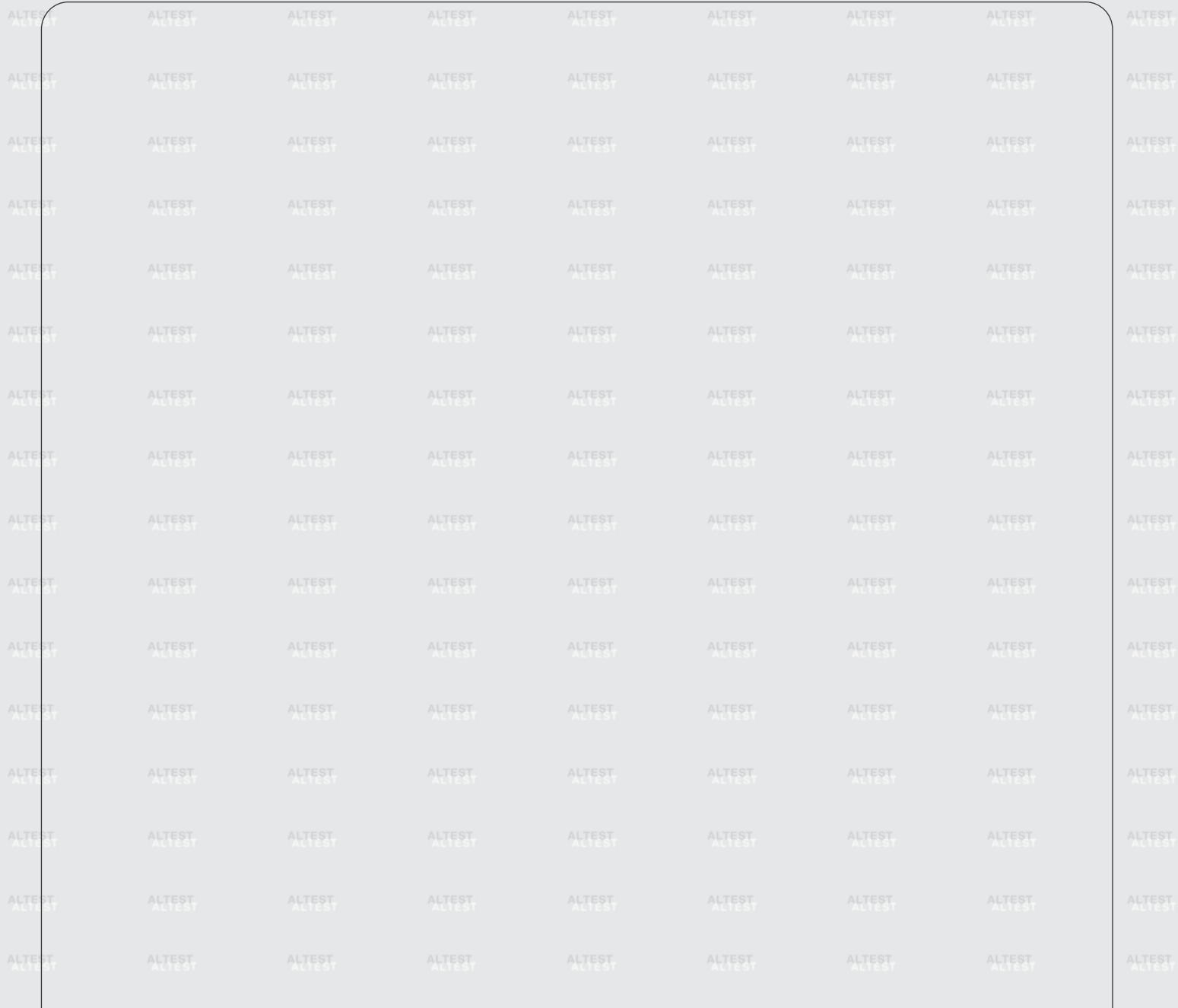

Three dimension details



3D DETAILS

MECHANICAL PUTTING AND ALIGNMENT ANGLES FOR LITTLE FRAME

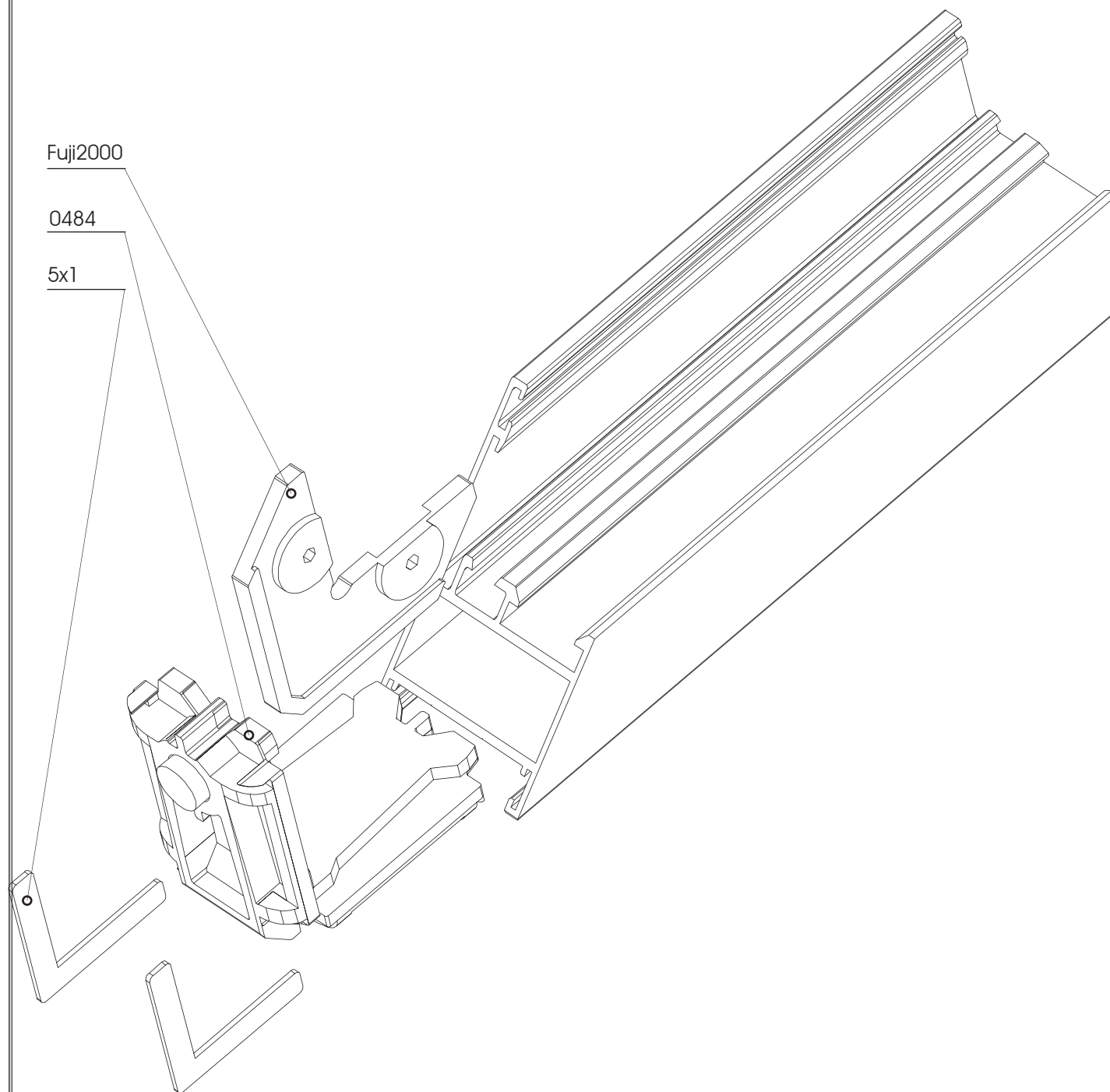

3D DETAILS

PRESS PUTTING AND ALIGNMENT ANGLES FOR LITTLE FRAME

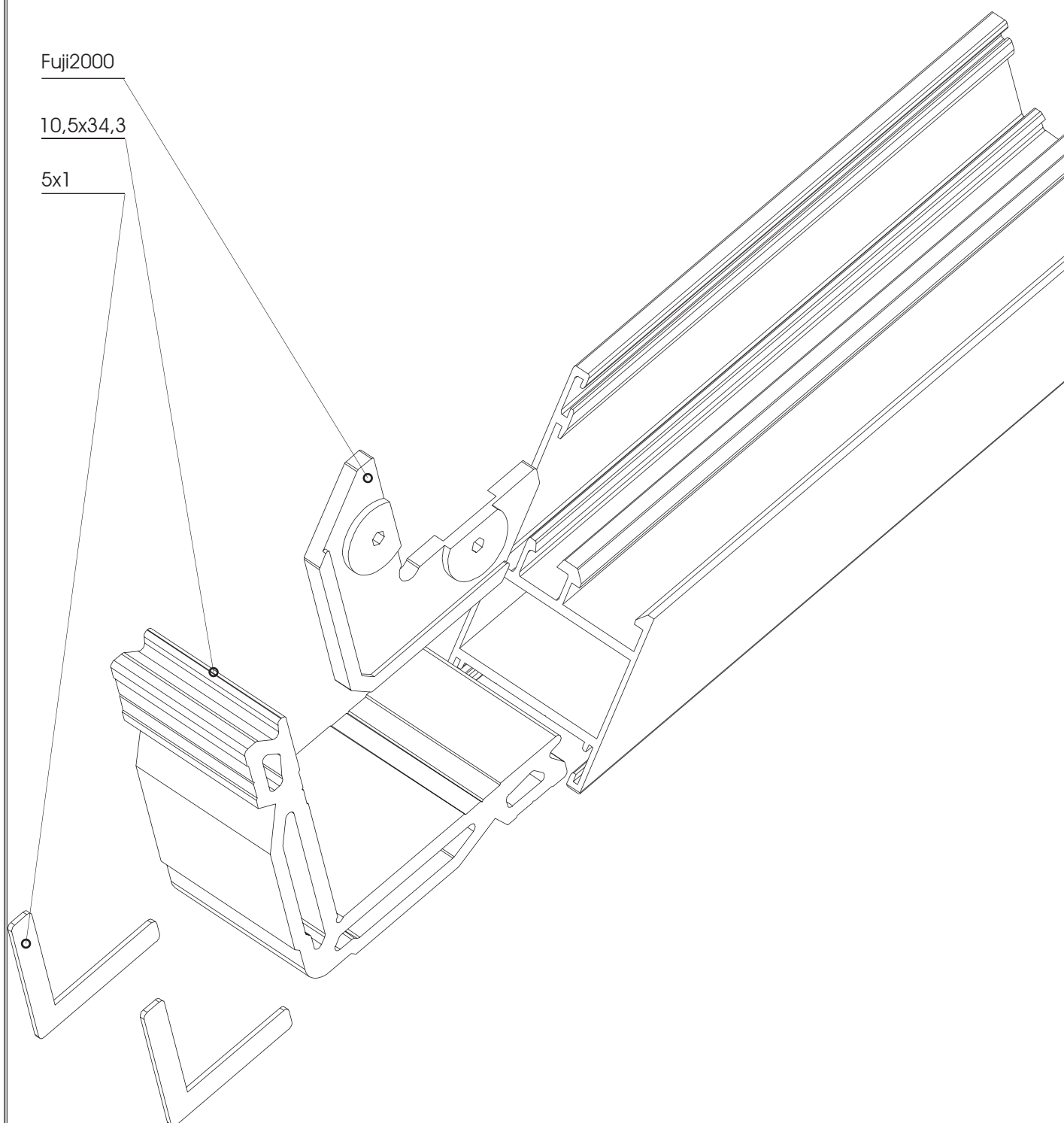

3D DETAILS

MECHANICAL PUTTING + ADDITION AND ALIGNMENT ANGLES FOR BIG FRAME

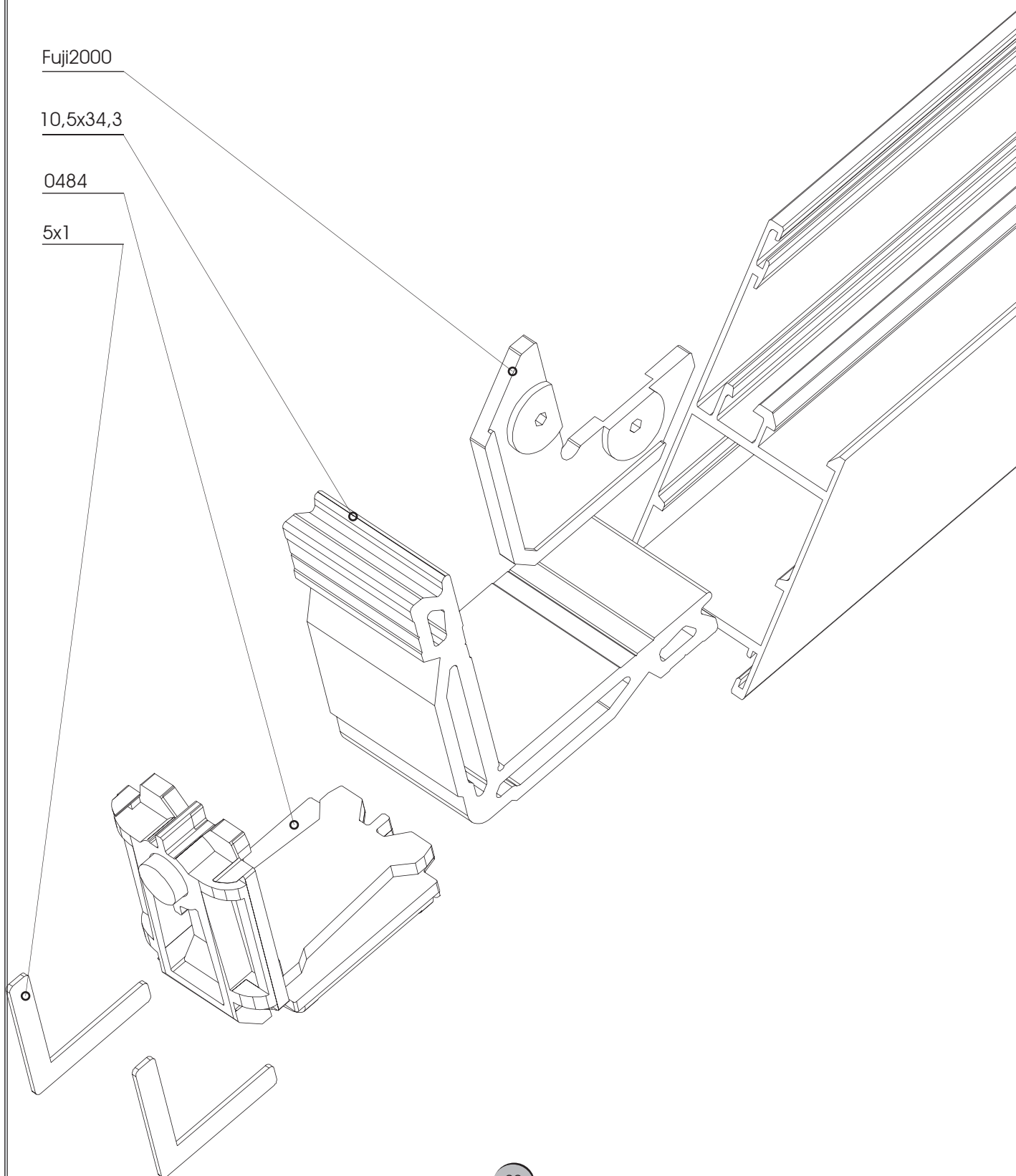

3D DETAILS

PRESS PUTTING AND ALIGNMENT ANGLES FOR BIG FRAME

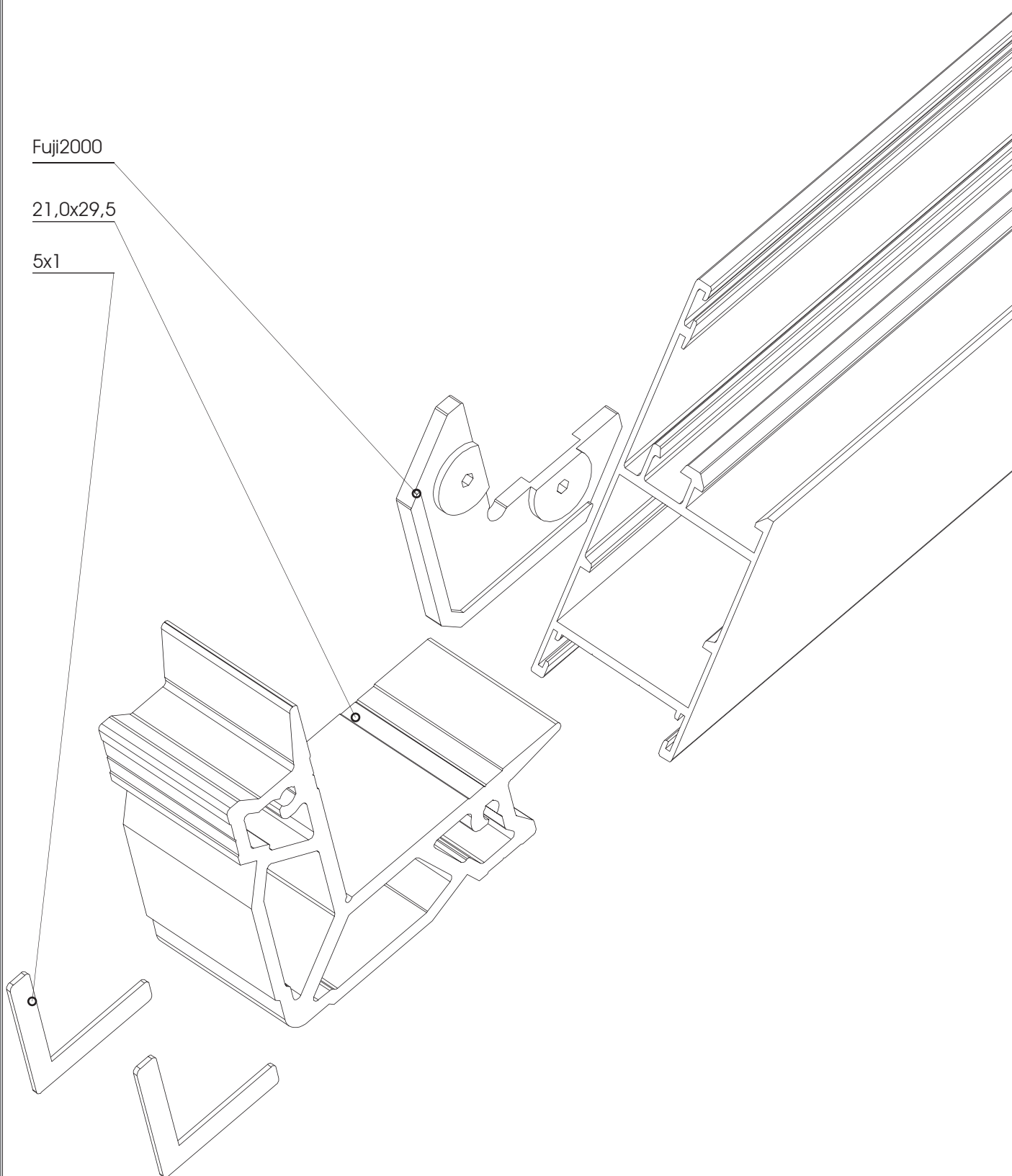

3D DETAILS

MECHANICAL PUTTING AND ALIGNMENT ANGLES FOR LITTLE SASH

Fuji2000

0484

14,1x1,2

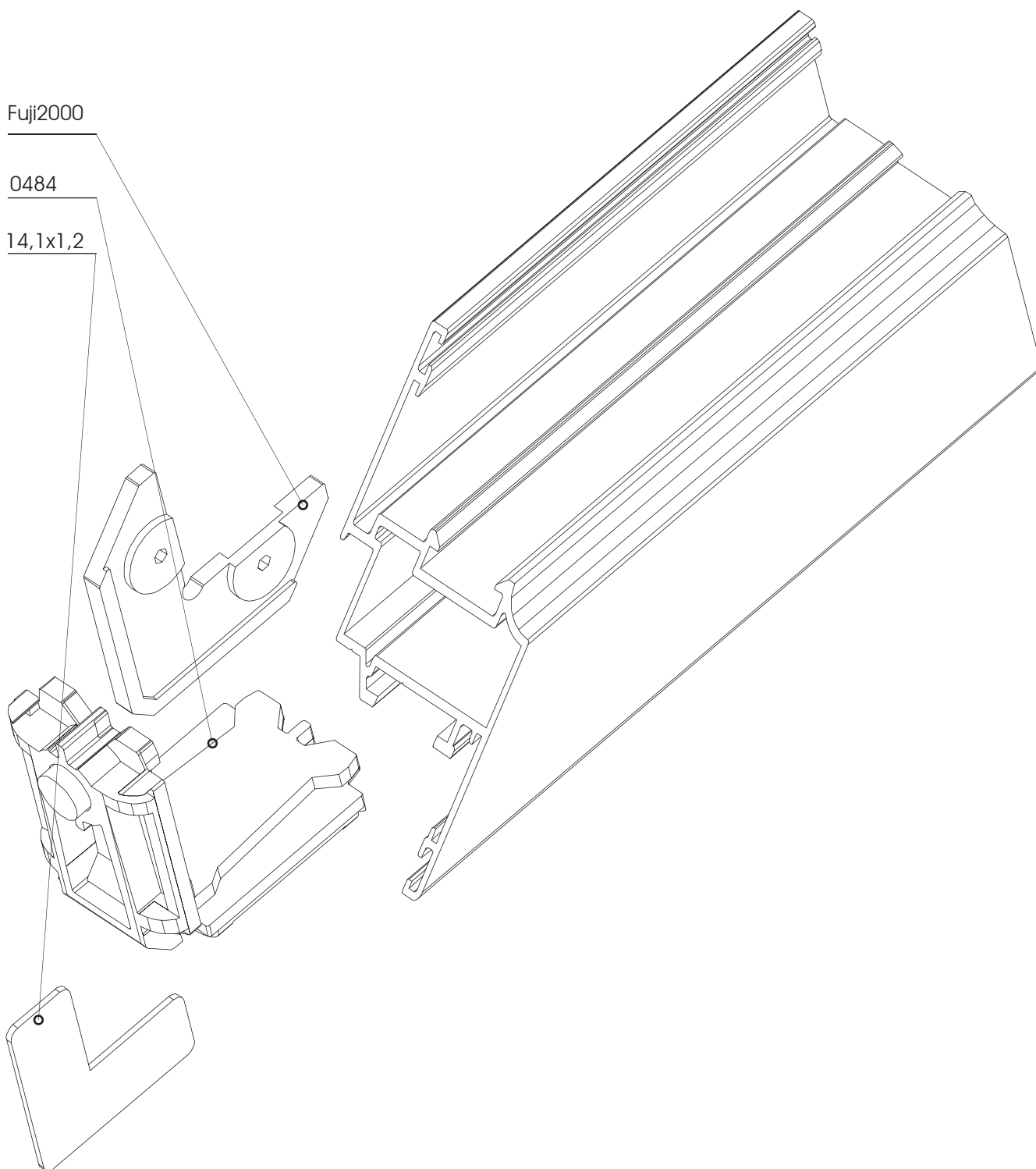

3D DETAILS

PRESS PUTTING AND ALIGNMENT ANGLES FOR LITTLE SASH

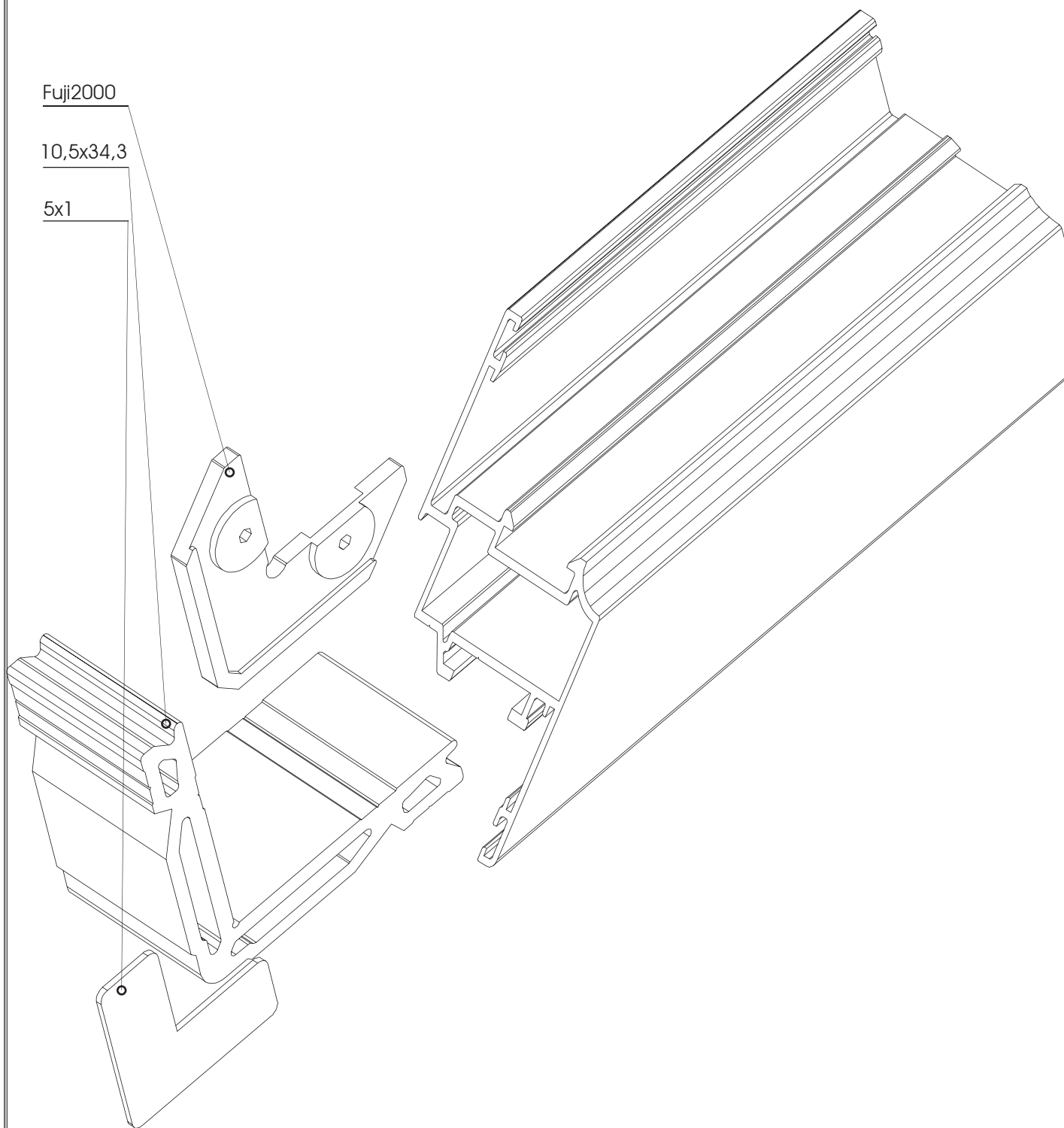

3D DETAILS

MECHANICAL PUTTING + ADDITION AND ALIGNMENT ANGLES FOR MIDDLE SASH

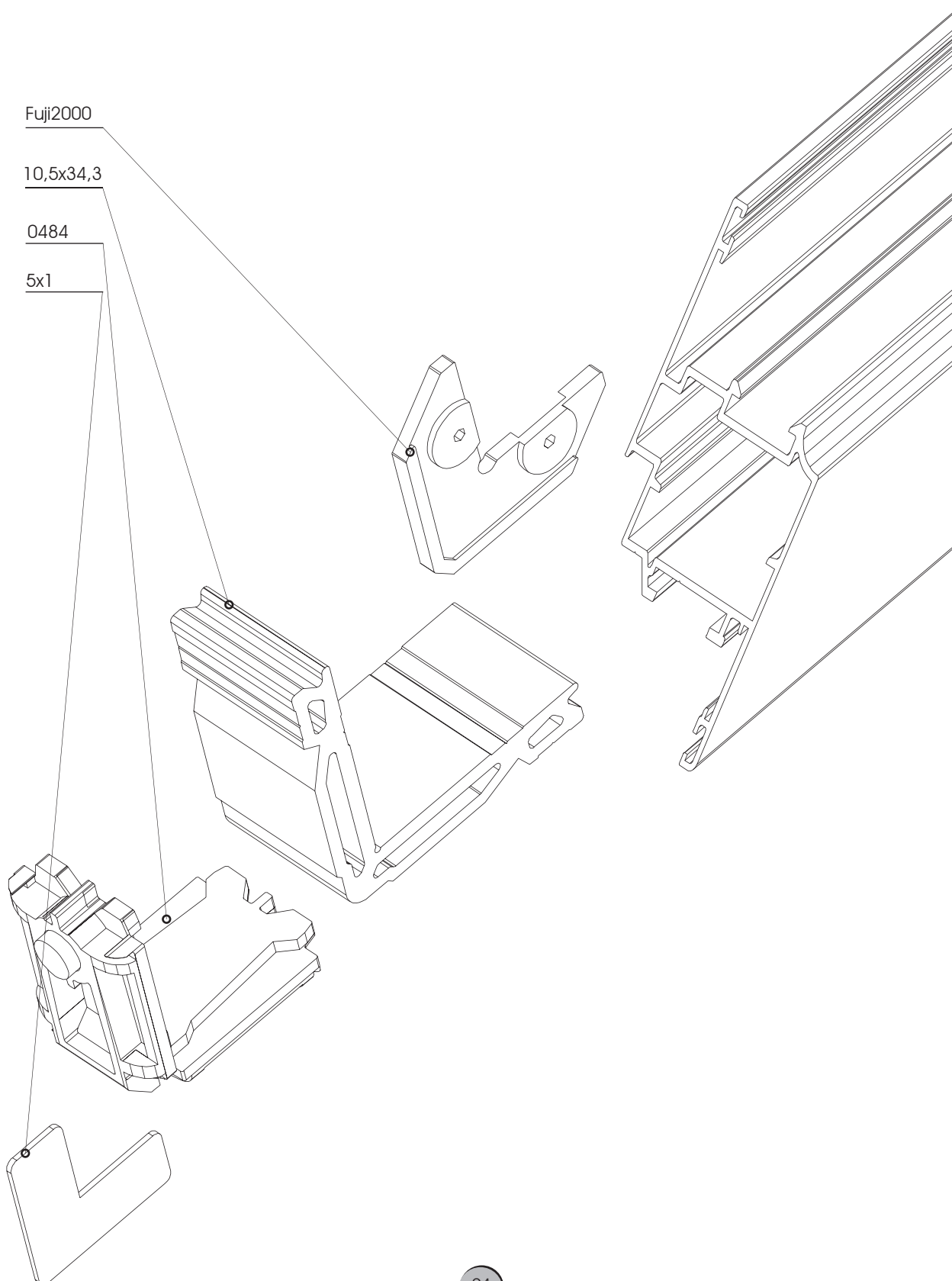

3D DETAILS

PRESS PUTTING AND ALIGNMENT ANGLES FOR MIDDLE SASH

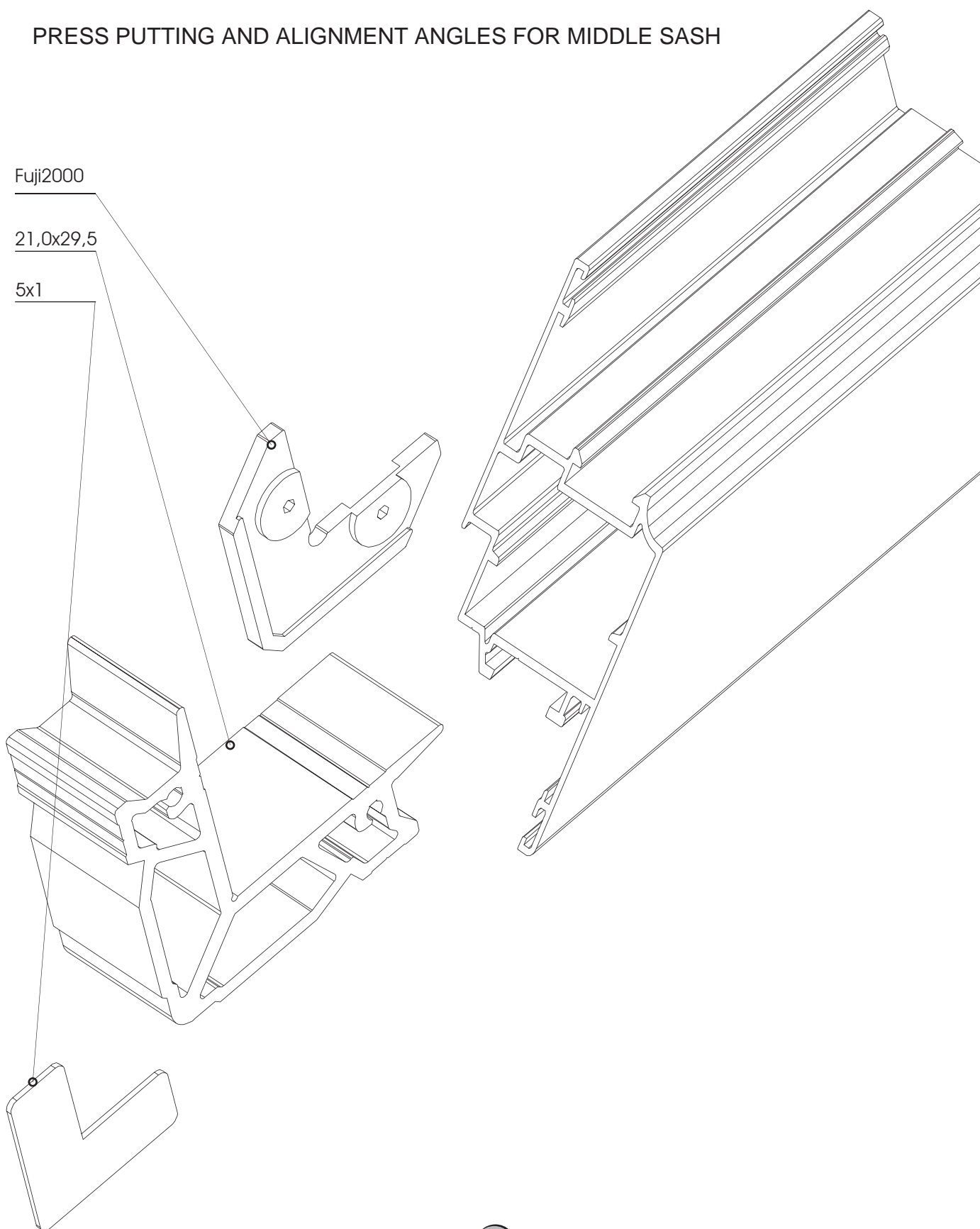

3D DETAILS

MECHANICAL PUTTING + ADDITION AND ALIGNMENT ANGLES FOR BIG SASH

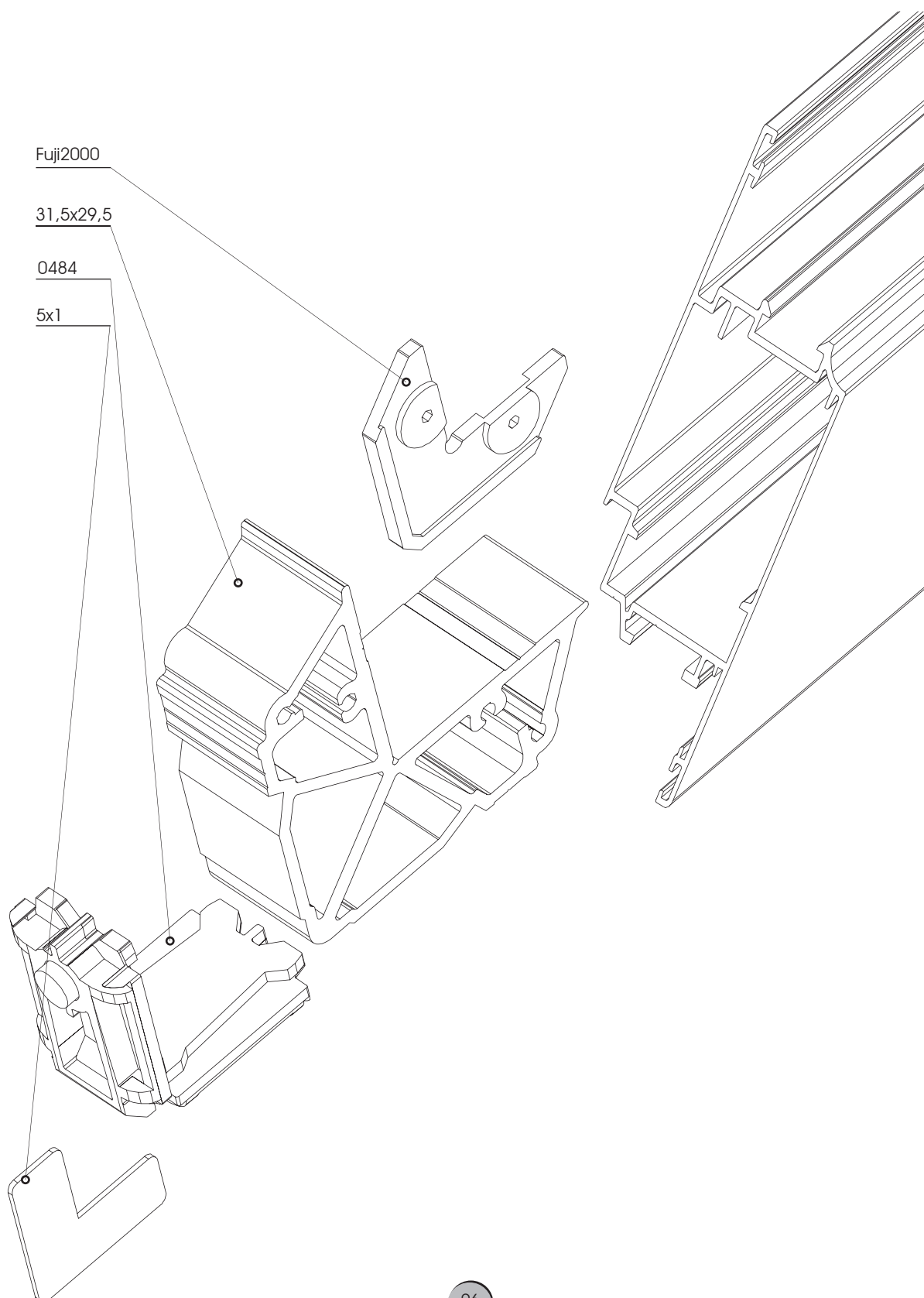

3D DETAILS

PRESS PUTTING AND ALIGNMENT ANGLES FOR BIG FRAME

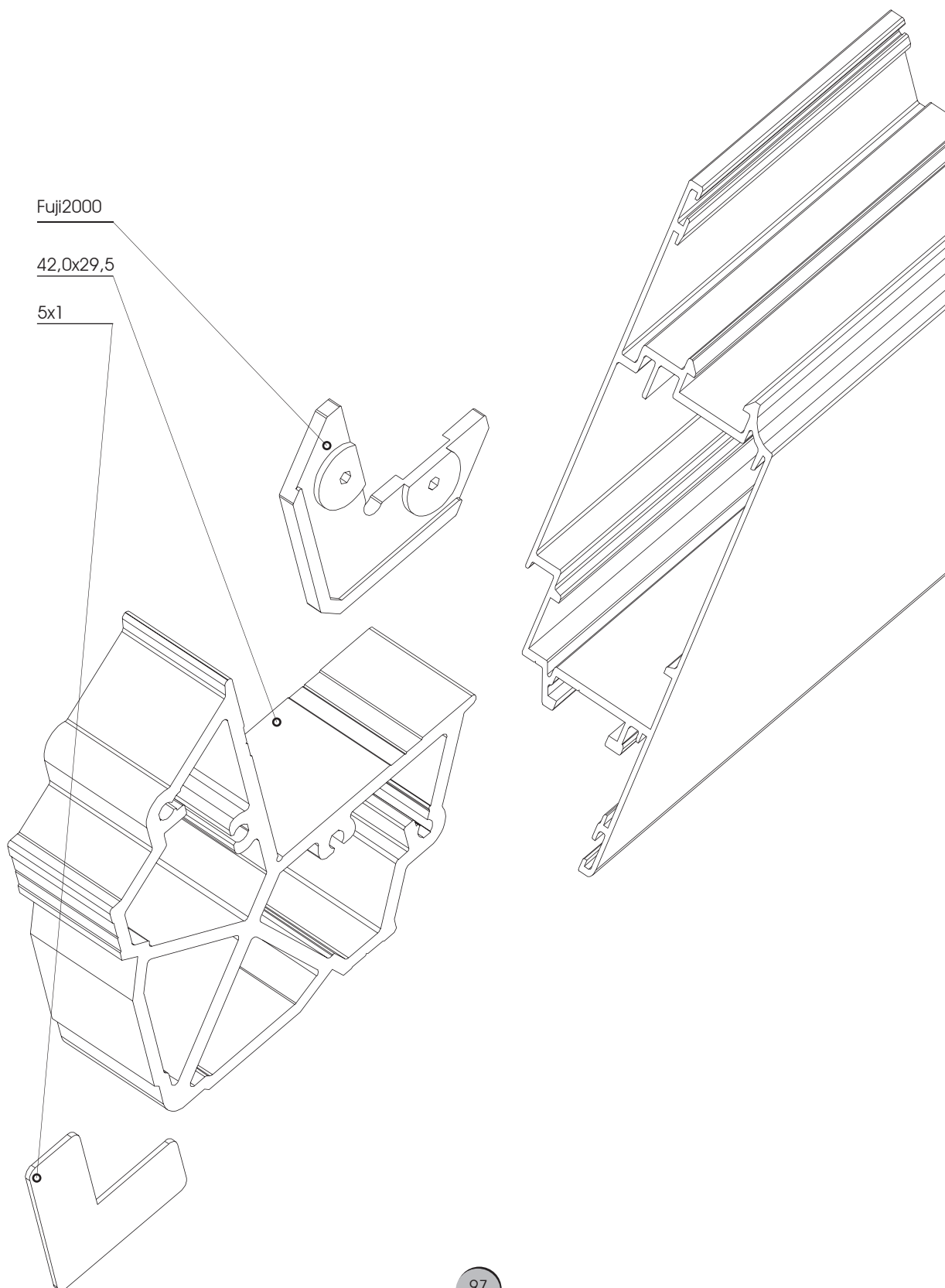

3D DETAILS

HANDLE FOR WINDOW

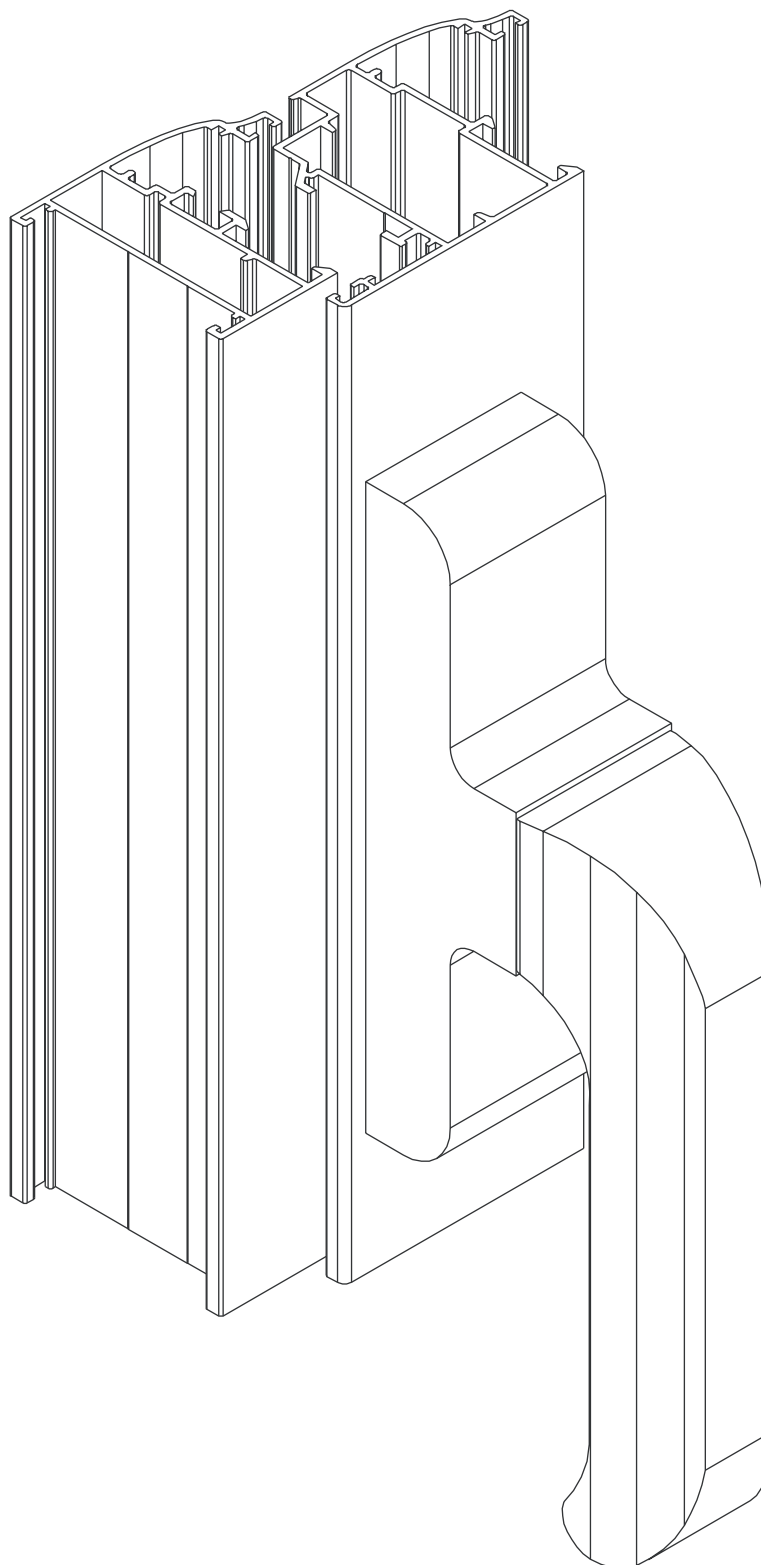

3D DETAILS

LATCH FOR WINDOW

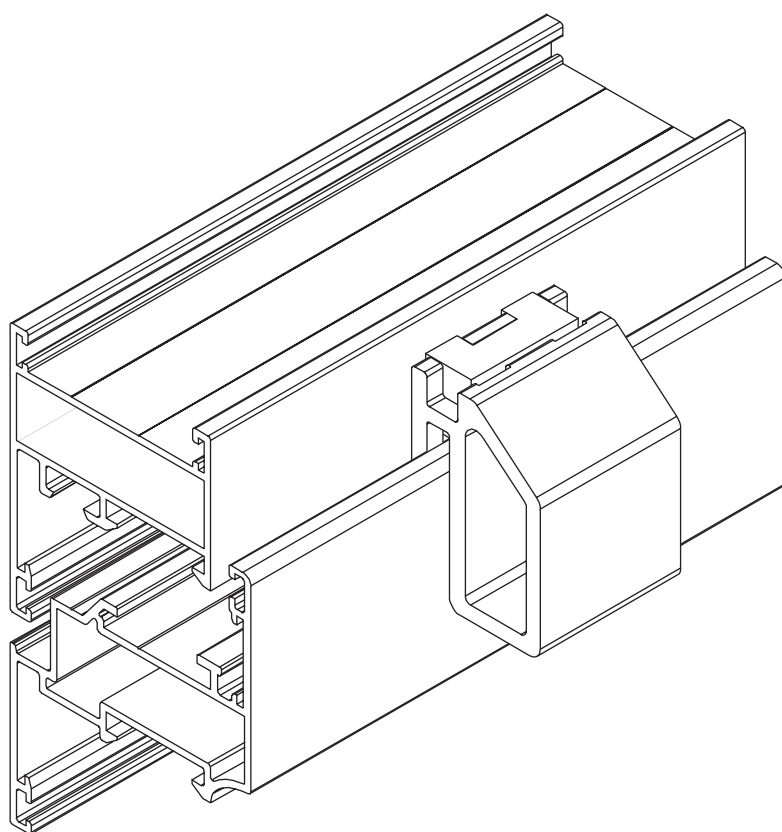

3D DETAILS

HINGES - "EURO-CAMERA"

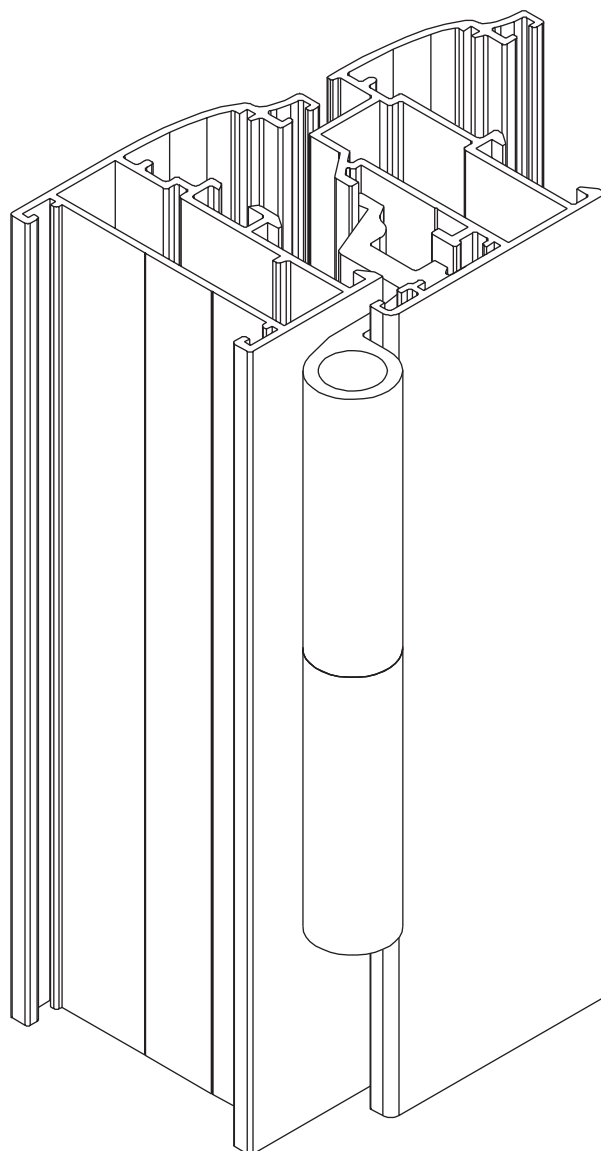

3D DETAILS

MILL FOR MILLING OF DETAILS

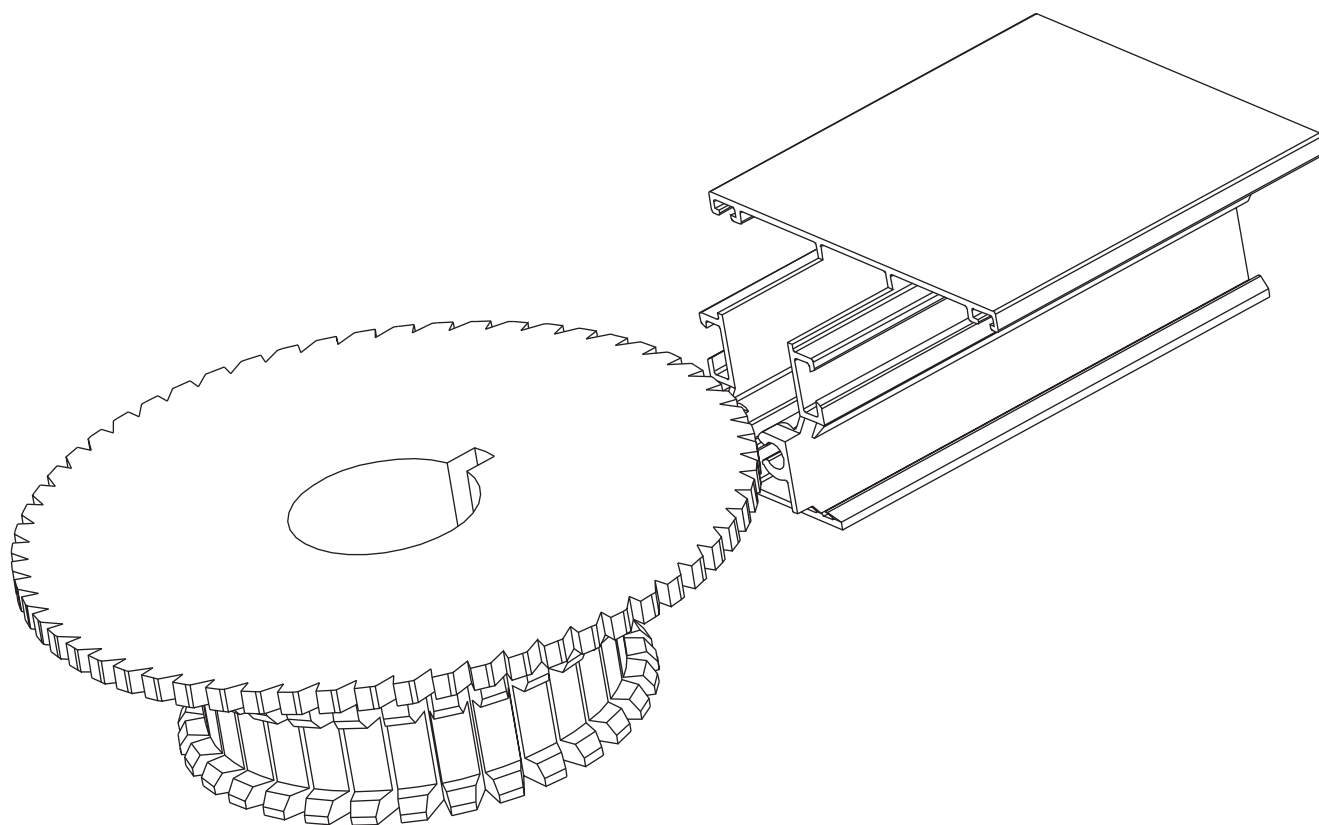

3D DETAILS

PLASTIC DREINAGE CAPS

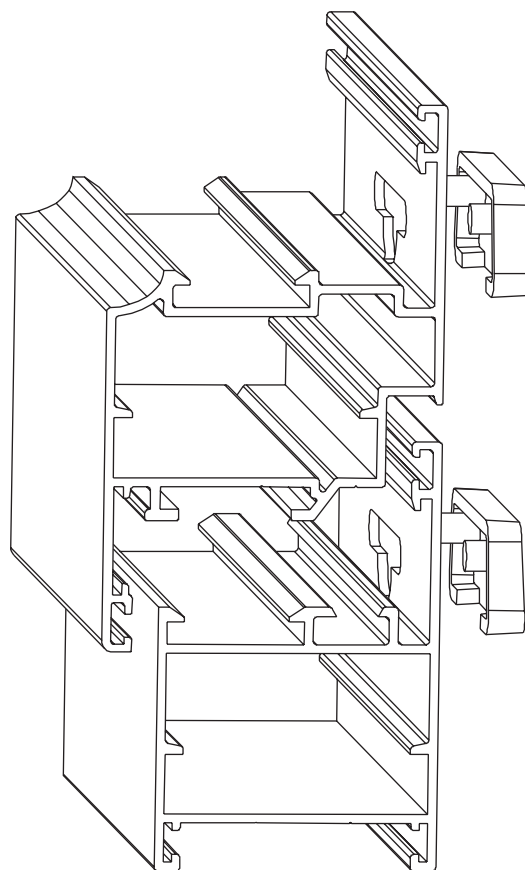

Scheme of drainage canals

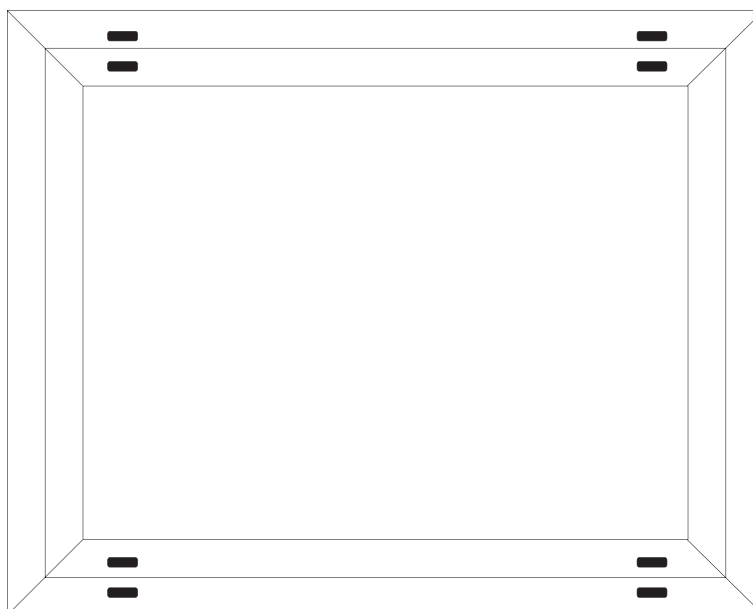

3D DETAILS

CAP FOR ADDITION ON TWO-WING OPPENING

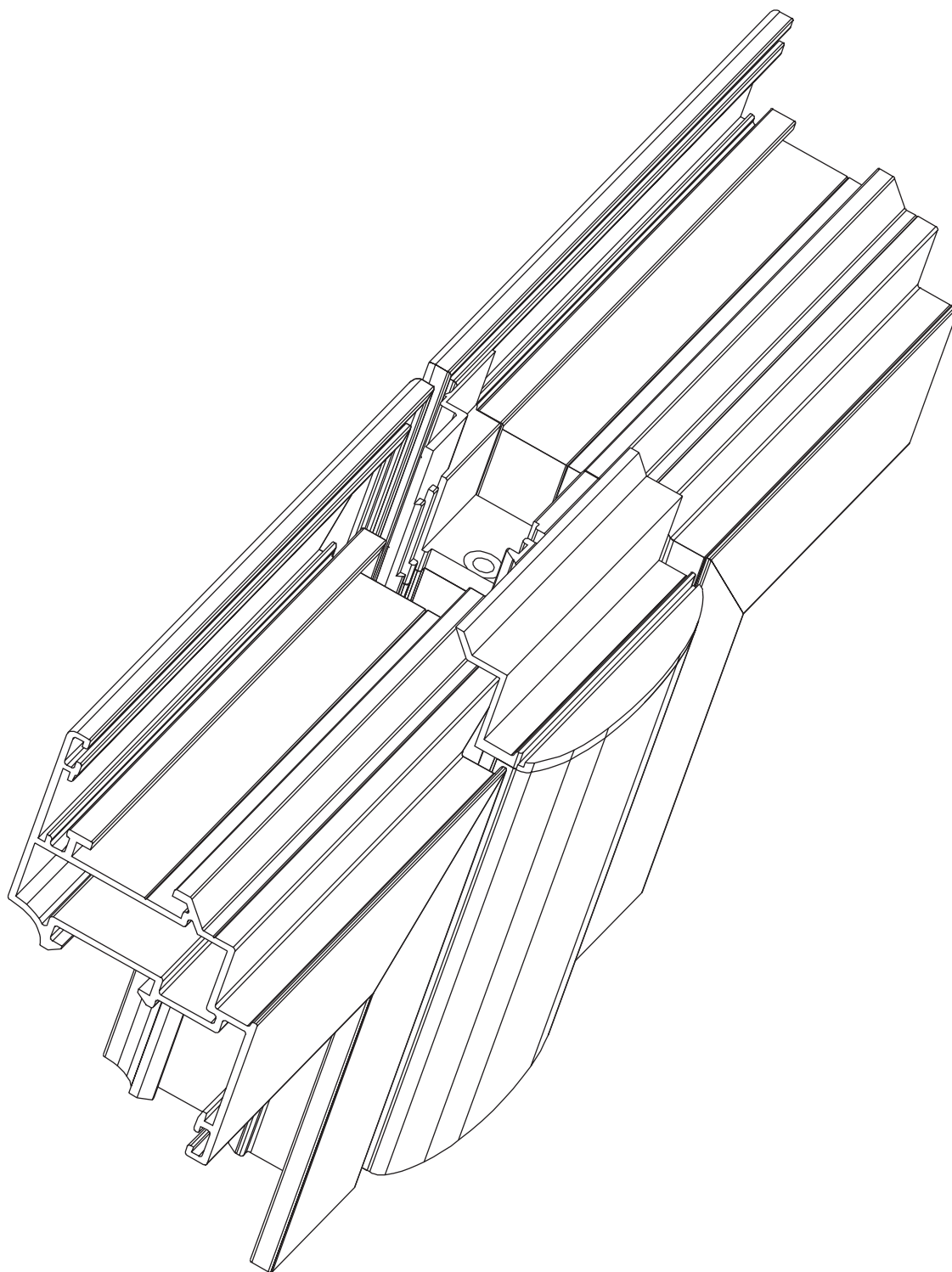

3D DETAILS

HINGES FOR TWO-SIDE OPENING

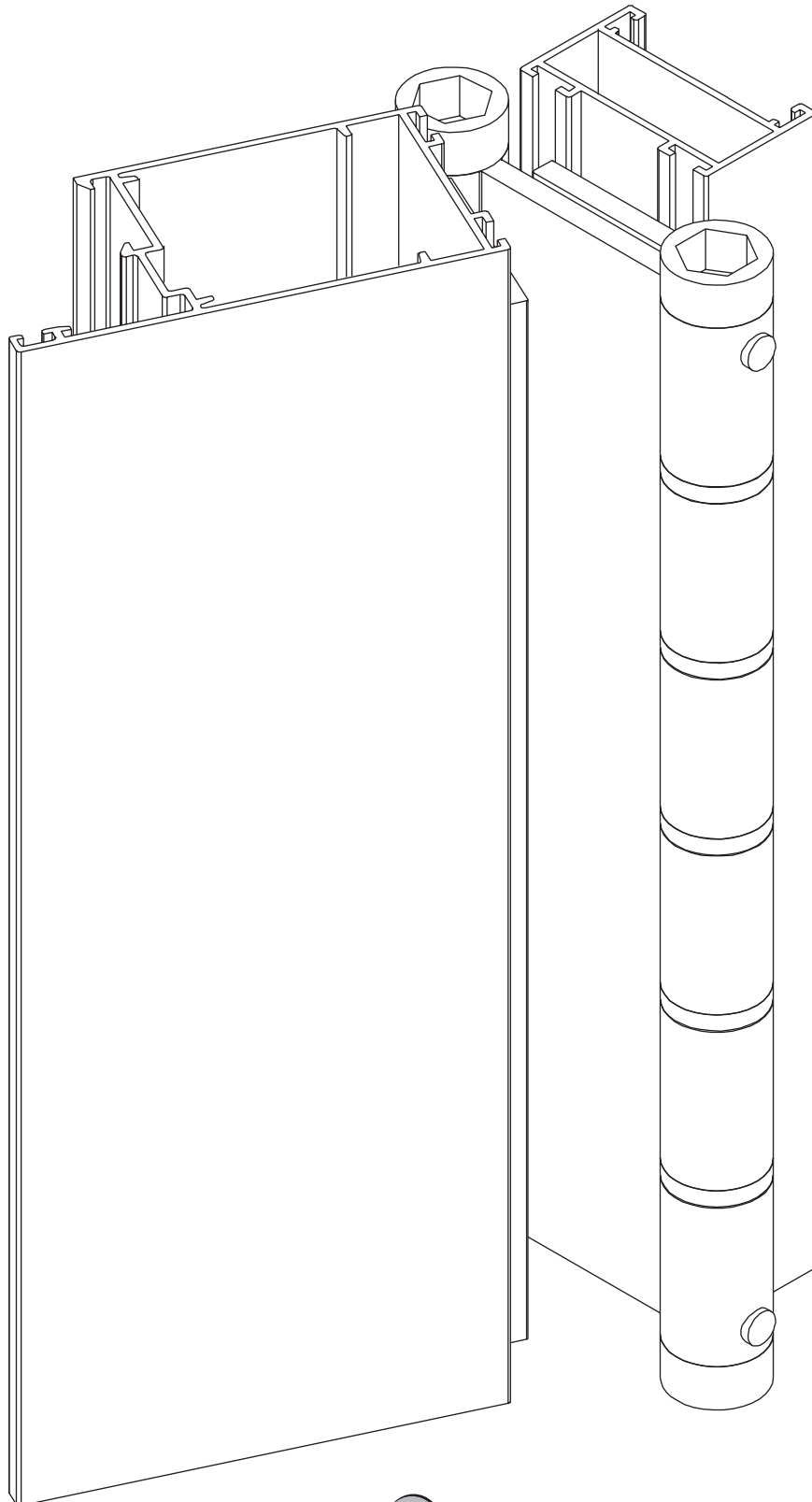

3D DETAILS

REVOLVING MECHANISM FOR OPPENING ON CENTRAL AXIS

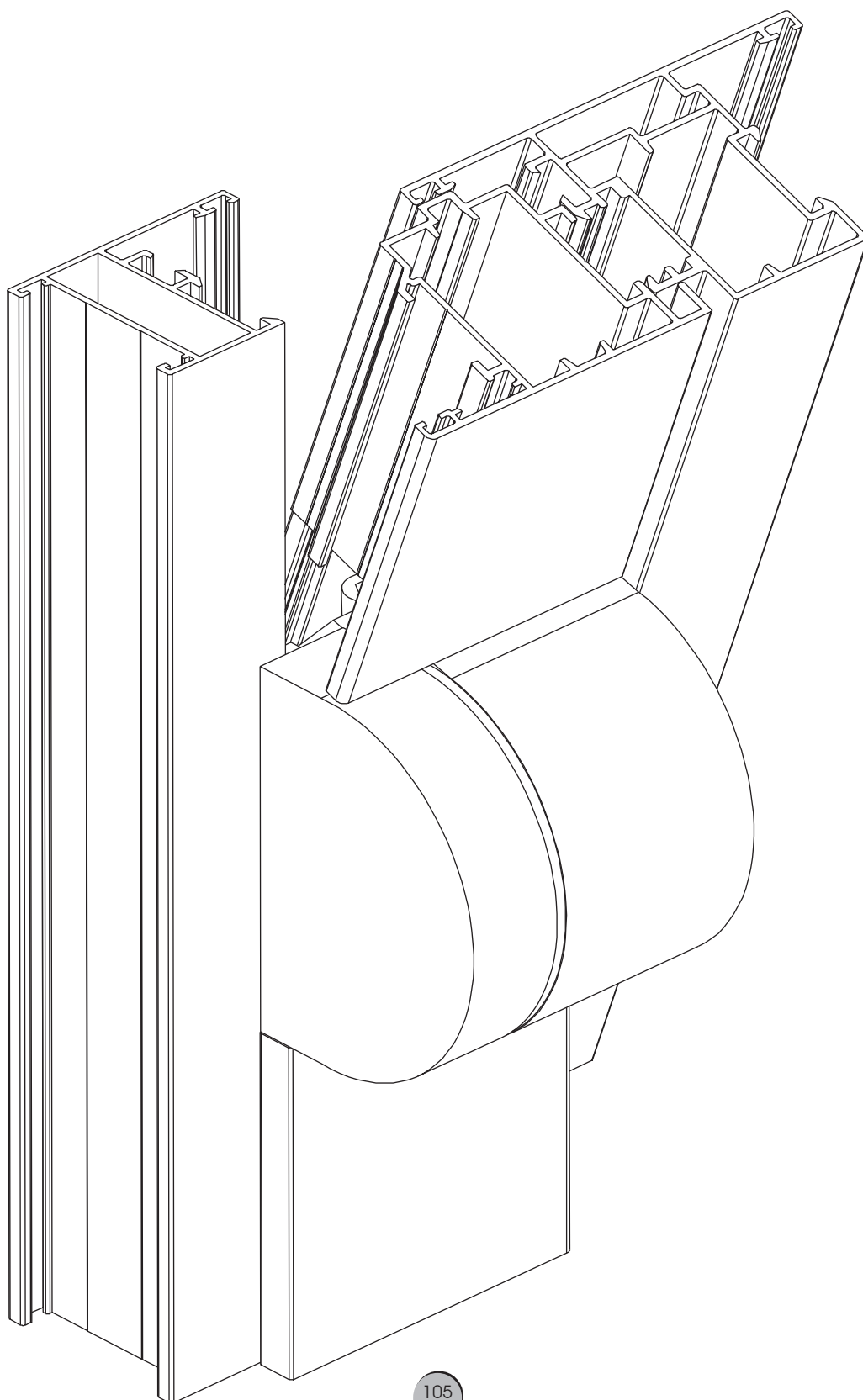

3D DETAILS

DOUBLE-FLATNESS MECHANISM - "EURO-CAMERA"

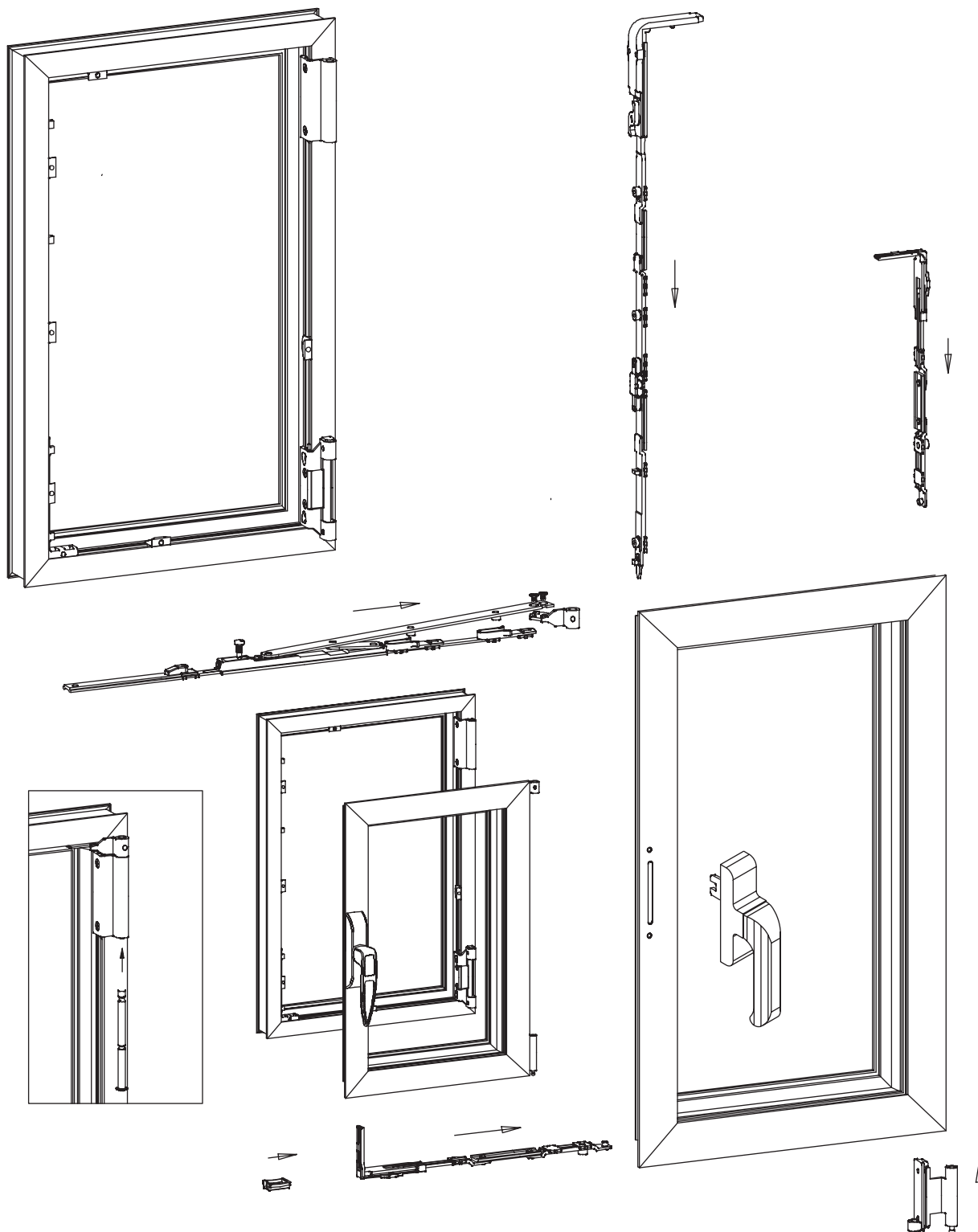

3D DETAILS

LOCK - 35mm, PATRON, OPPOSITER AND HANDLE FOR DOOR

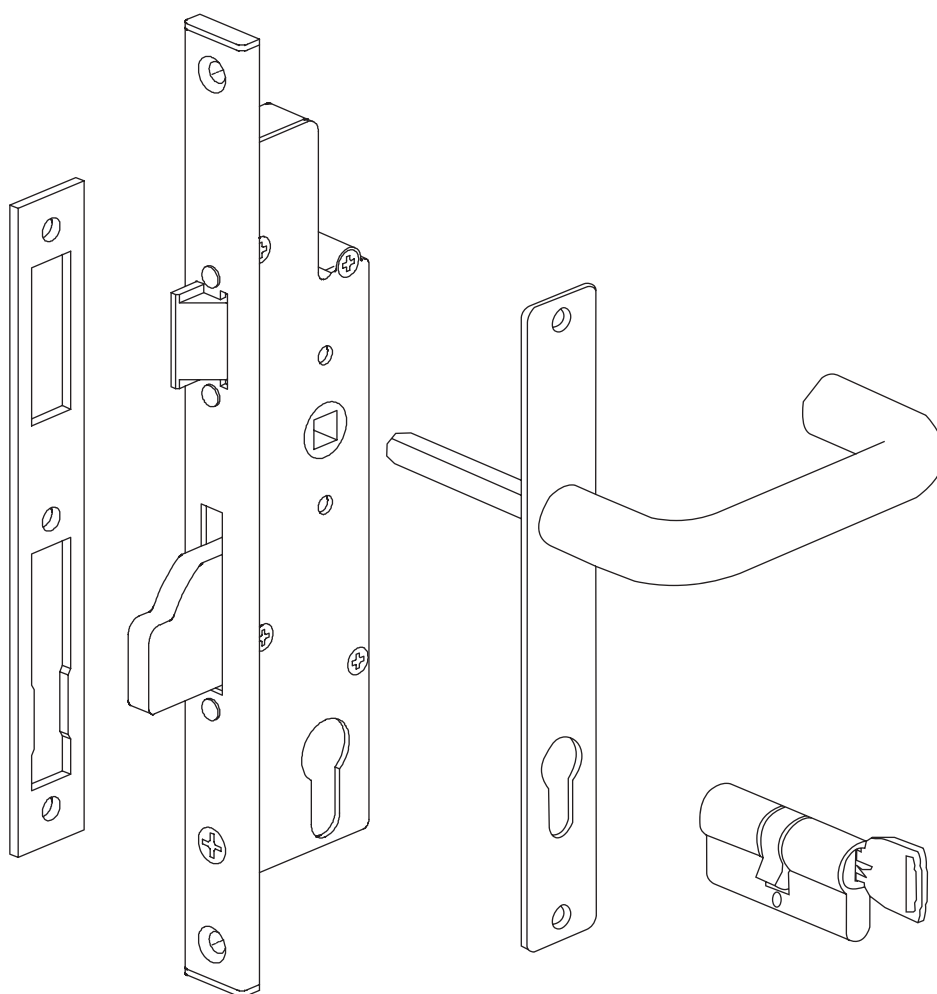

MECHANICAL PUTTING

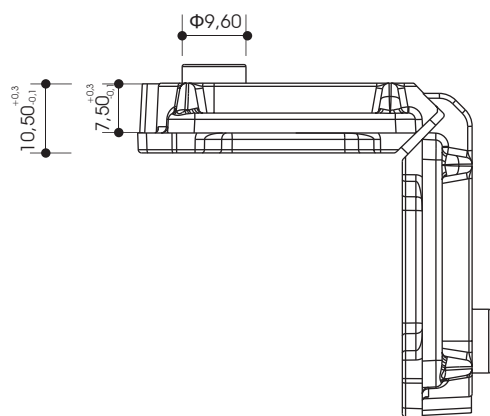

0484

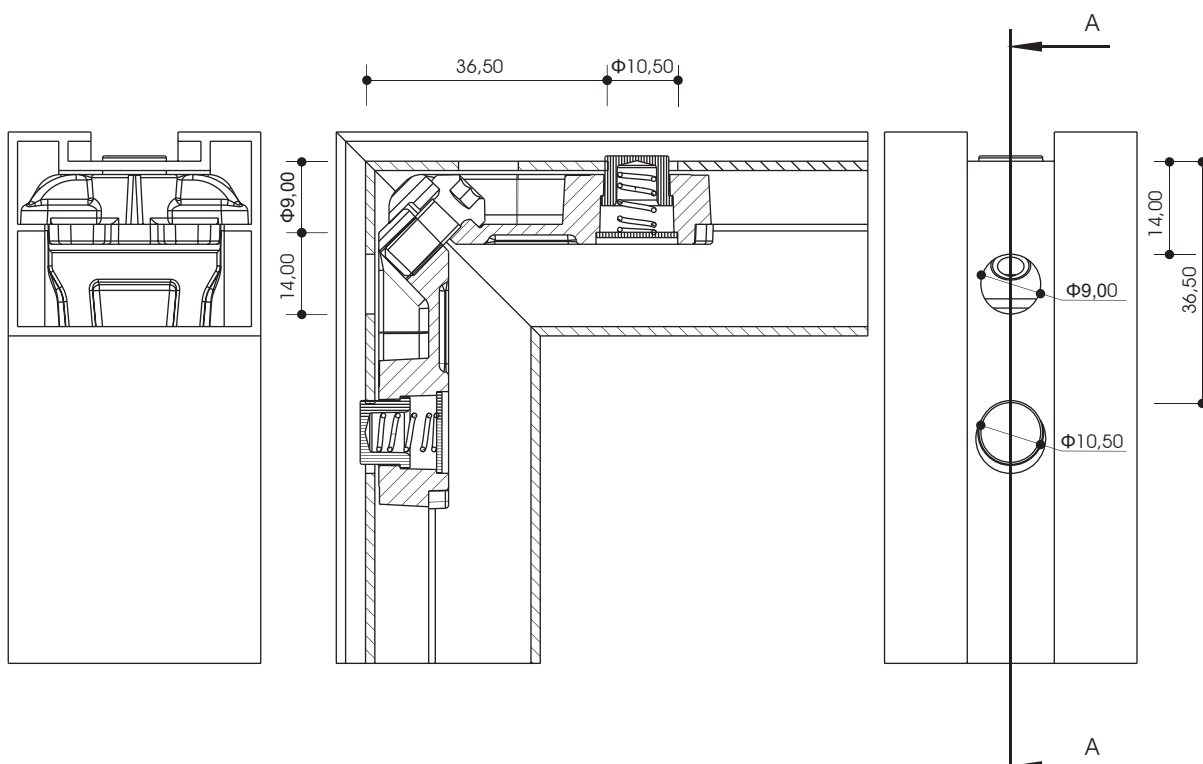
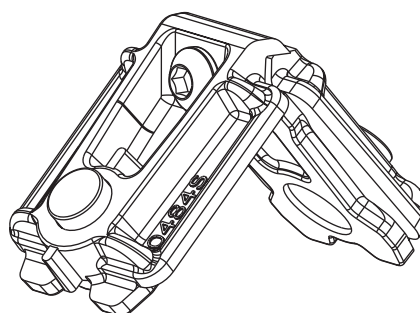
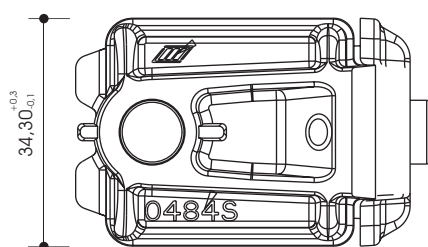
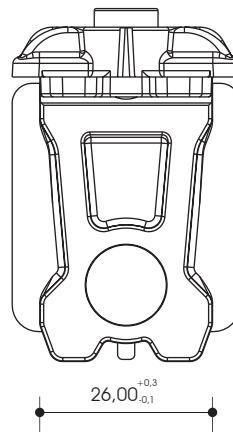

Recomendet for putting 0484S produced by "Monticelli"

PRESS PUTTINGS

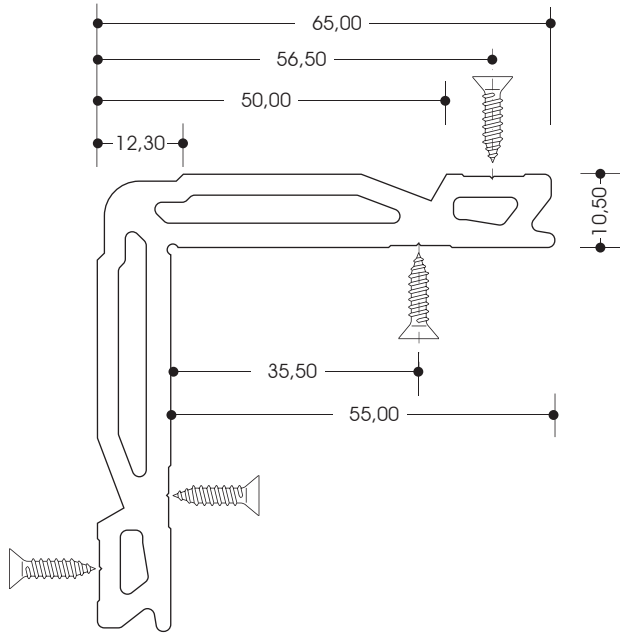

10,5x34,3

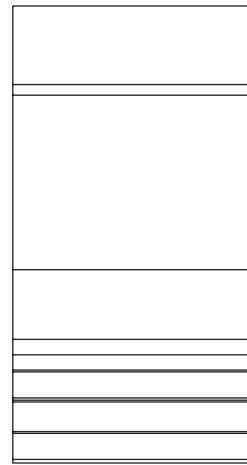

34,30

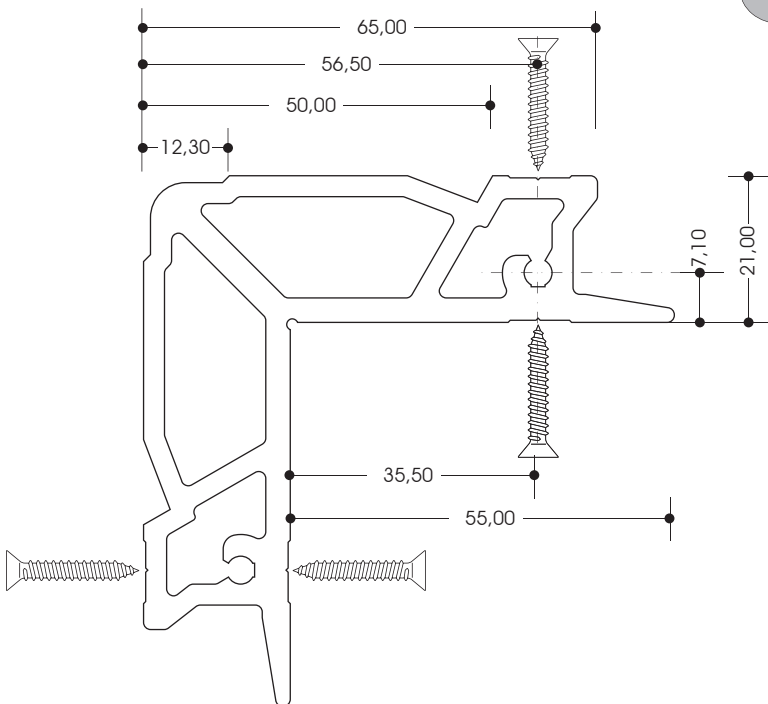

21,0x34,3

21,0x29,5

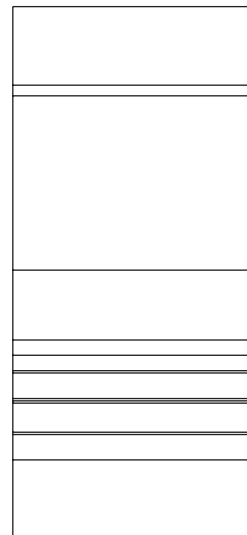

34,30

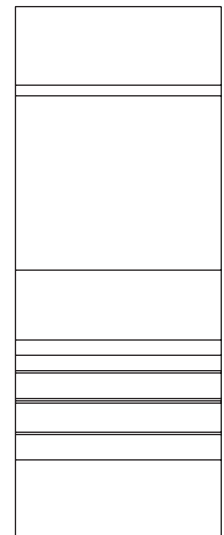

29,50

PRESS PUTTINGS

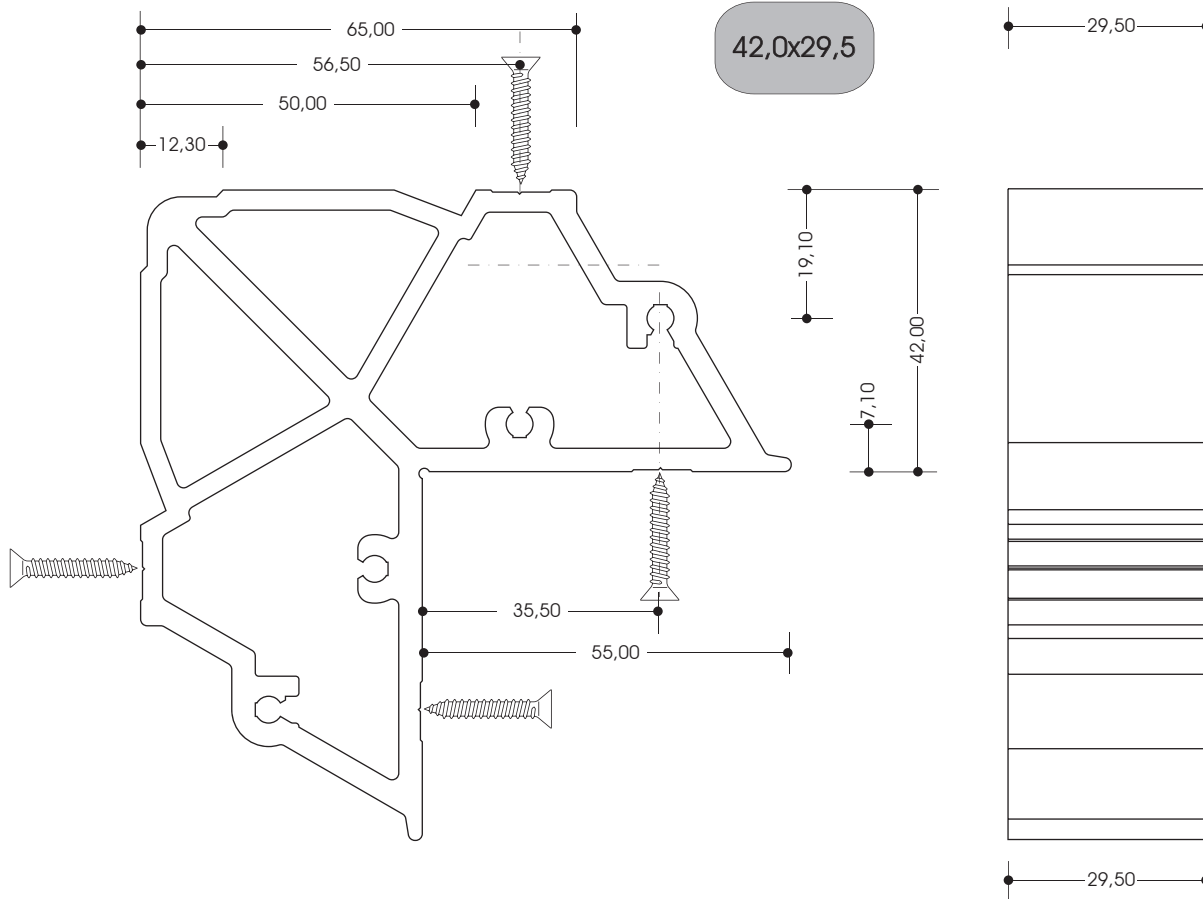
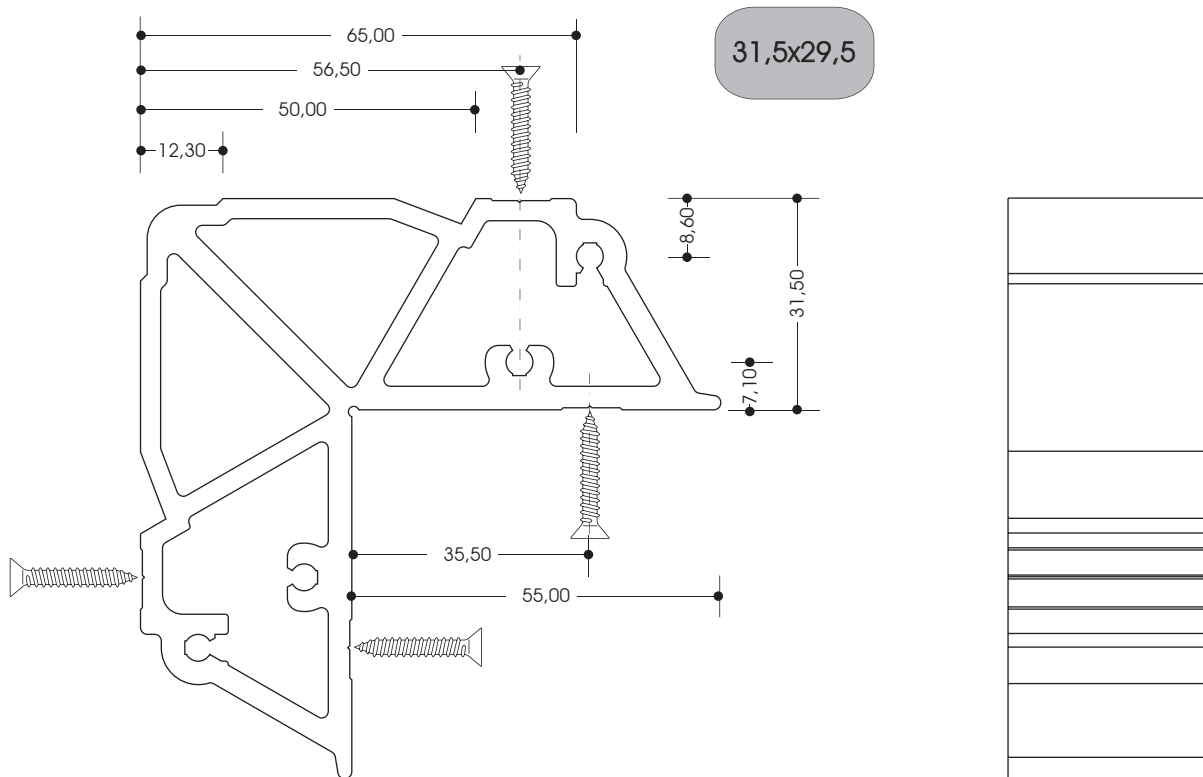

ALIGNMENT ANGLES

Fuji2000

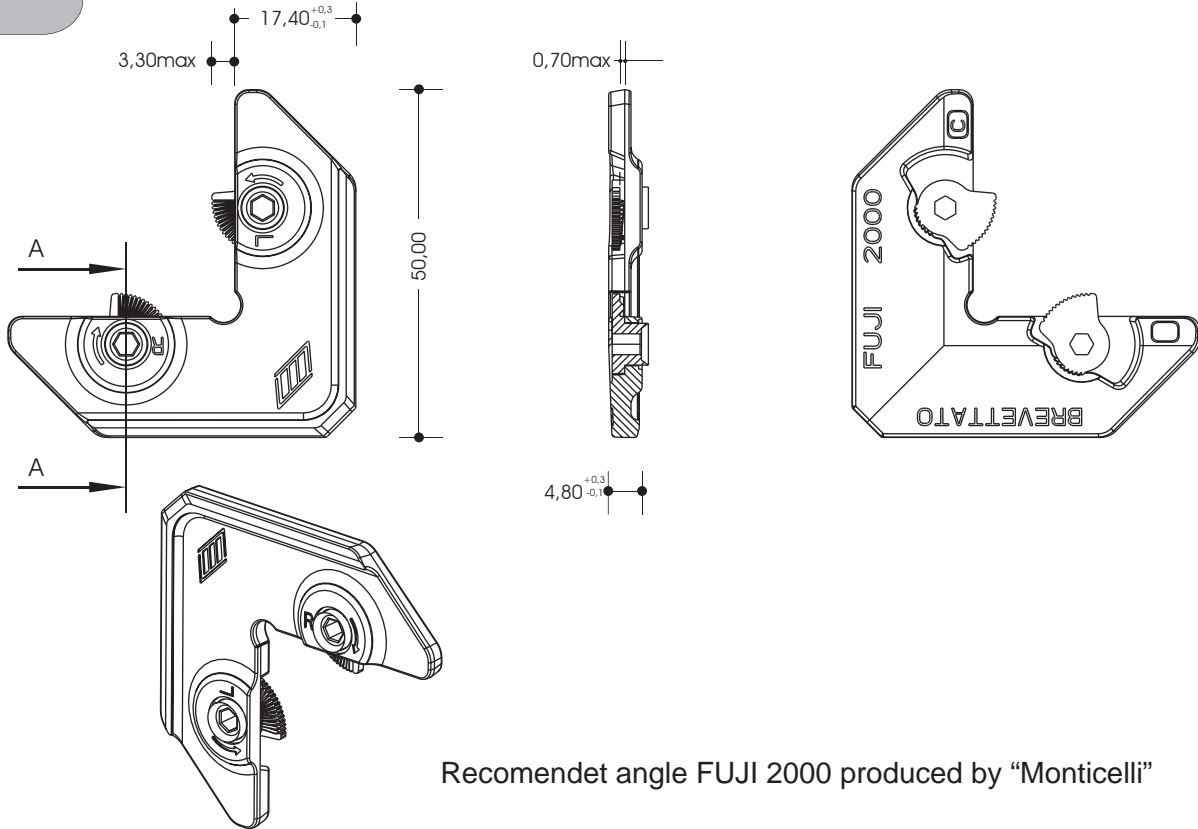

Recomendet angle FUJI 2000 produced by "Monticelli"

5x1

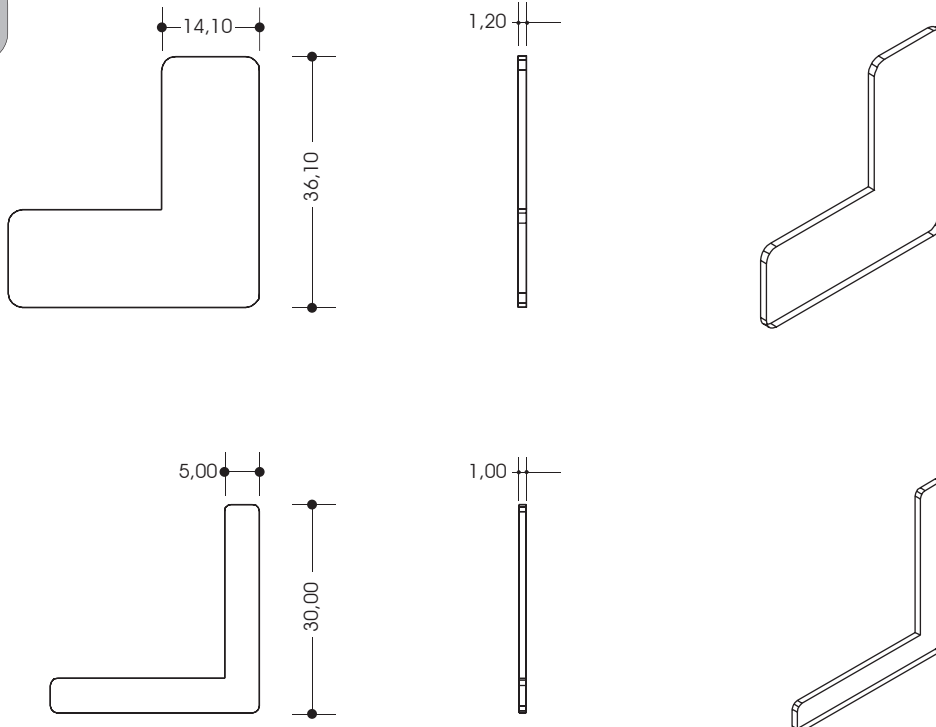

CONGEST GASKETS

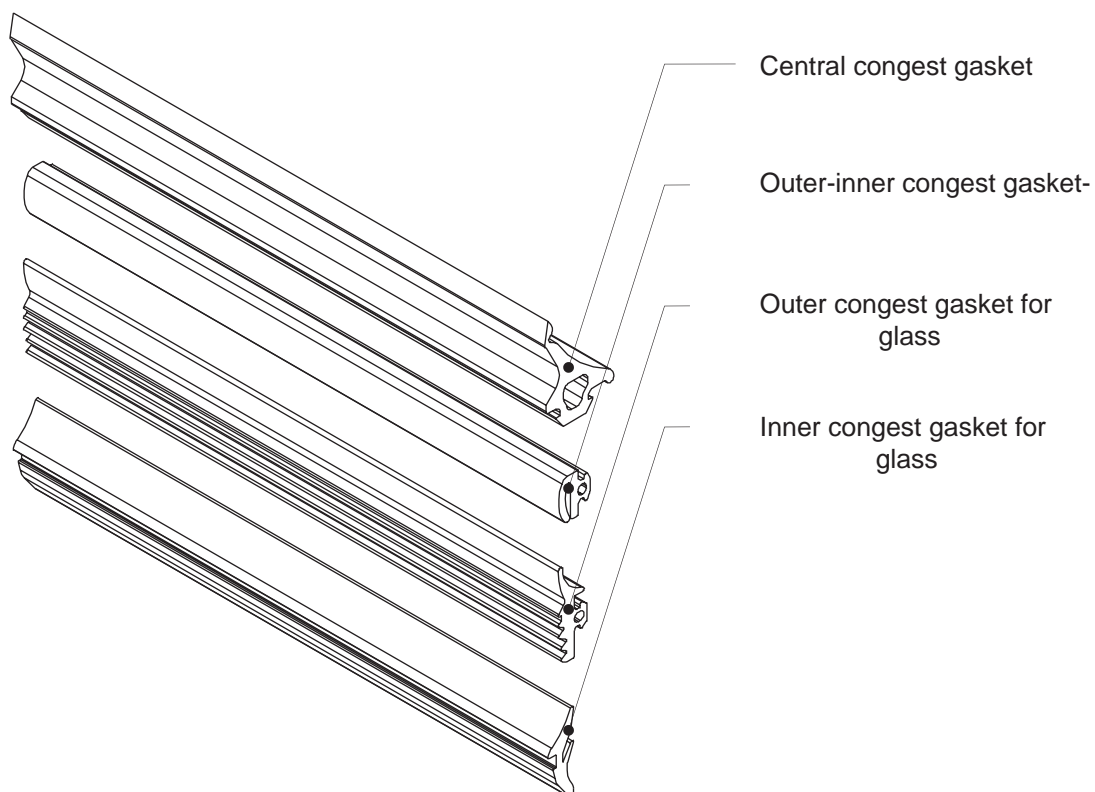

THERMAL ANALYSIS

U - factor for system 375 ~ 5,47-5,53 ($\text{W/m}^2\text{-K}$)

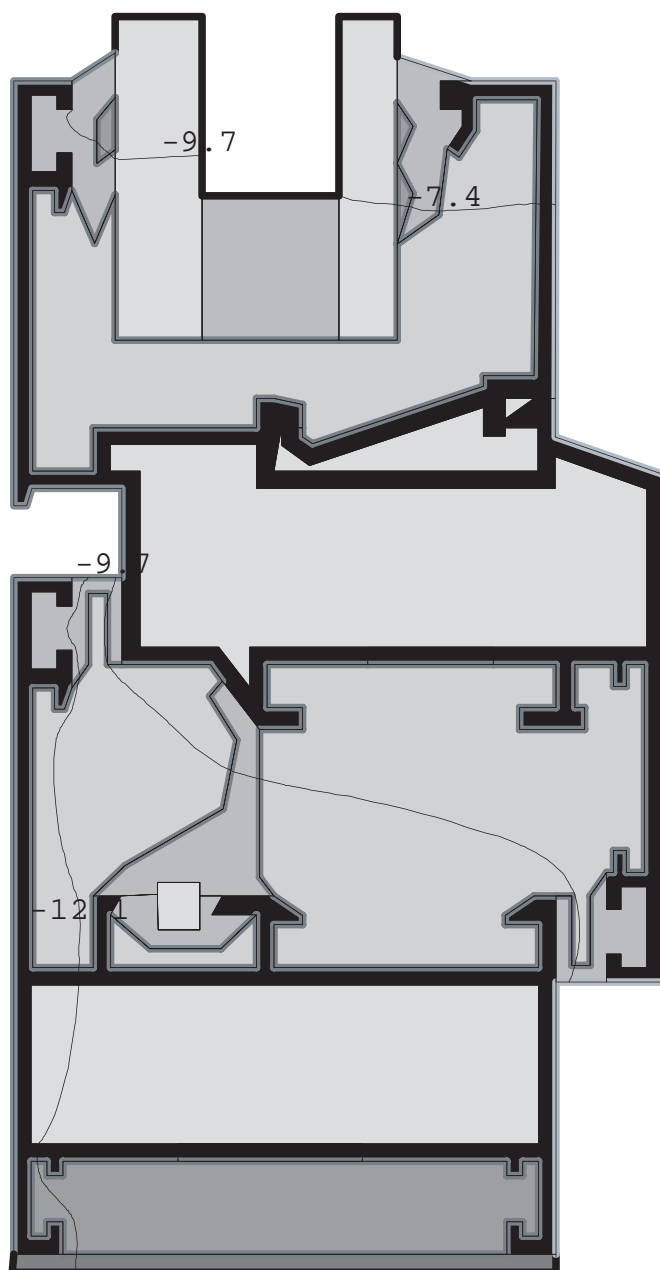

NOTES

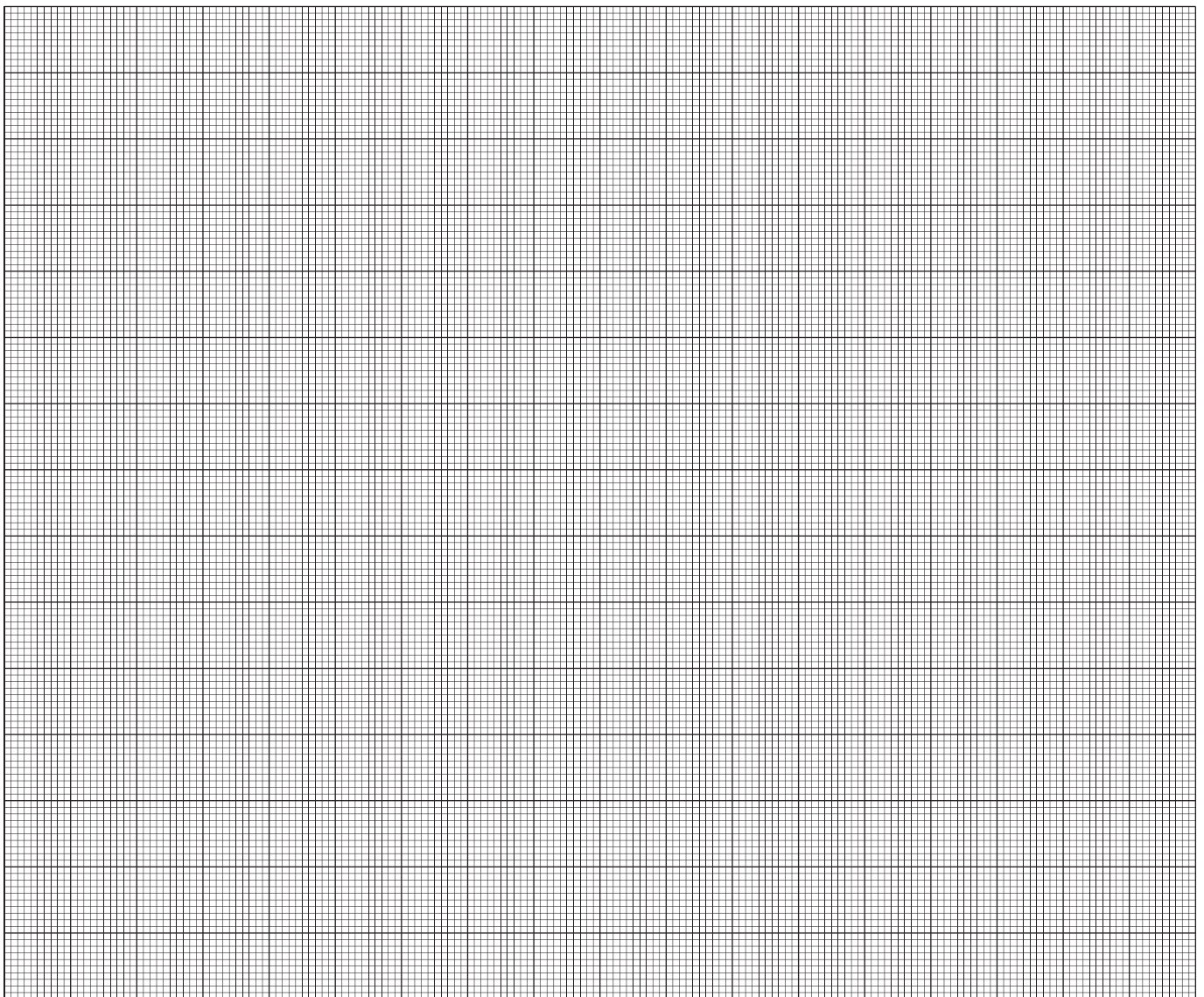

NOTES

